

# A Method for Determining Sensitivity to Penicillin and Streptomycin<sup>1</sup>

ROBERT E. HOYT and MILTON GJELHAUG LEVINE

*The Institute of Experimental Medicine,  
College of Medical Evangelists,  
Los Angeles, California*

The sensitivity of a microorganism to penicillin or streptomycin is an important consideration in determining the choice of a chemotherapeutic agent. Furthermore, the development of resistance during the course of therapy may make it advisable to modify dosage or to change drugs. The imperative need for this information has led to the development of a number of methods which can be used to measure sensitivity. These follow the general pattern of making a series of dilutions of the drug in some nutrient vehicle and then inoculating the medium with a culture of the organism being tested. Sensitivity is shown by a failure to grow in one or more of the dilutions. Existing methods are cumbersome and require the use of a sterile technique. Since a pure culture of the organism being examined is needed, testing may be delayed for several days.

To overcome these objections we have incorporated penicillin and streptomycin into compressed tablets 7/32 inch in diameter and weighing 60 mg. each. The tablet base found

Oxford units, and streptomycin tablets containing 1.0, 0.1, and 0.01 mg., respectively. Susceptibility of the organism to the drug is shown by a clear zone around the tablet (Fig. 1) which has a diameter proportional to the amount of drug contained.

The use of the tablets is very simple. An agar plate is streaked heavily with the organism being tested, and the tablets are dropped into position with forceps. The plates are incubated after inversion and are read when growth of the organism is sufficiently advanced to disclose susceptibility or resistance. Any type of solid media can be used as the base, since the results can be read by reflected light. We do not regard the precise measurement of the inhibition zone as being important, since its only value is the suggestion it may give as to therapeutic dosage. We have made no effort to sterilize the tablets before use. The growth of contaminants around the tablet is uncommon and, in any event, does not interfere with the observation. A control tablet containing only the ingredients of the granulation was run routinely for a while, but since there has never been any inhibition around it, we have discontinued this practice.

An important advantage which this method offers is the speed with which results may be obtained. Material such as sputum, exudates, and infected body fluids can be tested directly without preliminary subculture, since, even if contaminating bacteria are present, the various sensitivities can be observed.

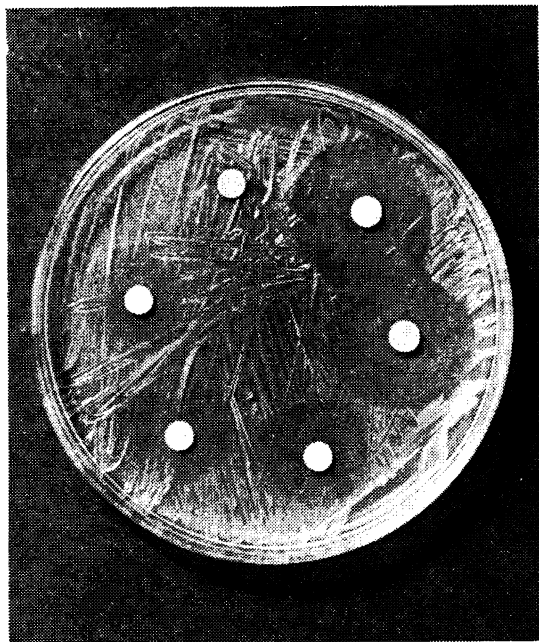

FIG. 1. Sensitivity of *Staphylococcus aureus* to penicillin and streptomycin. From the top, reading clockwise, the tablets contain 1.0, 0.5, 0.1 Oxford units of penicillin, 1.0, 0.1, 0.01 mg. of streptomycin.

to be most satisfactory contains dicalcium phosphate, starch, and gum acacia. The granulation is dried and passed through a fine screen, after which the calculated amount of the dry antibiotic agent is added and mixed thoroughly. To obtain an indication of the relative sensitivity of the organism, tablets containing varying amounts of drug were prepared. We have used penicillin tablets containing approximately 1.0, 0.5, and 0.1

<sup>1</sup> This work was aided by a grant from Boyle and Company, Los Angeles.

## Sea Water Systems at Marine Laboratories

G. E. MACGINITIE

*William G. Kerckhoff Marine Laboratory,  
California Institute of Technology, Corona Del Mar*

Since many salt water systems are being installed or remodeled throughout the world, a few suggestions concerning installation and materials should be timely.

The selection of metals to be used in such a system depends on their toxicity to animals and how rapidly they go into solution or combination with salt water ions to form toxic substances. Also, there is great variation in the amount of impurities carried by different metals. For example, generally speaking, cast iron from our West Coast is made mainly from scrap and carries a much greater percentage of impurities than does the pure eastern cast iron. From our experience with different metals, lead, tin, and pure-grade cast iron are the only ones that we feel safe in using where contamination must be held at a minimum, and even cast iron should not be left long in contact with salt water. Some metals having particularly bad lethal effects on larval forms are copper, zinc, and aluminum. Therefore, no brass or bronze fittings should be used in the salt water system where the water is expected to be used for experimental embryology. Monel metal, Inconel metal, etc. contain copper; stainless steel is also undesirable. Dishes made of such metals could not possibly be used safely for the culture of larvae, and this is our test for their safe use in any part of a salt water system. I therefore recommend that they not be used.

In purchasing metals such as lead, tin, or cast iron for use in a salt water system, pure grade should be specified and, if possible, tested out as containers for culturing larvae—for example, those of sea urchins. If a dish made of the metal

being considered can be used safely for culturing larvae over a period of two weeks, it can be used safely in the salt water system. It should be thoroughly washed before using. Such tests, of course, include a change of pure sea water every 12 hours, and the sea water should be passed through a nontoxic filter and come in contact only with clean glassware. Pure sea water should be obtained, even at a considerable distance at sea if there is any doubt as to harbor or shore contamination. This sea water should be filtered immediately and then may be kept in clean carboys for a long period of time. Such tests should be carried on at uniform temperatures equal to, or slightly below, that of the open ocean water in the vicinity of the laboratory.

An efficient salt water system at a marine laboratory is the nucleus upon which the activity of the laboratory depends, and too much care cannot be exercised in its efficient operation. One is justified in looking with suspicion upon experiments performed where impure salt water is used.

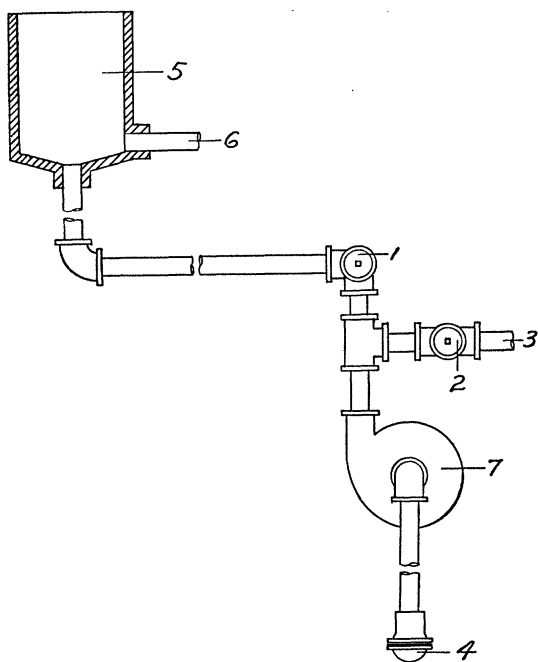

FIG. 1. Diagram of a salt water system: 1 and 2, cast iron stopcock valves; 3, drain pipe; 4, foot valve; 5, storage tank; 6, lead pipe to aquariums; 7, pump.

There are several fundamentals which should be carefully considered:

- (1) The laboratory should be located near an available source of clean sea water.
- (2) The pipe from the source of salt water should be of the proper material and should be as short as possible.
- (3) Arrangements should be made for flushing this pipe before pumping more water into the storage tank (Fig. 1).
- (4) The storage tank should hold sufficient water for about  $1\frac{1}{2}$  days. Even if the tank is larger, only enough water to last for that length of time should be pumped in each day.
- (5) The lowest level in the storage tank should be 10 feet or more higher than the aquariums.

(6) Lead pipe and rubber stopcocks should be used from the storage tank to the aquariums.

(7) Hot water should be used to flush the pipes from the aquariums to the storage tank.

(8) The storage tank should be properly constructed of non-lethal materials.

None of these requirements increases the cost of installation or operation of the system; in fact, the cost is decreased. Exclusive of the work of one man for 70 days, the system at the Kerckhoff Marine Laboratory cost \$958 in 1933. The sea water at the aquarium tables is as pure as the outside ocean water and is never more than  $1^{\circ}\text{C}$ . higher than the outside water. This system supplies two large laboratories, two smaller laboratories, a large aquarium, and a large live tank for storing animals.

A further discussion of the fundamentals listed above follows:

(1) Too many marine laboratories are built from an architectural standpoint rather than for a utilitarian purpose. If a marine laboratory is to function as such, it must be close to ocean water.

(2) Pure cast iron pipe should be used from the source of sea water to the storage tank. Lead-lined pipe is preferable if the salt water line to the storage tank is more than 300 or 400 feet long. This pipe should enter the *bottom* of the storage tank. The pump may be lined with stainless steel or with rubber. At this Laboratory a good cast iron pump has lasted 15 years and is still operating efficiently. It is advisable to have everything connected with the intake, pump, valves, and discharge into the storage tank of pure cast iron, for then there is no danger of electrolysis.

We use 3-inch intake from ocean to pump and  $2\frac{1}{2}$ -inch pipe from pump to storage tank. Three to 5 h.p. is sufficient for such a pump for heads of 40-70 feet. If a larger pump is used, 5 or more h.p. is necessary, depending on the size. A pump running continuously can be used, but is not to be recommended. If the pump should lose its prime and the water remain off for a few hours, months of labor may be lost as a result of death to experimental animals. If a continuous pumping supply of water is used, a duplicate pump and motor are a necessity. Also, some type of stand pipe with overflow to maintain constant pressure is desirable, although regulation of a sort can be effected by the use of a valve or valves. Neither gate nor globe valves should be used here or in any other part of the system. Cast iron stopcock valves are much more efficient and last years longer. Any pump manufacturer will furnish engineering advice free.

Many types of alarm may be used with the system. We use a  $\frac{3}{4}$ -inch overflow pipe coming out of the storage tank at just below full level, the pressure from the overflow tripping an alarm switch. Such a switch could be used on a float in the storage tank or in a stand pipe. A bucket-like trap that would fill and by its weight close a valve and also set off an alarm would be simple to make.

(3) Flushing may be illustrated by Fig. 1. By first opening valve 2 and then valve 1, water is allowed to flush the pipe from the storage tank to the drain (3). By closing valve 1 and starting the pump, the pipe from the foot valve through the pump is flushed out through the drain. By opening valve 1 and closing valve 2 with the pump running, the water being pumped is directed to the storage tank. All valves should be opened or closed easily to avoid water hammer. Either a good

foot valve should be installed at the point of intake and changed at low tide every two months or a short, flexible, rubber pressure hose should be used so that a change can be made at any stage of tide. It is necessary to have two foot valves so that one may be used while the other is being cleaned.

(4) One of the greatest mistakes made in salt water systems is the use of too large a storage tank. Salt water rots on standing, and the resulting chemical and pH changes are lethal, particularly to larval forms. If practically all of the stored water is used daily, the aquariums will remain sweet and the living material will flourish. If the storage tank is not too large, and if the pipe is flushed before pumping, the water will remain pure even though it is necessary to use a rather long cast iron pipe from the source of salt water to the storage tank.

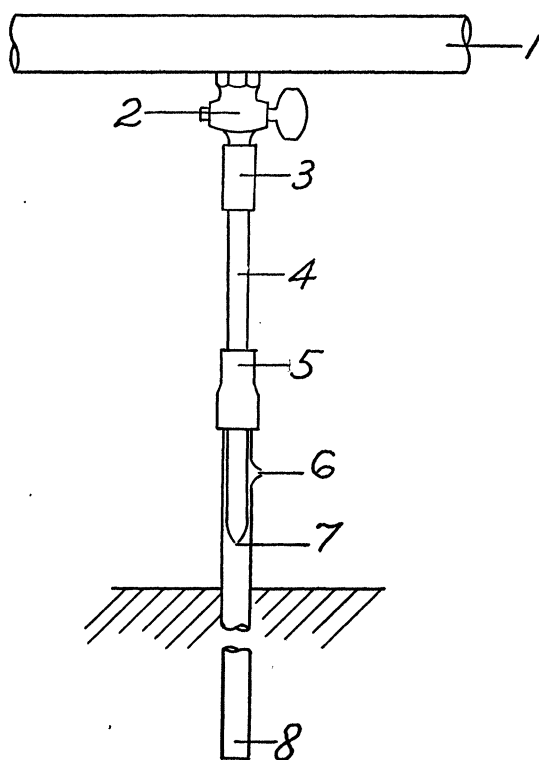

FIG. 2. Aerator for aquariums: 1, lead pipe over aquariums; 2, rubber stopcock; 3, rubber tubing connector; 4, glass tubing; 5, rubber tubing connector; 6, vent hole; 7, jet; 8, end of glass tubing near bottom of aquarium.

Organic material may be removed with filters, thus preventing some decay with its resultant ill effects, but these are expensive to install and keep up and are unnecessary if the above precautions are observed. Filters hold organic material which putrefies, and the products of decomposition wash through and contaminate the system.

Only slightly more salt water than will be used in the next 24 hours, more or less, should be pumped into the storage tank. Considering the location of most laboratories, that is, within a bay, water should be pumped just before or at high tide.

(5) Ten feet of head will provide ample force for aeration within the aquariums. After years of trial with many types of aeration devices, we use the rather simple setup shown in Fig. 2.

(6) *Thick-walled* lead pipe is most suitable, and less expensive in the long run, for conveying the sea water from the storage tank to the aquariums. Burning connections onto lead pipe can be done only by an expert workman and makes thin-walled pipe cost more than thick-walled pipe. This pipe need never be more than 2 inches in diameter; pipes to the separate aquarium tables, not more than  $\frac{3}{4}$  inch in diameter. The largest pipe in our laboratory is  $1\frac{1}{2}$  inch. Carrying capacity varies as the square of the diameter; therefore, a 2-inch pipe will carry nearly twice as much as a  $1\frac{1}{2}$ -inch pipe (all inside diameters).

Joints in the lead pipe are made by using bolt flanges and belling the lead over the sides to be joined together. Thus, when the flange bolts are tightened, lead comes against lead, and throughout the entire system from storage tank to aquarium tables, nothing but lead comes in contact with the sea water.

Thus far, most of the plastic pipe that we have experimented with has proved unsatisfactory for use with salt water. Some types seem to work fairly well after they have soaked out for a week or more, but the fact that they need soaking out is proof that, for some time, at least, they cannot be considered ideal. All trials with ordinary plastic garden hose have shown it also to be unsatisfactory. Some types we have tried quickly killed hardy marine animals after the pipe had been immersed in salt water for a week. We are now testing different plastics to determine if any are suitable for use in marine laboratories.

One-fourth inch hard-rubber outlet cocks, threaded with  $\frac{3}{8}$ -inch pipe thread, are best over the aquariums. These are easily installed. A nail set is driven into the lead pipe, the opening thus made being enlarged with a punch of the proper diameter for threading. This method builds a lip within the pipe which prevents the jet opening (Fig. 2) from plugging up with any bit of debris which may come in when the storage tank is filled.

(7) The better the system, the more growth, such as mussels, oysters, barnacles, etc., there will be within the lead distributing pipes. This cannot be killed with cold fresh water, because the animals close and remain so until sea water again comes in. Heat, however, will kill them quickly, especially if they are young. We connect a hose from the hot-water line in the laboratory to the outer end of each pipe over the aquariums and run water (90°C.) back through the pipe to the storage tank. This is done after draining the tank, so the hot fresh water drains to the outside. This flushing should be done at least once a month, preferably more frequently.

(8) When building the storage tank it is very important to be sure that its floor slopes from all sides to the combination drain and filling opening (Fig. 1).

A cement tank mopped inside with hot asphalt makes an excellent storage tank. The cement should be thoroughly dry before applying the asphalt, and after mopping it can be made to bond tighter to the cement by careful application of a blowtorch. Reinforcing should be kept well to the outside of the tank wall, for if sea water ever comes in contact with the reinforcing iron, rust will creep along it, necessitating a new tank.