

# Deep Sea Instrument Capsule

An unmanned system records pressure, temperature, and currents near the sea floor on digital tape.

Frank E. Snodgrass

Self-contained instrument capsules are dropped to the sea floor from a surface ship, where they remain for a period of several days to several months. The ship can return to port while data is accumulated by computer-compatible, magnetic tape recorders within the capsule. When the ship returns, the instrument capsules are recalled to the surface by acoustical commands transmitted from the ship. Upon command, the capsule releases its ballast by means of a solenoid release or an exploding bolt, and then ascends to the surface by its own buoyancy. Once on the surface, its radio beacons and flashing lights are activated to provide homing signals for the final recovery.

The capsule is adaptable to a variety of experiments. At present, deep sea tides are being measured by recording the fluctuating pressure on the deep sea floor to an accuracy of a millimeter. Temperature changes, measured to a few millionths of a degree, and water currents in the range of 0.1 to 10 centimeters per second are also recorded. Several dozen drops to depths of 4 kilometers have been made, which yield 1-month records of pressure, temperature, and current speed and direction taken at intervals of 2 minutes.

An international program for the study of deep sea tides, under the auspices of the International Association of Physical Sciences of the Ocean, has been proposed (1). Instruments for measuring tides at great depth have been successfully used off the coast of France (2) and in the Pacific (3).

The deep sea instrument capsule (Fig. 1) is assembled in two parts: (i) the buoyant aluminum spheres (Fig. 2) which house the digital data recorders, the electronics for the acoustical system, the radio beacons, and the

flashing lights, and (ii) the instrument frame (Fig. 3) that supports the transducers, the release mechanism, tilt and direction meter, and a battery for the radio beacon. The spheres and instrument frame are connected by a 15-meter cable. A ballast of automobile batteries holds the equipment firmly on the bottom while supplying power to the system. The spheres, because of their buoyancy, are tethered upward at the end of the electrical cable where they cause no interference with measurements made near the bottom. When the release device is activated, the connection to the battery ballast is broken, which allows the spheres and the instrument frame to rise to the surface while the batteries remain on the bottom. The capsule ascends at a speed of about 1 meter per second. All components are designed for safe operation at depths up to 5.3 kilometers.

The aluminum spheres (Alcoa) are 22 inches (56 cm) in internal diameter with a 1-inch (2.54-cm) wall and have a working pressure of 7800 pounds per square inch (530 atmospheres); the spheres provide 48 kilograms of buoyancy each. Of the 96 kilograms of buoyancy provided by two spheres, 20 kilograms is needed for metal frames, mechanical parts, and cable; 20 kilograms of net buoyancy is used to lift the capsule back to the surface, which leaves 56 kilograms for instrumental payload.

Work at sea has been simplified by a new oceanographic vessel *Ellen B. Scripps* designed to carry portable instrument laboratories. A special air-conditioned laboratory with railway-type tracks in the floor (which extend through large double doors and then across the ship's deck to the crane) simplifies handling of the 230-kilogram capsule. The electronic circuits can be made ready in the clean, dry environment of the portable laboratory. When

tests and calibrations are completed, the capsule is filled with dry nitrogen and sealed while in the portable lab. In addition to equipment and spare parts for maintenance of the capsules, the portable laboratory contains a loran receiver, radio direction finders, acoustical transmitters, and receivers.

## Pressure Measurements

Tide measurements are made by sensing the bottom pressure with the Vibrotron pressure transducer (United Control Corporation). A tungsten filament about 1 centimeter in length is stretched in a magnetic field and encased in a dry atmosphere at very low pressure. One end of the wire is attached to a rigid frame with the other end attached to a diaphragm. Under pressure, the diaphragm deflects causing the tension of the wire and its natural frequency of vibration to decrease. With the wire connected in the feedback of an amplifier, a variable frequency oscillator is obtained whose frequency is a function of pressure. A Vibrotron pressure gauge with a range of about 7000 meters of water pressure [10,000 pounds per square inch (681 atmospheres)] has a sensitivity of  $-1.3$  hertz per meter of water pressure at typical ocean bottom depths. By conventional digital techniques the Vibrotron's frequency, when sampled for 2 minutes, is measured to an accuracy of  $6 \times 10^{-4}$  hertz, which provides a least count resolution of 0.8 millimeter.

There is always a question of the reliability of such high-resolution recordings. The quality of the recordings is best defined as the ratio of the instrumental noise energy at various frequencies to the energy of the signals to be recorded at these frequencies. To obtain this information, pressure gauges were capped to exclude external pressure signals, capsulated in a thick layer of insulating foam, and then buried 1.8 meters (6 feet) underground in a quiet temperature environment. The output of the pressure gauges was recorded with a resolution equivalent to the sea bottom measurements. Cross-spectral analyses of data from the two capped pressure transducers provide a measure of the coherent and incoherent (noise) spectral energy. The principal tides are typically 60 decibels above noise level in a month's record after correction for temperature.

The author is research engineer in the Institute of Geophysics and Planetary Physics, University of California, San Diego.

## Temperature Measurements

Temperature measurements with a resolution of  $10^{-3}$  °C are required for Vibrotron corrections to the nearest millimeter of equivalent water pressure. With the oceanographic temperature probe (Hewlett-Packard), measurements with a resolution of  $10^{-5}$  °C are readily obtained. The temperature probe (Fig. 4) provides a correction for the pressure transducer, and the data are of great interest in a general study of sea-floor conditions.

The Hewlett-Packard temperature probe consists of a cylindrical pressure case containing two solid-state crystal oscillators, a mixer circuit, and output amplifier. The crystals, one cut for high temperature sensitivity and the other cut for zero temperature coefficient, are used to obtain the temperature measurements. The difference frequency changes  $1000 \pm 5$  hertz/°C with zero output frequency occurring at  $-5$ °C. Measurements of the transducer frequency in cycles per 120 seconds produces records with a resolution of better than  $10^{-5}$  °C.

The crystal cut for zero temperature sensitivity is mounted within a pressure case, while the crystal cut for high temperature sensitivity is mounted at the end of a stainless steel coaxial tube (2.5 millimeters in diameter) in order to isolate it from the heat developed by the electronics. An underwater pressure connector provides a two-wire connection for a d-c power source and the a-c readout device.

As with the pressure measurements, the quality of the temperature measurement can be defined as the ratio of the signal level to the instrumental noise level. The instrumental noise spectrum was determined from the incoherent energy between two temperature probes buried underground for 1 month. Measured ocean temperature spectra are at least ten decibels above the measured laboratory noise spectra. At tidal frequency the energy is 40 decibels above noise level, even though the temperature is remarkably uniform.

## Current Measurements

A probe containing an indirectly heated thermistor, whose temperature depends upon the cooling of the water, was designed to measure ocean bottom currents (4). A threshold below that

normally achieved by mechanical devices, low power consumption, high reliability, and a frequency output compatible with the recording system were major design considerations.

The probe has a resistor and thermistor placed inside a copper fitting which is inserted in the center of an epoxy-filled Micarta tube (Fig. 5). Regulated voltage is applied to the resistor so that a fraction of a watt is dissipated in the copper insert. Depending upon the speed and direction of the water flow, the temperature of the copper element will rise a few degrees above ambient temperature. A threshold of 1 millimeter per second is established by the forced convective heat transfer caused by the water velocity, which becomes competitive with the

free, convective heat transfer. When the forced convection becomes dominant

$$(\Delta T)^{-1} \sim U^{1/2}$$

where  $\Delta T$  is the excess above ambient temperature and  $U$  is the water velocity.

Maximum cooling occurs when the water flow is in a plane perpendicular to the axis and is independent of direction in that plane. It is assumed that the flow is nearly horizontal. A pair of probes is mounted vertically, with one probe heated and one unheated to measure the magnitude of the current.

The temperature difference of two probes mounted horizontally at right angles provides good directional sensitivity while canceling the effect of ambient temperature. However, for a given temperature difference four directions are possible. The ambiguity is resolved by correlating the angles measured by two pairs of probes displaced  $135^\circ$  and by taking advantage of the asymmetry introduced in the directional response by the mounting post. Directional calibrations are sensitive to the speed of flow. Given the measurements from the three pairs of probes, the computer interpolates calibration data to determine the direction and magnitude of the flow.

Power for the current meters is obtained from the ballast batteries. The electronic system, mounted in a pressure case on the instrument frame, supplies regulated power to the probe heater and converts the resistance ratio of the probe pairs to pulse trains. The pulse frequency, which is linearly dependent on the temperature difference between the probes, is measured and recorded by the digital system in the capsules.

## Digital Recorder

The digital recording system (Fig. 6) (Datametrics Corporation, Van Nuys, California) is designed to accept five input signals simultaneously, measure either the mean frequency or mean period over a time interval adjustable from 1 to 1024 seconds, and record the data on 0.5-inch magnetic tape in standard IBM binary format. The recording also includes parity, record gaps, longitudinal check characters, and end-of-file indicators. With each data cycle a fixed character and a binary sample number are recorded for con-

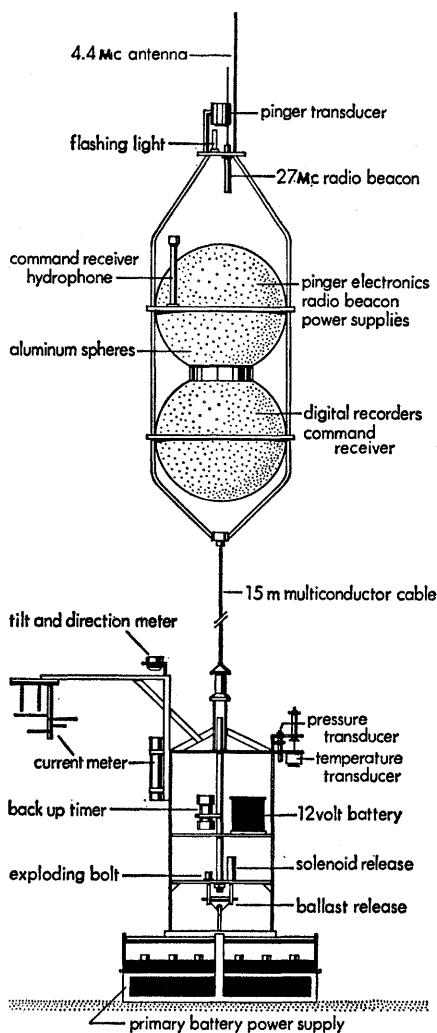

Fig. 1. Aluminum spheres which house electronic systems are tethered to the transducer frame by a 15-meter electric cable. The transducers, well removed from disturbances caused by the spheres, are rigidly attached to an automobile battery ballast. The battery ballast remains on the bottom when the capsule is recovered.

trol. Data tapes can be read directly by the computer.

Timing in the digital recorder is provided by a quartz crystal oscillator which operates at 131,072 hertz. After binary division, a 1-hertz signal is applied to a ten-bit binary counter with several ten-bit diode "and"-gates connected in parallel. The diode gates are mounted on a printed-circuit, plug-in card with solder terminals. For reliability, wired jumpers rather than switches seemed advisable for the capsules. By unplugging the card, solder jumpers can be installed between appropriate terminals to program the time between readings (repetition interval) and the time over which the readings are to be averaged (gate interval).

During the gate interval, signals from the five transducers are applied to the input of the binary data counters. The counters overflow many times; thus only the least significant bits are retained for recording on the data tape. The missing bits of the data numbers can be inferred from the transducer calibration and the approximately known environment.

At the end of each gate interval the data accumulated in the binary counters are scanned six bits at a time by a diode matrix which is equivalent to a 6-pole 16-position stepping switch. Sequencing pulses are obtained by decoding the time-base binary dividers. The 16 biocidal (six binary bits) characters are written at a rate of 32 char-

acters per second; thus 0.5 second is required to scan and record the data. Parity check bits recorded in the seventh track are generated separately as the data are scanned to complete the standard format.

After recording on tape, the measurement is held in the counters until 0.25 second before the next measurement is to occur. At that time all binary counters are reset to zero and the binary sample number counter is increased by one count. The 16-bit sample number provides a total capacity of just over 62,000 recordings, slightly greater than the capacity of the magnetic tape.

Five 16-bit diode coincidence gates wired across the sample number counter provide programming for several devices during the experiment. These include: (i) an acoustical pinger program, (ii) an "off" pulse for a ship-commanded pinger program, (iii) an "on-off" program for heater elements of the current meter (for purposes of a calibration), and (iv) two spare circuits for special purposes.

#### Tape Recorder

The principal features of the tape recorder (Type DSP340, Kennedy Corporation, Pasadena, California) are its computer-compatible, seven-track tape format and low power consumption. The tape transport which weighs

12 pounds is mounted on a panel [8.5 inches by 11 inches (21.6 cm by 28 cm)], has a 300-foot (91.4-meter) cartridge-loaded data tape, and is incremental in operation. A standard writing density of 200 characters per inch provides storage for 720,000 seven-bit characters. Using 16 characters for each data cycle, 45,000 recordings can be made of the five input transducers with time and identification characters included in each reading.

To be computer-compatible a "non return to zero" magnetization tape format is required. Thus the tape must be saturated in one of two polarities with the polarity reversed between bits when a "one" is written or left unchanged when a "zero" is written. The write amplifiers are therefore supplied with a magnetic-latching relay memory to retain the last character written. When the write pulse is received, an input circuit senses the data lines, reverses the polarity of relays in channels with a "one" input, and leaves the relays unchanged in all channels with a "zero" input. The write amplifiers then apply current to the recording heads according to the relay polarity and the tape is stepped 1/200 inch (0.013 centimeter). The relays are then properly set as "memory" for the next character.

Even though peak currents of 2 amperes are needed, the average power required by the tape recorder is kept small by reducing the duty cycle. In

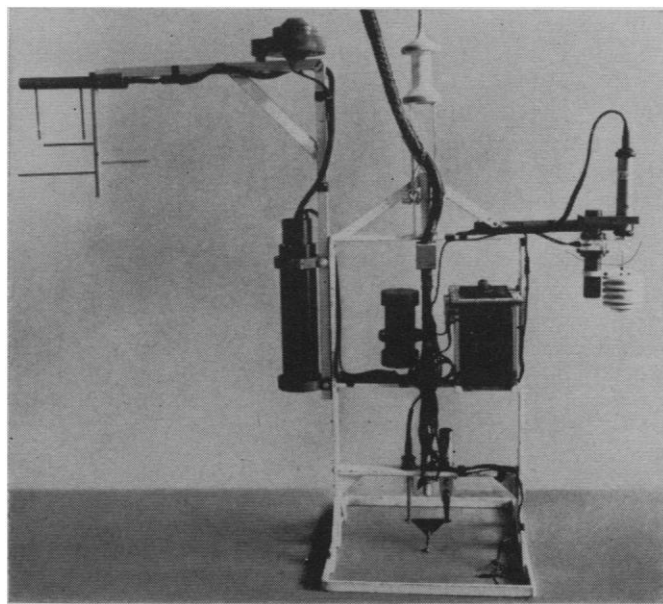
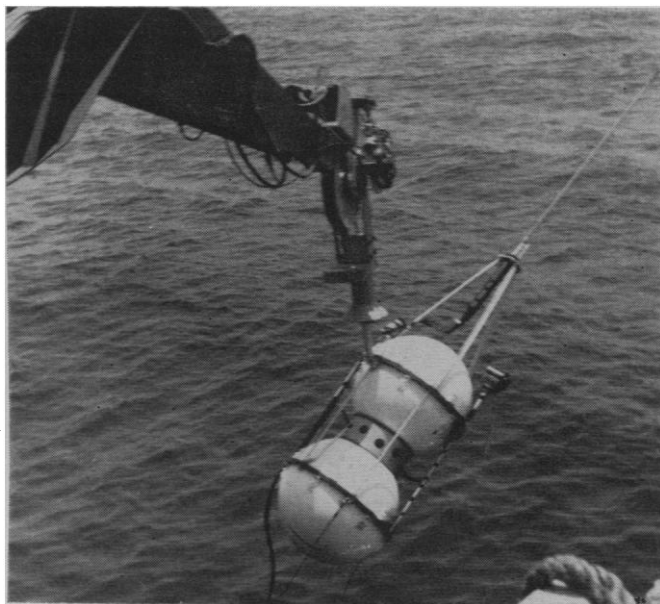

Fig. 2 (left). Instrument capsule is hoisted overboard for free fall to the sea floor. Fig. 3 (right). Instrument support frame with various components identified in Fig. 1. The ballast is attached by a bolt (0.375 inch in diameter) at the bottom of the frame. Electrical connections to batteries are made through connectors at base.

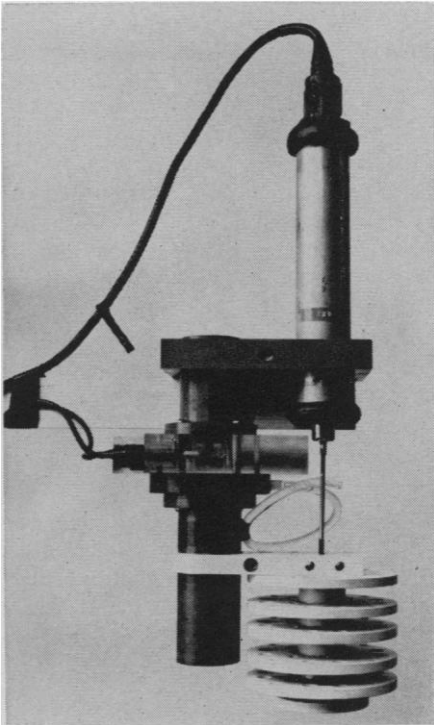

Fig. 4. The Vibrotron pressure transducer and Dymec temperature transducer are connected thermally by a metal clamping bar. Radiating fins on the temperature probe increase the thermal time constant for compatibility with the 2-minute data sampling rate.

the standby state only a "write command" sensing circuit which draws 0.2 milliamperes is energized. When a write pulse appears at the input, power is applied to all tape recorder circuits, current is applied to the recording heads, and the data tape is stepped. The power is then removed, which returns the recorder to the standby condition. The writing sequence can be repeated 50 times a second.

During each write sequence the 2-ampere peak current is required for about 10 milliseconds. The energy required to write a data tape of 720,000 characters is 48 watt-hours; the standby energy required for 1 month of operation is 1.7 watt-hours. The total writing and standby energy can be supplied by small batteries with a large capacitor connected in parallel to provide the peak currents. Normally, however, the tape recorder power is supplied by lead-acid batteries mounted in the ballast unit.

Take up and supply spools in the tape cartridge are rotated by d-c motors as required by the recorder. Cam-operated microswitches energize the motors to maintain two loops of tape be-

tween the spools and each side of the write heads. Approximately 1 inch (2.54 cm) of tape is taken from the tape loops each time one of the microswitches is closed. The motors, energized for about 0.5 second every 20 minutes, require a small amount of energy compared to that used to write the data tape.

### Reed Relays

To simplify performance at sea, provision has been made to operate the necessary "off-on" voltage switches, the tape recorder, and the initiating controls of the digital system with the capsule sealed. The controls include the digital system power "on" and "off," tape recorder power "on" and "off," tape recorder stepping circuits "on" and "off," tape gapping control, write "end of data file," reset time base to zero, and reset sample number to zero. The first three pairs of controls hold each circuit "on" or "off" until given the opposite command. The remaining four controls are activated only while being commanded.

The controls are operated by applying signals of an appropriate frequency to a pair of leads provided in the cable harness of the capsule. The frequency-sensitive reed relays in the capsule are selectively energized to activate transistor driver circuits. The driver circuits either provide logic level signals for the digital system and tape recorder control, or they operate magnetic latching relays for the three "on-off" controls.

A portable battery-powered oscillator with push-button switches provides the ten necessary signal frequencies. As each switch is pressed, the oscillator is turned "on" with the frequency adjusted to a preset value. When no switches are being pressed, a meter on the panel indicates which of the latching relays are energized. Capsule pinger signals are used to monitor gapping, zero sample number, and proper resetting of the time base.

### Acoustical System

Two-way acoustical communication (5) is maintained between the ship and the instrument capsule while the ship remains on station. Frequency-coded commands are transmitted from the ship to the capsule; time-cooled pinger

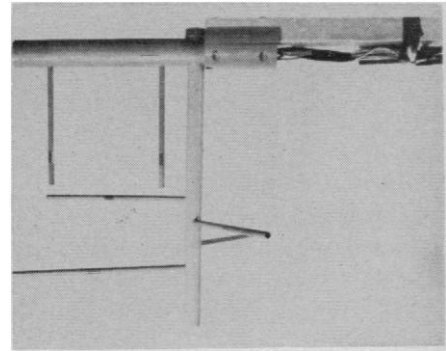

Fig. 5. The Caldwell water velocity probes. Copper fittings at the center of Micarta tubes contain an indirectly heated thermistor. The temperature of the copper element is dependent upon the cooling of water. The vertical pair of probes provides measurement of water speed parallel to the bottom. Two pairs of 90° horizontally mounted probes provide data on current direction.

pulses are transmitted from the capsule to the ship. No provision for the transmission of digital data from the capsule to the ship has been included in the design, but 15 pinger codes supply diagnostic information to describe the conditions of equipment in the capsule. Pinger pulses also serve as an acoustical homing beacon for the ship.

### Ship Commands

The most important ship command releases the ballast to allow the capsule to return to the surface by its own buoyancy. Release is accomplished by activating an electromechanical clamp or by firing an explosive bolt. Another command activates the acoustical pinger circuits that provide an instrument check. The input to the pinger is sequentially switched through eight test circuits and remains on each circuit for 0.5 minute. Transducer outputs and various power supply voltages are checked. The third command is used for special purposes; one such use involved an arm attached to the instrument frame. After the capsule had stabilized on the bottom for 1 day, the command was transmitted. Temperature and pressure gauges attached to a light-weight arm were released and allowed to fall to make measurements about 5 centimeters above the bottom. Other proposed uses include operation of cameras and dye markers, water samplers, and the exchange of transducers.

### Shipboard Command Transmitter

Acoustical signals that are frequency-coded are transmitted to the capsule by means of the command transmitter. Three oscillators (A, B, and C), adjustable from 14 to 15 kilohertz, are provided. Coding is accomplished by a front panel switch which selects combinations of any two frequencies: A-B, A-C, or B-C. If these frequencies match filters in the command receiver, solid-state switches are activated. The security of these codes and the method of decoding is discussed below.

The two frequencies selected are alternately transmitted in bursts of 0.33 second for a total transmission time of 5 seconds; the 5-second transmission is repeated every 15 seconds.

The power applied to the transmitting transducer is adjusted by means of a variable autotransformer which controls the voltage applied to the driver circuit of the transducer. A maximum power input of 100 watts provides an acoustical signal of +90 decibels (1 microbar at 1 meter). Calculations in-

dicating that when the ship is at a range of 8 kilometers with the capsule installed at depths as great as 5000 meters, the signal strength at the capsule is sufficiently above the acoustical noise for reliable operation. Experience at sea has confirmed the calculated range, but results vary from test to test. For example, a considerable increase in power usually is needed to command the capsule in the early evening, probably caused by biological noise.

### Command Receiver

The command receiver of the capsule is the most critical unit of the acoustical system. The problem is to provide for a reliable recall, while at the same time avoiding false triggering caused by natural and man-made noise in the sea. The Remaco command receiver meets the requirements of reliability and security in a unique manner. An overdriven input amplifier, which produces a "clipped record" signal, is used

in combination with a three-channel frequency detector to decode acoustical signals (Fig. 7). The outputs of three frequency filters are rectified and smoothed to produce d-c voltages which are applied to a voltage level sensor. If the frequency of an acoustical signal matches a filter, the voltage level sensor produces a "logic-level" signal to the decoder. If a correct combination of acoustical frequencies is present, one of three decoder output lines will be activated.

Of the eight possible combinations of three frequencies, only three are accepted by the decoder. Each code requires that two of the three frequencies be present and the third absent. Requiring one frequency to be absent ensures against false triggering due to noise that may activate all three channels. The code A-C, which requires that the frequency of the missing signal B lie between the frequencies A and C of the transmitted signals, is considered to be most secure and is therefore used to release the capsule. Codes which require one frequency to be present and two absent, or even require all three frequencies to be present, can be used, but since these are relatively insecure, they should be used for noncritical functions.

Security from false triggering resides not only with the frequency filters but also with the overdriven input amplifier. The amplifier improves security by providing a constant total energy to the input of the frequency filters. The reason why this produces better security is evident from a consideration of the following cases. Acoustical noise in the band between 14 and 15 kilohertz, due to a calm (state 2) sea, is sufficient to overdrive the amplifier. A constant-amplitude square wave signal (0 to +6 volts) with random pulse widths appears at the amplifier output regardless of sea state or noise level. The total energy of the amplifier output has nearly uniform distribution across the band between 14 and 15 kilohertz. Each decoding filter then senses a small signal level, which produces about 0.1 volt d-c at the detector output.

If a constant frequency signal (at least 10 decibels above noise level) is present, the energy is concentrated at the fundamental and odd harmonics of the input signal. The odd harmonic frequencies are well outside the band of the filters. If the fundamental

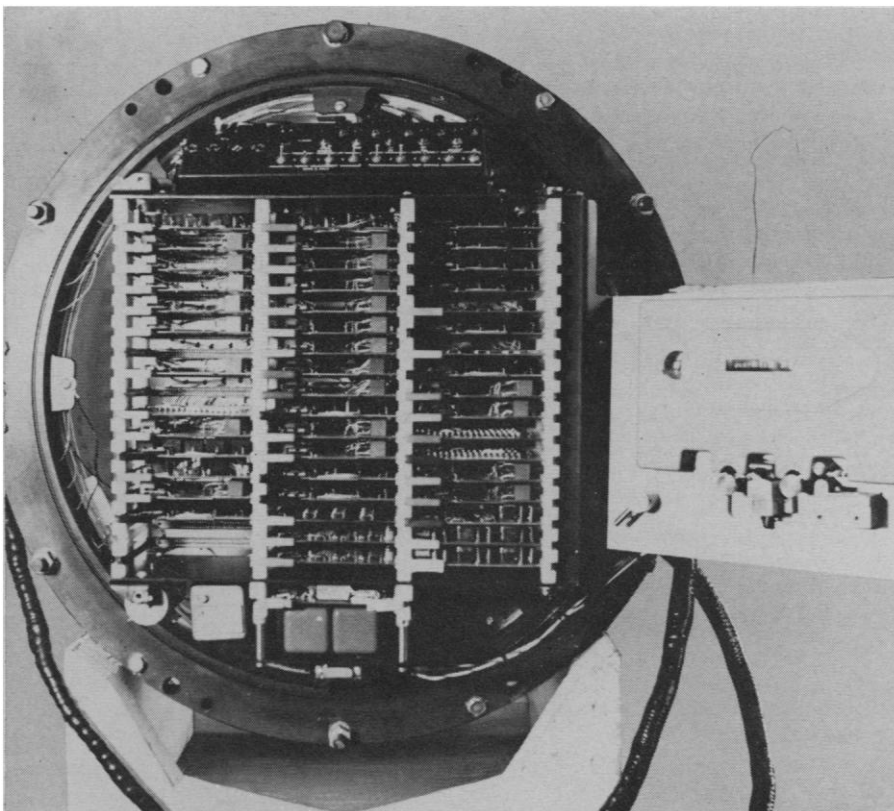

Fig. 6. The digital system is made up of modularized logic elements mounted on 60 plug-in printed circuit boards with provision for "piggyback" light indicators to monitor operation of each card. The Kennedy magnetic tape recorder attaches to the digital system on a hinged plate. The complete system requires approximately 0.25 watt of power.

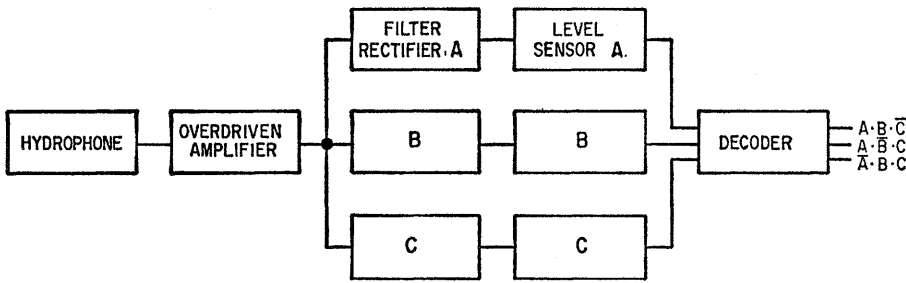

Fig. 7. Command receiver of the capsule decodes acoustical signals sensed by the hydrophone. After amplification the output filters A, B, and C are decoded. Output commands are activated whenever two of three frequencies are present and the third signal is absent.

frequency of the signal matches the filter, a detector output of 3 to 4 volts is produced. An output of 2 volts d-c is sufficient to trigger the decoder.

If simultaneous signals which match two of the frequencies are transmitted, the amplifier output energy is concentrated not only at the fundamental and harmonics of the input signals, but also at their sum and difference frequencies. The output of each detector is less than half that for a single frequency and is not sufficient to trigger either of the decoder inputs.

Triggering of the decoder inputs is accomplished only by transmitting a single frequency at least 10 decibels above the noise level. Triggering of the decoder output can be accomplished only by alternately transmitting two matching frequencies in bursts of 0.33 second. The detector circuit, essentially a peak-reading voltmeter, quickly charges a condenser during the bursts

and then slowly discharges between bursts to produce a smooth signal to the decoder input. The 0.33-second bursts are matched to time constants in the detector circuits.

#### Pinger Circuits

The capsule pinger produces acoustical pulses of 8 kilohertz, 10 milliseconds in duration, at a signal level of +90 decibels (1 microbar at 1 meter) with 140 watts applied to the transducer. Pinger pulses are consistently heard at ranges of 8 kilometers with the capsule in a water depth of 4000 meters. Considerable variation in signal strength has been noted between day and night, probably owing to biological scatterers. In general, measured signal strengths agree with standard calculations of spreading and attenuation losses.

To conserve battery power a combination of low duty cycle and small standby power is used. When an input command pulse is received, power is applied for 10 milliseconds to generate the acoustical pulse; then all circuits are returned to the standby state. If we assume that, on the average, 1 pulse of 10-millisecond duration is generated each second for 2 hours each day, a duty cycle of  $10^{-3}$  is realized. For a circuit efficiency of 0.7 during the pulse, the average power required is about 0.2 watt. Adding a standby power of 0.01 watt, a month's total energy of  $(.2 + .01) 720 = 151$  watt-hours can be supplied by rechargeable batteries within the capsule.

Pinger pulses are produced only when commanded by the pinger input circuits. Programmed pulse codes (Fig. 8) provide an instrument check of the data system, and spontaneous codes provide alert or acknowledgment signals.

#### Pinger Instrument Check

A preset program operates the capsule pinger on a schedule. With the ship continuously on station, the pinger, for example, may be activated 1 hour in every four. For tests lasting a month or more, with the ship not on station for several weeks, the pinger may be programmed to transmit once or twice a day for several days, remain silent for several weeks, and then periodically transmit again when the ship is ex-

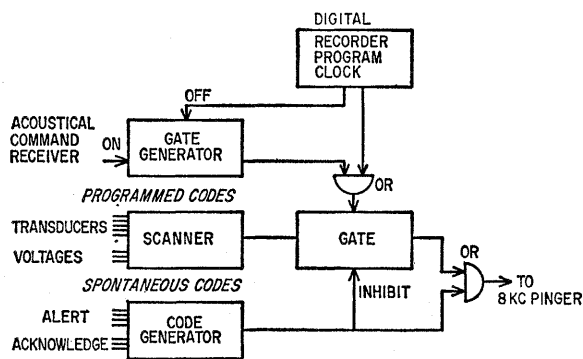
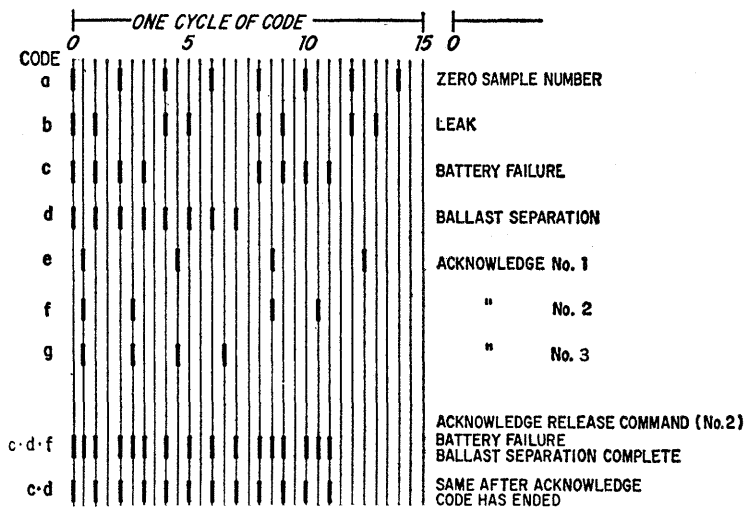

Fig. 8 (left). Pinger system of the capsule provides programmed or commanded instrument checks to monitor five transducers and three battery voltages. Spontaneous codes are automatically transmitted to alert the ship to serious difficulty or to acknowledge commands transmitted by the ship. Fig. 9 (right). Spontaneous pinger codes provide a method for distinguishing any single code or any combination of codes. The number of pulses in a group is equal to the sum groups in the individual codes. The combination of *c* and *d* results in a 12-pulse sequence formed by combination of the four-pulse *c* code with the eight-pulse *d* code. Addition of an acknowledge code produces groups of triple pings for approximately 30 seconds.





pected to return. Pinger transmissions can be initiated between programmed transmissions upon command from the surface ship. Commanded pinger transmissions are terminated by capsule clock circuits. Since the programmed transmission and the "off" signal for the commanded transmissions are obtained from the capsule clock, a comparison of the pinger program with a chronometer aboard ship provides a check of the digital clock.

During the instrument check, pinger pulses are produced from eight test points in the recording system. Each test point is transmitted for 30 seconds, and the scanning sequence is repeated every 4 minutes. During the first five of the eight intervals, pinger pulses are obtained from the binary data counters.

Measurement of the pulse rates (proportional to the frequency of the transducers) provide a direct measure of the transducer's performance. For example, the Dymec transducer has a frequency of 20 kilohertz at a temperature of 15°C. As the temperature decreases to 1°C on the sea floor, the frequency reduces to 6 kilohertz. By selecting the output of the thirteenth binary in the data counter, a pulse is produced every  $2^{13} = 8192$  cycles of the input signal. Thus the ping rate varies from 2.4 to 0.73 pings per second as the capsule descends. Input pulses during the sixth, seventh, and eighth intervals are obtained from voltage-controlled oscillators to provide a direct measure of the various battery voltages.

### Spontaneous Pinger Codes

Time-coded pinger pulses transmitted spontaneously by the capsule provide diagnostic information or alert the ship to serious trouble. Three alert codes, primarily intended for use during the launch and recovery phases of the installation, are activated by water leaks, loss of battery power, and ballast separation. These codes, once initiated, continue until the capsule is recovered. A fourth code, "zero sample number," provides assurance that the capsule "time" has properly been set to zero at the beginning of the data. The code discontinues as soon as data sample number 000000 has been recorded.

Three other spontaneous codes are activated as acknowledgments in response to commands transmitted from the ship. For example, upon command for an instrument check, coded pulses transmitted for about 30 seconds (while the command receiver relays are set) indicate that "command 3" has been received. The acknowledge code is followed by a short pause, then by the instrument check as commanded.

The acknowledgment codes are particularly important in case of a failure. The trouble can then be attributed either to the acoustical system or to instruments in the capsule. Failure of the capsule to transmit an acknowledge code would be followed by further attempts with increased power or better ship positioning, or after rechecking transmitter equipment. If acknowledge codes are received but the capsule fails to respond, failure of capsule circuits

would be indicated and alternate procedures would be attempted.

Coding of the spontaneous pinger pulses (Fig. 9) is such that any one code or combination of codes is distinguishable. A sequence of 16 1-second intervals constitutes one cycle of the codes. Code *a* consists of one transmitted pulse every 2 seconds, code *b* has two pulses, code *c* four, and code *d* eight. Simultaneous transmission of more than one code results in a sequence of pulses with the number of pulses being the sum of the individual codes. A combination of all four codes has a 15-pulse sequence.

Codes *e*, *f*, and *g* (used as acknowledge codes) are formed by using a 2-second interval with a 0.5-second phase delay. Combined with codes *a* through *d*, the 0.5-second phasing produces groups of triple high-speed pings that are easily recognized. For example, upon command to release, the pinger will respond with codes *b*, *c*, and *f*, which indicates that the command was received (code *f*), ballast separation occurred (code *b*), and loss of battery power has taken place (code *c*). Twelve pulses interspersed with triple pings are transmitted. Upon completion of the release command, a 12-pulse sequence (codes *b* and *c*) with a 4-second gap is transmitted until the capsule is recovered.

Spontaneous codes are given priority over instrument checks. Upon completion of the spontaneous code, the pinger pulses for instrument check are automatically resumed.

### Pinger Receiver

The pinger receiver system (Fig. 10) serves two purposes: (i) to monitor the capsule system and (ii) to provide information for navigating the ship during recovery. With the ship on station, a single hydrophone is lowered below the hull of the ship, but while navigating, two hydrophones are towed behind the ship. Amplified pinger pulses, which drive speakers in the laboratory and on deck, are displayed on an oscilloscope. The amplified signal is also rectified and filtered to produce 10-millisecond pulses for recording on a strip chart recorder (Sanborn) and as input to a time interval meter.

During instrument checks pinger pulse intervals of noisy signals are most easily measured acoustically with a stop-

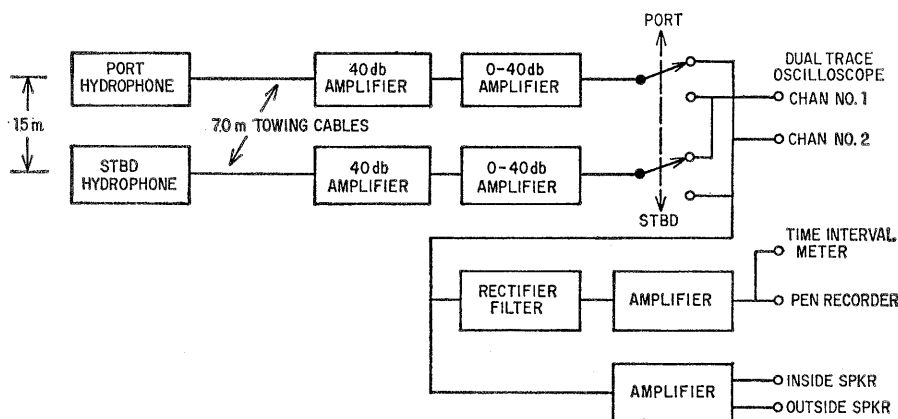

Fig. 10. The ship is navigated directly over the capsule on the bottom by comparing the time delay of pinger signals received by two hydrophones towed from the stern of the ship. In addition to the oscilloscope used for time delay measurements, direct outputs are provided for two acoustical speakers. After the pinger pulses have been rectified, filtered, and amplified, outputs are provided for a pen recorder and time interval meter to decipher diagnostic codes transmitted by the capsule.

watch. Reasonably noise-free signals are measured with a time interval meter to an accuracy of  $\pm 1$  millisecond (0.1 percent) to provide a quantitative measurement of the transducer frequencies and battery voltages.

Spontaneous pinger codes are deciphered by counting the pulses in the sequence of the audible signals or by studying the strip chart recordings. Signal details such as pinger signal strength, pulse shape, echo pulses, and time delays between the two hydrophones are obtained from the oscilloscope.

### Pinger Navigation

When pinger pulses are used to navigate, two hydrophones, separated 15 meters by outriggers mounted at the stern of the ship, are towed at a low speed. Relative bearings to the capsule are indicated by the difference in arrival time of the pinger pulses at the

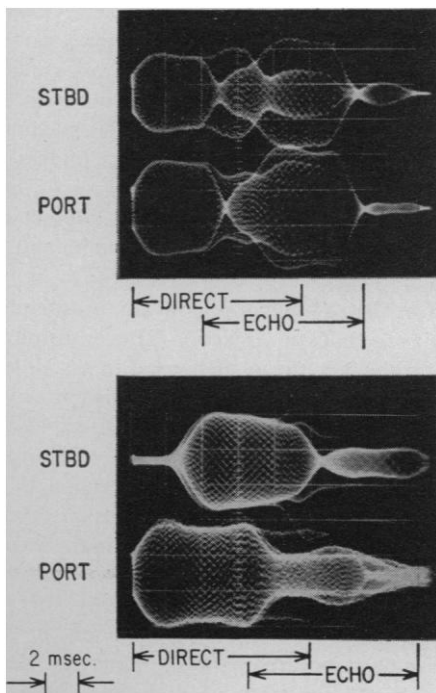

Fig. 11. Simultaneous signals in upper oscillograms indicate that the capsule is located along the axis of the ship. Turning the ship to starboard causes the starboard signal to be delayed in the lower oscillogram, which indicates that the capsule is ahead. Oscillograms with multiple exposures show variability of the signal envelope caused by superposition of surface echo. Increased time delay of the echo and greater signal strength in the lower oscillogram indicate that the ship is approaching the capsule.

two hydrophones. Hydrophone signals (Fig. 11) are observed on a dual trace oscilloscope.

By operating a "port-starboard" switch the horizontal sweep is synchronized with the hydrophone which first receives a pulse. The second pulse then is displayed along the axis a distance equal to the time delay. The switch position, port or starboard, indicates that the capsule corresponds to the port or starboard of the ship. The ship's heading is changed until the time delay is zero. The question of whether the capsule is ahead or astern is resolved by maneuvering the ship. Turning the ship to starboard should cause a bearing indication to the port side of the ship if the capsule is ahead, or to the starboard side if the capsule is astern.

The distortion of the pinger pulse envelope seen in the oscillogram (Fig. 11) is due to the echo of the sea surface. As the ship approaches a position above the capsule, the time delay of the echo pulse increases. Directly above the capsule, the time delay is 10 milliseconds (towed hydrophone depth is 7.6 meters) which barely separates the direct and echo pulses.

As a further aid in the navigation of the ship, range measurements are made by measuring the time delay of the surface echo. The delay of the echo pulse is

$$\Delta t = (L_1 - L_2)/v$$

where  $L_1$  is the length of the direct path,  $L_2$  is the length of the path including a single reflection from the surface, and  $v$  is the velocity of sound in seawater (Fig. 12). The system behaves as though a second hydrophone is being used which is located a distance above the surface equal to the depth of the actual hydrophone. When the pinger is located directly below the listening hydrophone at depth  $h$ , the echo time delay

$$t_0 = 2h/v$$

For a ship at range  $r$  in a water depth  $d$ , the time delay is

$$\Delta t = t_0(1 + (r/d)^2)^{-1/2}$$

for  $d \gg h$ , if we assume unrefracted propagation paths.

Measurements in 1800 meters of water indicate that the linear approximation

$$\Delta t = t_0(1 - r/3.5d)$$

can be used for  $0 < r < 3.5d$ , with  $\Delta t = 0$  for  $r > 3.5d$ . Evidently, the assumption of unrefracted paths is valid only for  $r < 2d$ .

Data points indicated in Fig. 12 are scattered owing to difficulty in reading the oscillograms (Fig. 13) and the uncertainty of the ship's position. The ship was allowed to drift in order that a maximum hydrophone depth could be obtained. For these tests the location of the capsule was marked by a surface buoy moored with a polypropylene line which is 1.1 times the depth of the water. The hydrophone depth,  $h$ , was accurately determined by means of a pressure transducer attached to the hydrophone.

### General Recovery System

Release of the ballast occurs whenever the linkage between the instrument frame and the ballast is broken by activation of either a solenoid device or an exploding bolt (Fig. 1). The re-

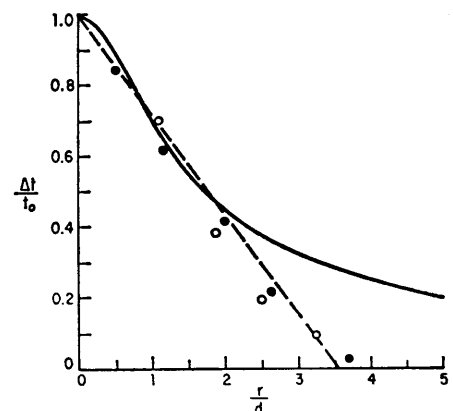
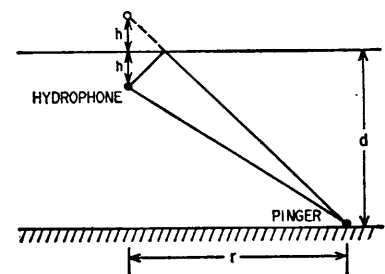

Fig. 12. If we assume unrefracted acoustic paths, the range,  $r$ , of the capsule on the bottom can be calculated from measurements for surface echo time delay,  $\Delta t$ , if the hydrophone depth,  $h$ , water depth,  $d$ , and sound velocity,  $v$ , are known. The unrefracted path assumption (solid line) matches data obtained at sea only for  $r < 2d$ ; a linear approximation to the data (dashed line) is adequate for navigating the ship.



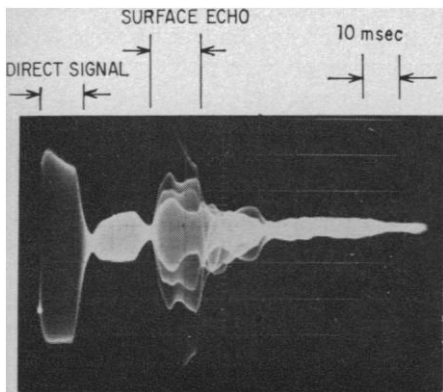

Fig. 13. Direct and surface echo signals recorded for  $d = 1800$  meters and  $h = 34$  meters. For  $\Delta t = 26$  milliseconds the capsule range  $r = 2650$  meters. Multiple exposure of four consecutive pulses shows stability of the direct pulse and variability of the surface echo.

lease circuits (Fig. 14) are arranged so that acoustical release commands from the ship are directed alternately to the solenoid and the bolt. If neither the solenoid nor the bolt can be activated, a 60-day timer (Bulova) activates the exploding bolt at a preset time and date. Release circuits also are activated by a leak detector which senses the presence of a small amount of water in either sphere.

A solenoid device was selected as the primary release in order to ensure that the prelaunch check be as complete as possible. The ballast is attached to the instrument frame with attaching bolts drawn to full tension and the cable is connected as intended in actual use. An acoustical command is then transmitted to the capsule on deck to check the operation of the complete

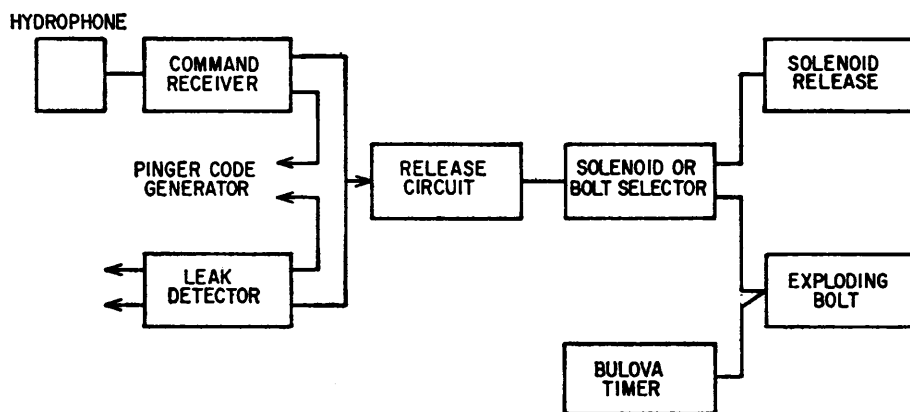

Fig. 14. The ballast can be released by either a solenoid device or an exploding bolt. The devices are activated upon acoustical command from the surface ship or by a preset Bulova timer. Provision is also made for release if a leak develops in either sphere. Acoustical pinger codes acknowledge the ship command for release or warn of water leaks.

system. A second acoustical command checks the explosive bolt circuit with a dummy load and voltmeter used in place of the bolt.

The Bulova timer, installed in a separate pressure case on the instrument frame (Fig. 1), is connected directly to the exploding bolt. In presetting the clock a dilemma always exists. Selecting a time close to the proposed recovery precludes any delay due to ship schedule or bad weather. Ship scheduling necessitates a long expensive standby if the primary acoustical release system fails. A 2-day delay was considered a reasonable compromise.

Redundancy in the release system is such that a single difficulty will not cause a failure of both the primary and secondary systems. Entirely different devices are used in order that unpredicted trouble is unlikely to cause failure in both systems. Provision is not made for two or more simultaneous failures.

The restrained, off-center hook design used in the solenoid trigger is shown in Fig. 15. The load, applied through a stirrup to allow the hook to rotate, is offset 3 millimeters from the center line of the pivot. Roller wheels, loosely coupled to the solenoid plunger, prevent the hook from rotating and allow the armature to align freely with the closely fitted solenoid coil. Small diameter rollers close to the end of the hook arm provide low friction and small plunger motion. Loads of 300 kilograms can be released with an impulse of 1 watt-second to the coil. The release circuit provides an impulse of 10 watt-seconds ( $10^4$ -microfarad condenser charged to 45 volts).

## Surface Recovery

During the 1- to 1.5-hour ascent, the pinger transmits continuously and allows acoustical tracking by the ship. At a depth of approximately 30 meters, a pressure switch activates a 4.4-megacycle radio beacon and a flashing light. A second radio beacon operating at 27 megacycles is activated as soon as its antenna is no longer short-circuited by the seawater. If the sea is exceptionally calm, radar sightings are possible, but because of the small exposed area of the capsule, sea return usually obscures the radar echoes. Radar transponders have been considered but have been discarded in favor of radio beacons.

The 4.4-megacycle radio beacon is mounted in the top sphere with the antenna lead penetrating the center of the sphere. The antenna, approximately 8 feet (2.4 meters) in length, is a helically wound whip made of fiber glass. By concentrating the helix at the center of the whip, the antenna is matched to the transmitter and made relatively free from ground plane effect. Pulses of 3-second duration with a peak power of 2.5 watts are transmitted once every 30 seconds. The 3-second duration of the transmitted signal provides adequate time for automatic direction finders to lock on the bearing. The signals can be heard at a range of 50 kilometers; directional bearings can be obtained at a range of 25 kilometers.

The 27-megacycle radio is intended as a backup beacon. The transmitter with its batteries is housed in a stainless steel case with the antenna attached at one end. Pulses, 50 milliseconds in duration with a peak power of 2 watts, are transmitted each 0.5 second. The signals can be heard at a range of 25 kilometers. Directional bearings are obtained from hand-held loop antenna receivers. The bearings usually contain large errors caused by resonance of the superstructure of the ship, but the "dead ahead" indications with the receiver operated at the bow of the ship are reliable for directing the ship to the capsule.

The capsule's flashing light is mounted about 1 meter above the water at the base of the radio beacon antennas. Light flashes of 0.5 watt-second (5 microfarads at 450 volts) are produced at an interval of about 3 seconds. The flashes can be seen at a range of 3 kilometers with normal visibility and

provide a means of approaching the buoy if a night recovery is necessary. Except for the power supply inside the sphere, the flash tube and its circuits are contained in a Lucite pressure case.

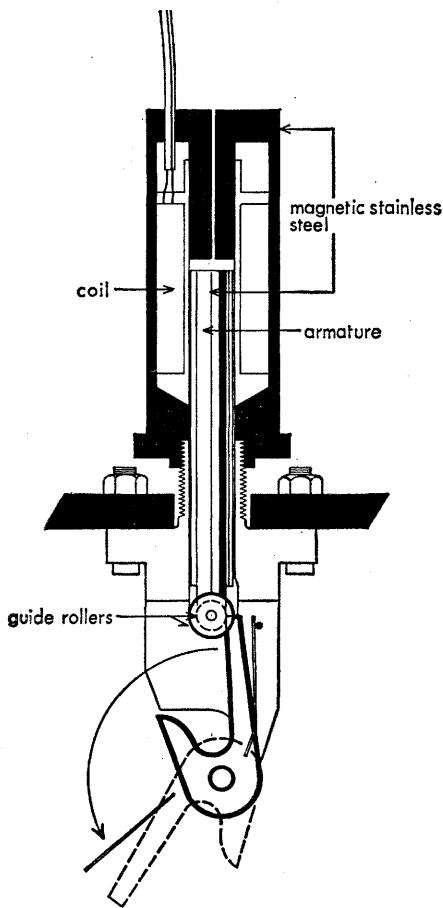

Fig. 15. Three rollers (two of which press against the rigid frame while the third, smaller roller restrains the hook) provide a low friction device. A short-stroke, close-fitting armature reduces power requirements.

## Batteries

Fourteen separate battery supplies are used to meet a variety of needs in voltage, peak current, total energy, and circuit isolation. Inside the capsule mercury batteries are used where constant voltage is important; rechargeable alkaline batteries are used for their favorable energy-to-weight ratio; and carbon-zinc batteries are used for non-critical applications. External to the capsule inexpensive lead-acid batteries are used. These yield a large total energy and are easily adapted for high underwater pressure.

Ten lead-acid truck batteries (150 ampere-hours) provide power for the current meters, the digital system, and the tape recorder. Weighing about 90 kilograms in water, the batteries also act as an anchor for the capsule. When the capsule is recovered, the batteries are left on the bottom. Underwater electrical connectors to the battery are easily parted by the buoyant force of the capsule.

A special oil mixture (used by the Wisco Company, Racine, Wisconsin, in their oceanographic batteries) which has a specific gravity of 1.11 (midway between that of the seawater and the battery acid) provides an isolating barrier between the acid and the seawater.

Just prior to installation in the sea, oil is added to fill the void in the battery above the acid. Polyvinyl chloride tubes (2.5 centimeters in internal diameter, 10 cm in length) cemented to the battery case over the battery caps are also filled with oil. A simple cap with a small hole prevents spillage

of the oil during handling of the batteries and also provides free access to the seawater.

The required electrical leads are attached to the battery posts with self-tapping screws. The entire battery assembly is then covered with a 5-centimeter layer of nonhardening battery tar to seal the electrical leads and to secure the filling tubes in position.

A lead-acid lawn mower battery (27 ampere-hours), installed in an oil-filled case, supplies power for the flashing light and radio beacons. The oil floods freely into the battery to fill all voids above the acid. An elastic diaphragm seals the case. A fitting at the center of the diaphragm allows battery gases generated during charging to escape. The decreased fluid volume caused by increased pressure and decreased temperature plus the volume of bubbles trapped in the battery is compensated for by motion of the elastic diaphragm.

Battery voltage data, transmitted to the surface by the pinger, indicates that the lead-acid batteries operate satisfactorily under high pressure at temperatures near 0°C. The battery voltage is slightly lower (probably owing only to the lower temperature), but the total energy available from the battery is essentially equal to that obtained at normal temperature and pressure.

## References and Notes

1. W. H. Munk and B. D. Zetler, *Science* **158**, 884 (1967).
2. M. Eyries, *Cahiers Oceanogr.* **20**, 355 (1968).
3. J. H. Filloux, *Oceanogr. Abstr. Amer. Geophys. Union* **49**, 211 (1968).
4. D. R. Caldwell, in preparation.
5. All major components for the acoustical system were purchased from the Research Manufacturing Company, San Diego, California.
6. Supported by the U.S. Office of Naval Research under contract Nonr-2216(12).