



MAX497 Evaluation Kit

General Description

The MAX497 evaluation kit (EV kit) simplifies the evaluation of the MAX496 and MAX497 quad video buffers. RF-style connectors (SMA) and 75Ω terminating resistors are included for video test equipment compatibility.

The evaluation board comes with the MAX497 installed, but can also be used to evaluate the MAX496. Simply contact Maxim's Sample Department to order a MAX496CSE free sample, and replace the MAX497 with the MAX496; no other changes are necessary.

Component List

DESIGNATION	QTY	DESCRIPTION
C1, C2	2	10μF, 10V, 20% tantalum capacitors Sprague 293D106X0016B or AVX TAJB106M016
C3-C6	4	0.1μF ceramic capacitors Vitraron VJ1206Y104KXX
IN0-IN3, OUT0-OUT3	8	SMA connectors
R1-R8	8	75Ω, 5% resistors
U1	1	MAX497CSE
None	1	MAX496/MAX497 PC board

Component Suppliers

SUPPLIER	PHONE	FAX
AVX	(803) 946-0690	(803) 626-3123
Sprague	(603) 224-1961	(603) 224-1430
Vishay/Vitramon	(203) 268-6261	(203) 452-5670

Features

- ◆ **375MHz -3dB Bandwidth (MAX496)**
275MHz -3dB Bandwidth (MAX497)
- ◆ **Low Differential Gain/Phase Error: 0.01%/0.01°**
- ◆ **1500V/μs Slew Rate (MAX497)**
- ◆ **5.6nV/√Hz Input-Referred Voltage Noise**
- ◆ **Directly Drives 50Ω/75Ω Back-Terminated Cable**
- ◆ **Fully Assembled and Tested**
- ◆ **±5V Supply**

Ordering Information

PART	TEMP. RANGE	BOARD TYPE
MAX497EVKIT-SO	0°C to +70°C	Surface Mount

Note: To evaluate the MAX496, request a MAX496CSE free sample.

Quick Start

The MAX497 EV kit is fully assembled and tested. Follow these steps to verify board functionality. Do not turn on the power supply until all connections are completed.

- 1) The circuit requires 5V supply voltages. Connect the +5V supply to the pad marked VCC, and the -5V supply to the pad marked VEE. Connect power-supply ground to the pad marked GND.
- 2) Connect a 75Ω cable from a signal source to the input marked IN0.
- 3) Connect the output marked OUT0 to an oscilloscope through a terminated 75Ω cable.
- 4) Turn on the power supply, apply a 1.25V (maximum) signal, and verify the output signal on the oscilloscope.

Detailed Description

The MAX496/MAX497 operate from 5V supplies. SMA jacks are provided for all input and output signals. The MAX496 allows ±2.5V input signal levels and the MAX497 accepts levels to ±1.25V.

Evaluates: MAX496/MAX497

MAX497 Evaluation Kit

Driving Coaxial Cable

The MAX497 EV kit is designed to drive a terminated 75 Ω video cable. The back-termination resistor is included to match the impedance of the cable's driven end to the characteristic impedance of the cable itself. For 50 Ω systems, replace the 75 Ω termination resistors (R1–R8) with 50 Ω resistors. This, along with the load termination resistor, eliminates signal reflections from the cable's ends. The back-terminating resistor forms a voltage divider with the load impedance, which attenuates the signal at the cable's output by one-half. The MAX497 operates with a 2V/V closed-loop gain to provide unity gain at the cable's output. With the MAX496 installed, the overall gain is reduced to one-half the input signal when driving a terminated cable.

Layout Considerations

The MAX497 evaluation board layout is optimized for high-speed signals, giving careful attention to grounding, power-supply bypassing, and signal-path layout. The small, surface-mount ceramic bypass capacitors C3–C6 have been placed as close to the MAX497 supply pins as possible. Back-termination resistors were placed as close to the MAX496/MAX497 as possible to isolate board capacitance. For further layout recommendations, refer to the *Grounding and Layout* section of the MAX496/MAX497 data sheet.

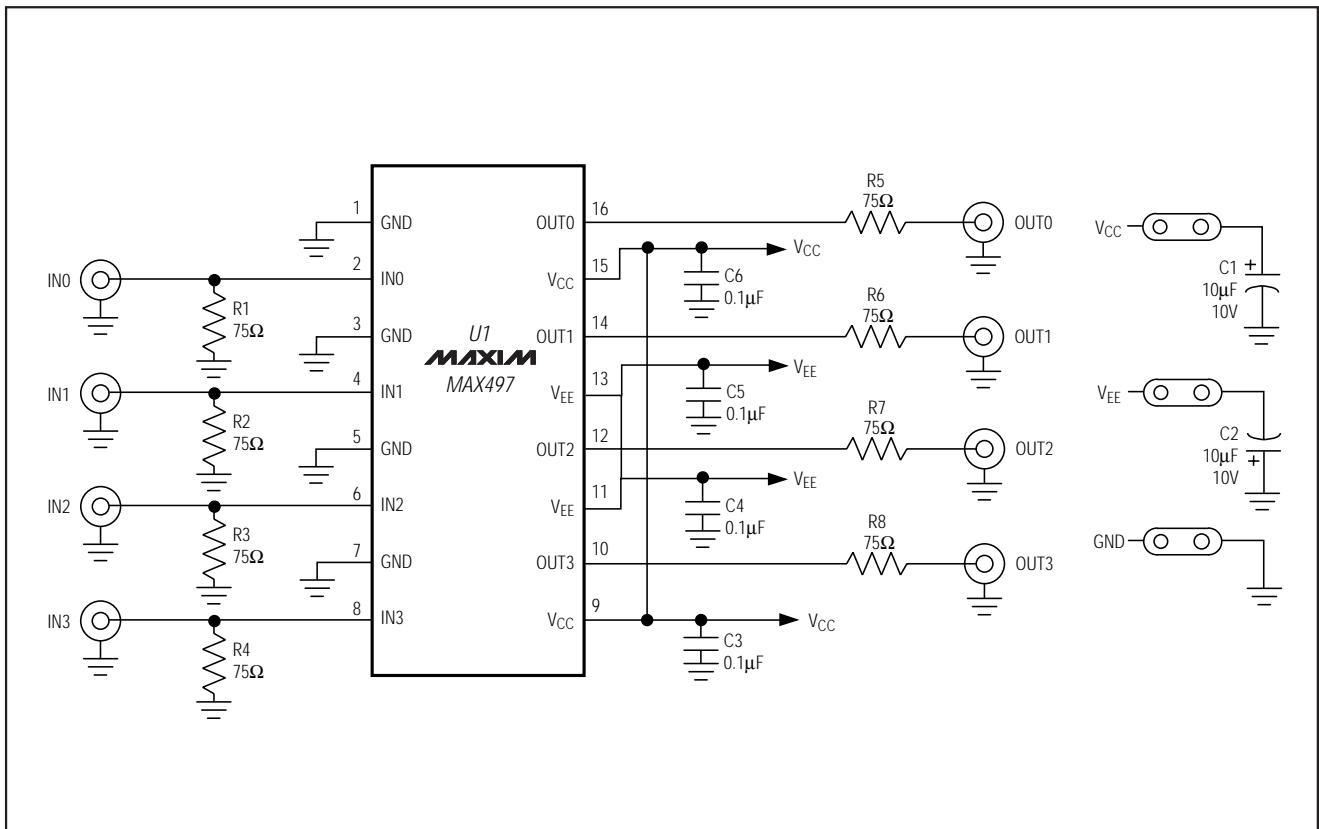

Figure 1. MAX497 EV Kit Schematic

MAX497 Evaluation Kit

Evaluates: MAX496/MAX497

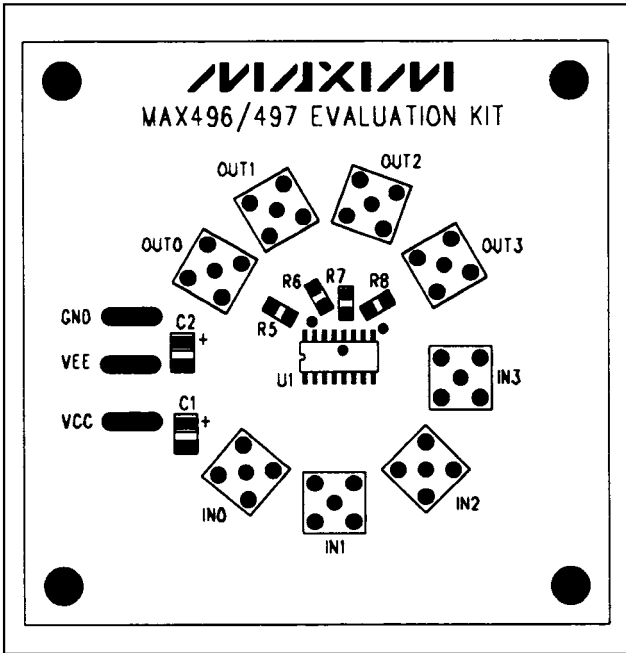

Figure 2. MAX497EV Kit Component Placement Guide—Component Side

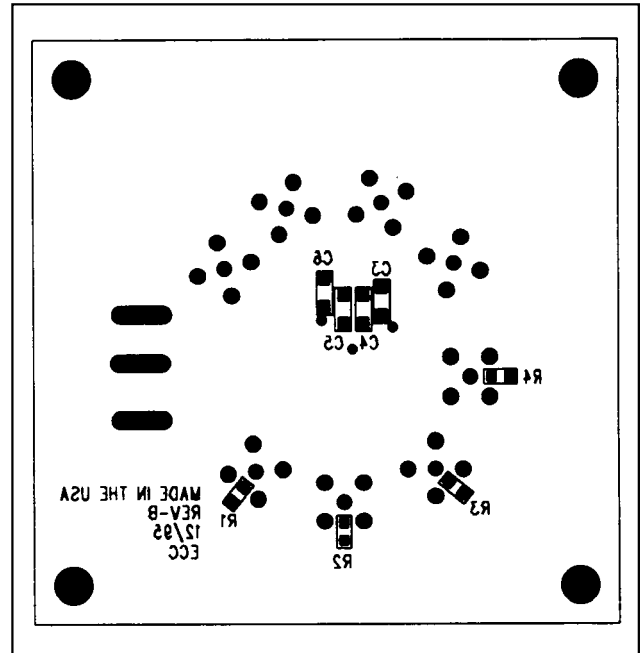

Figure 3. MAX497EV Kit Component Placement Guide—Solder Side

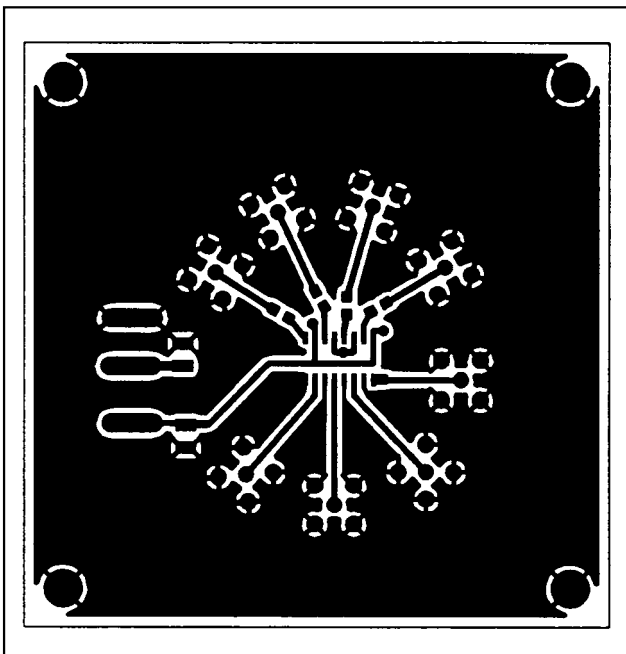

Figure 4. MAX497EV Kit PC Board Layout—Component Side

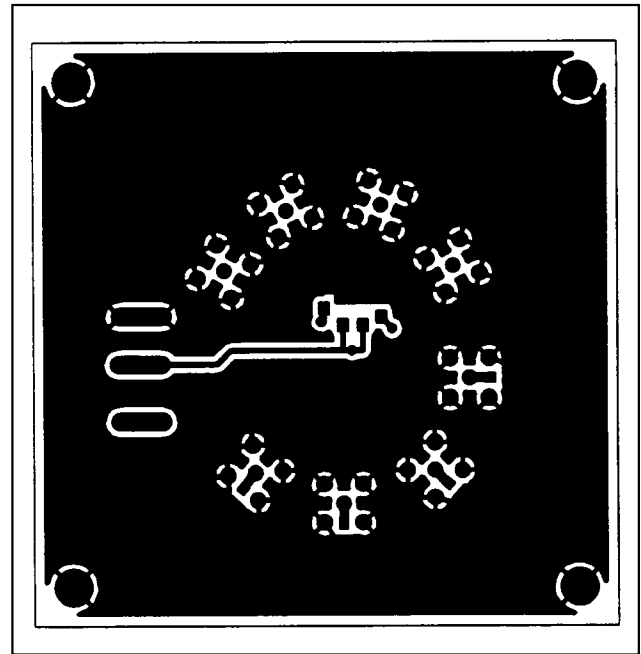

Figure 5. MAX497EV Kit PC Board Layout—Solder Side

MAX497 Evaluation Kit

Evaluates: MAX496/MAX497

NOTES

Maxim cannot assume responsibility for use of any circuitry other than circuitry entirely embodied in a Maxim product. No circuit patent licenses are implied. Maxim reserves the right to change the circuitry and specifications without notice at any time.

4 _____ Maxim Integrated Products, 120 San Gabriel Drive, Sunnyvale, CA 94086 408-737-7600

© 1998 Maxim Integrated Products

Printed USA

MAXIM is a registered trademark of Maxim Integrated Products.