

300 mA LOW DROPOUT POSITIVE
ADJUSTABLE REGULATOR

PRELIMINARY DATASHEET

FEATURES

- SOT-23 Package
- Stable with 2.2µF Ceramic Capacitor
- 1% Voltage Reference Accuracy
- Only 270mV Dropout at 300mA
170mV Dropout at 150mA
- 10nA Quiescent Current in Shutdown
- Current Limit and Thermal Shutdown
- Logic input Enable pin

DESCRIPTION

The IRU1205 device is an efficient linear voltage regulator with better than 1% initial voltage accuracy, very low dropout voltage and very low ground current designed especially for hand held, battery powered applications. Other features of the device are: TTL compatible enable/shutdown control input, current limiting and thermal shutdown.

The IRU1205 is available in fixed and adjustable output voltage versions in a small SOT23-5 package.

APPLICATIONS

- Laptop, Notebook & Palmtop computers
- Battery powered Equipments
- PCMCIA Vcc & Vpp regulator
- Consumer Electronics
- High Efficiency Linear Power Supplies

TYPICAL APPLICATION

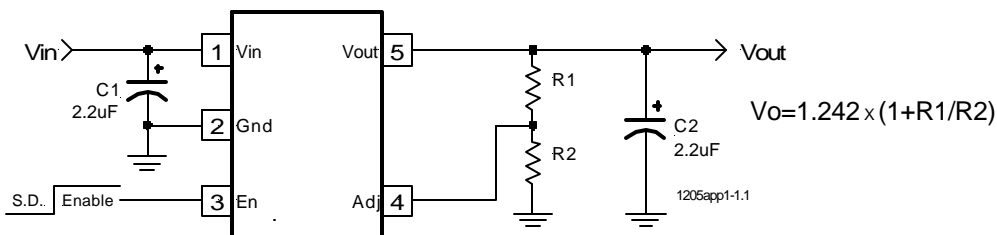

Typical application of the IRU1205 adjustable

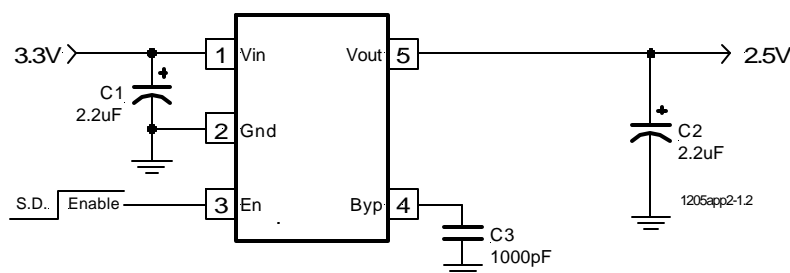

Typical application of the IRU1205 Fixed voltage

PACKAGE ORDER INFORMATION

Tj (°C)	5-LEAD SOT-23	SOT-23 MARKING	OUTPUT VOLTAGE
0 TO 125	IRU1205CL	AT00	Adj
0 TO 125	IRU1205-25CL	AT25	2.5 V
0 TO 125	IRU1205-30CL	AT30	3.0 V
0 TO 125	IRU1205-33CL	AT33	3.3 V
0 TO 125	IRU1205-36CL	AT36	3.6 V

IRU1205

ABSOLUTE MAXIMUM RATINGS

Input Voltage (V_{in})	10V
Enable Input Voltage	10V
Storage Temperature Range	-65°C TO 150°C
Operating Junction Temperature Range	0°C TO 150°C

PACKAGE INFORMATION

5-PIN SOT-23 (L) Adjustable	5-PIN SOT-23 (L) Fixed

ELECTRICAL SPECIFICATIONS

Unless otherwise specified, these specifications apply over, $C_{in}=C_{o}=22\mu$, $I_{o}=100\mu A$, $V_{inmin}=2.5V$ (Adjustable devices) $V_{in}=V_{o}+1V$ (for fixed voltage devices), $V_{out}=V_{fb}$ (for adjustable version only), $C_{byp}=470pF$ (for fixed output versions only), $V_{enb}=2V$ and $T_a=25^\circ C$. Typical values refer to $T_a=25^\circ C$. Low duty cycle pulse testing are used which keeps junction and case temperatures equal to the ambient temperature.

PARAMETER	SYM	TEST CONDITION	MIN	TYP	MAX	UNITS
Reference Voltage See Table 1 for typical values	V_o	(Note 4)	-1 -2		1 2	%
Line Regulation	dV_i	$V_o+1V < V_{in} < 10$		0.005		%/V
Load Regulation (note 1)	dV_L	$1mA < I_o < 100mA$		0.8		%
		$100mA < I_o < 300mA$		0.1		%
Dropout Voltage (note 2)	dV_{io}	$I_o=100\mu A$		10	50	mV
		$I_o=100\mu A$ (Note 4)		13	70	mV
		$I_o=50mA$		85	110	mV
		$I_o=50mA$ (Note 4)		100	140	mV
		$I_o=150mA$		170	220	mV
		$I_o=150mA$ (Note 4)		204	260	mV
		$I_o=300mA$		270	350	mV
		$I_o=300mA$ (Note 4)		324	400	mV
Ground Current (Note 3)	I_q	$V_{en}=2V$, $I_o=100\mu A$		120	160	μA
		$I_o=100\mu A$ (Note 4)		240		μA
		$I_o=50mA$		420	600	μA
		$I_o=50mA$ (Note 4)		540		μA
		$I_o=150mA$		2200	2900	μA
		$I_o=150mA$ (Note 4)		2900		μA
		$I_o=300mA$		7200	9500	μA
		$I_o=300mA$ (Note 4)		9300		μA
Ground Current-S.D Activated	I_{qsd}	S.D pin<0.1V S.D pin=0.8V		0.1 8		μA
Current Limit	I_{cl}	$V_o=0V$	320	420		mA
Thermal Regulation	dV_p	$V_{in}=10V$, $I_o=150mA$, 10mS Pulse		0.05		%/W
Adjust Pin Current	I_{adj}	$V_{in}=2.5V$, $V_o=V_{adj}$		0.1		μA
Enable pin input LO voltage	V_{enl}	Regulator OFF			0.8	V
Enable pin input HI voltage	V_{enh}	Regulator ON	2			V
Enable pin input LO current		$V_{enl}=0V$ to 0.8V		0.01		μA
Enable pin input HI current		$V_{enh}=2V$ to V_{in}		20		μA

Note 1: Low duty cycle pulse testing with Kelvin connections are required in order to maintain accurate data.

Note 2: Dropout voltage is defined as the minimum differential voltage between V_{in} and V_{out} required to maintain regulation at V_{out} . It is measured when the output voltage drops 1% below its nominal value.

Note 3: Ground current is the the regulator quiescent current plus the pass transistor current. The total current from the supply is the sum of the load current plus the ground pin current.

Note 4: The specification applies for the junction temperature of 0 to +125°C.

Pin DESCRIPTIONS

PIN #	PIN SYMBOL	PIN DESCRIPTION
4	Adj (Adjustable only)	A resistor divider from this pin to the V_{out} pin and ground sets the output voltage.
4	Byp (Fixed output only)	A 470 to 1000pF bypass capacitor connected to this pin reduces the output noise.
5	V_{out}	The output of the regulator. A minimum of 2.2 μ F with max ESR of 1 ohm capacitor must be connected from this pin to ground to insure stability.
2	GND	Ground pin. This pin must be connected to the lowest potential in the system and all other pins must be at higher potential with respect to this pin.
3	En	Enable pin. A low signal or left open on this pin shuts down the output. This pin must be tied HI or to V_{in} for normal operation.
1	V_{in}	The input pin of the regulator. Typically a large storage capacitor is connected from this pin to ground to insure that the input voltage does not sag below the minimum dropout voltage during the load transient response. This pin must always be higher than V_{out} by at least the amount of the dropout voltage and some margin in order for the device to regulate properly.

5-LEAD SOT-23	Output Voltage
IRU1205	1.242V
IRU1205-25	2.5 V
IRU1205-30	3.0 V
IRU1205-33	3.3 V
IRU1205-36	3.6 V

The output voltage of the adjustable device can be set using:

$$V_o = 1.242 \times (1 + R_1/R_2)$$

Where;

R1=Resistor connected from output to the Adj pin

R2=Resistor connected from Adj pin to GND

Table 1- Nominal output voltage vs. part number

BLOCK DIAGRAM

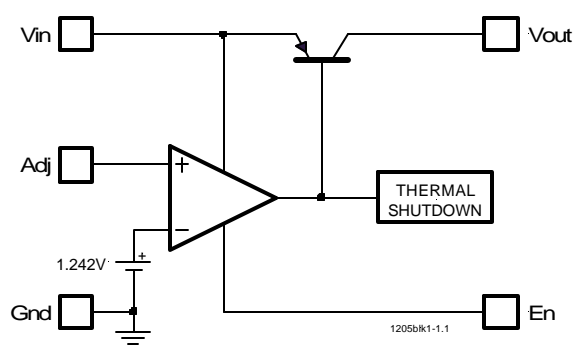

Figure 1- IRU1205 Adjustable block diagram

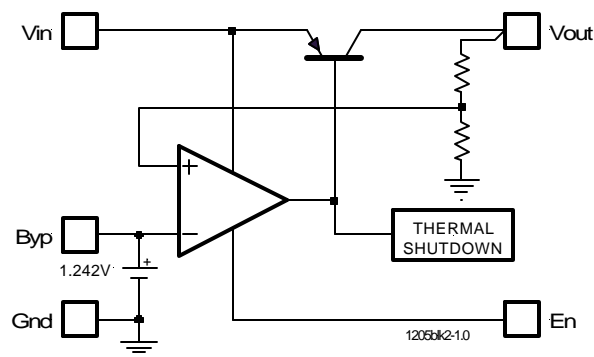

Figure 2- IRU1205 Fixed output block diagram

