

3V recording / playback system preamplifier

BA3410AF

The BA3410AF is a playback/recording system preamplifier for mono tape recorders. It operates off a 3V supply. The BA3410AF includes playback equalizer, mic, line, and recording amplifiers, an ALC circuit, and a playback/recording control circuit. This construction allows switching between recording and playback modes with a single contact switch, for smaller and simpler PCB designs.

When combined with a BTL power amplifier, almost all of the functions required for a 3V personal-memo or dictation tape recorder are provided, allowing compact set designs.

● Applications

3V personal-memo tape recorders

● Features

- 1) Internal recording/playback mode switch requires just a single contact switch.
- 2) Recording monitoring is possible.
- 3) Direct-head coupling is possible for playback.
- 4) Low power dissipation (recording: 4.8mA, playback: 3.8mA).
- 5) 16-pin SOP package allows compact set designs.

● Block diagram

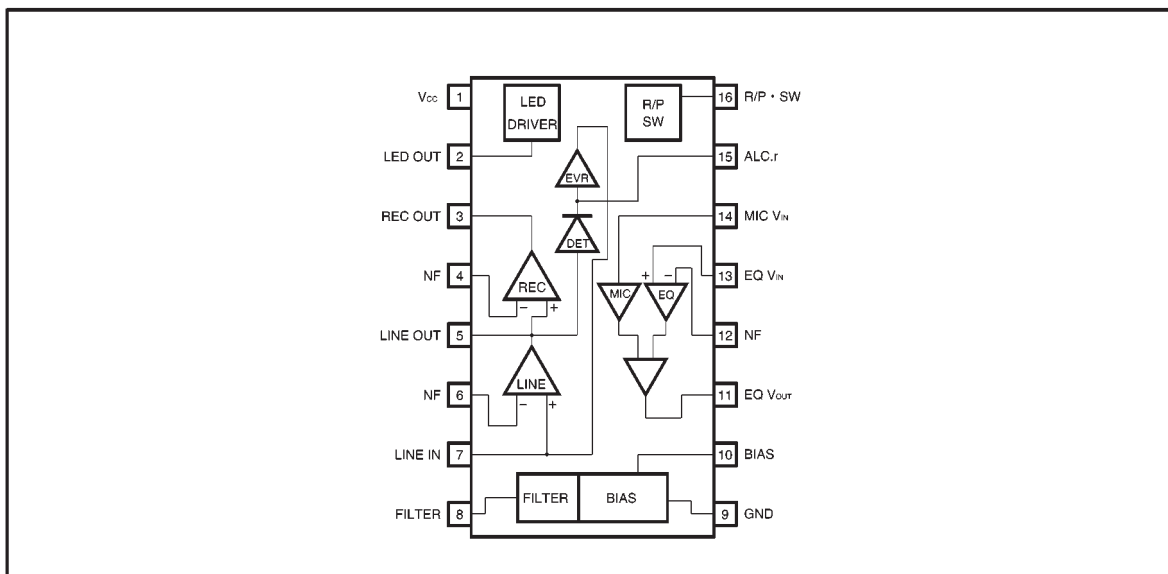

● Absolute maximum ratings (Ta = 25°C)

Parameter	Symbol	Limits	Unit
Power supply voltage	V _{CC}	4.0	V
Power dissipation	P _d	500*	mW
Operating temperature	T _{opr}	-20~+75	°C
Storage temperature	T _{stg}	-40~+125	°C

* When mounted on a 50mm×50mm×1.6mm glass epoxy board. Reduced by 5.0mW for each increase in Ta of 1°C over 25°C.

● Recommended operating conditions (Ta = 25°C)

Parameter	Symbol	Min.	Typ.	Max.	Unit
Power supply voltage	V _{CC}	1.8	3	3.5	V

● Electrical characteristics (unless otherwise noted, Ta = 25°C, V_{CC} = 3V and f = 1kHz)

Parameter	Symbol	Min.	Typ.	Max.	Unit	Conditions
Recording quiescent current	I _{Q R}	2.3	4.8	7.2	mA	V _{IN} =0V _{rms}
Playback quiescent current	I _{Q P}	1.8	3.8	6.2	mA	V _{IN} =0V _{rms}
Open loop voltage gain (1)	G _{vo} -EQ	59	70	—	dB	V _{IN} =-90dBV
Closed loop voltage gain (2)	G _{vc} -EL	40	44	48	dB	V _{IN} =-64dBV
Closed loop voltage gain (3)	G _{vc} -ML	47	50	53	dB	V _{IN} =-75dBV
Closed loop voltage gain (4)	G _{vc} -MR	60	64	67	dB	V _{IN} =-80dBV
Maximum output voltage	V _{OM} -R	400	500	—	mV _{rms}	THD=1%
Distortion (1)	THD-EL	—	0.1	0.7	%	V _{IN} =-54dBV
Distortion (2)	THD-MR	—	0.4	1.5	%	V _{IN} =-60dBV
Distortion (3)	THD-MR	—	0.3	1.5	%	V _{IN} =-32dBV
LED output current (1)	I _{OL} -P1	20	50	—	μA	V _{CC} =2.3V
LED output current (2)	I _{OL} -P2	—	0	10	μA	V _{CC} =1.7V
Input conversion noise voltage (1)	V _{NIN PL}	—	1.2	2.0	μV _{rms}	R _g =2.2kΩ, BPF=20~20kHz
Input conversion noise voltage (2)	V _{NIN PL}	—	1.4	2.0	μV _{rms}	R _g =2.2kΩ, BPF=20~20kHz

● Measurement circuit

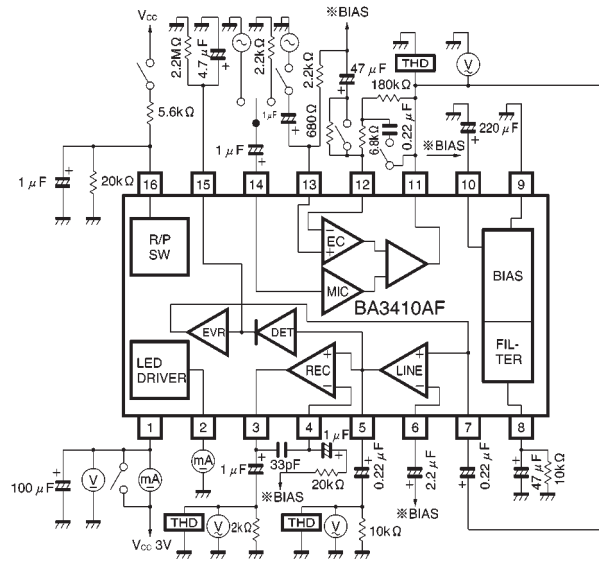

Fig. 1

● Electrical characteristics curves

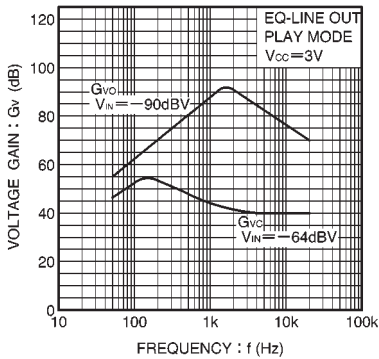

Fig. 2 Voltage gain vs. frequency

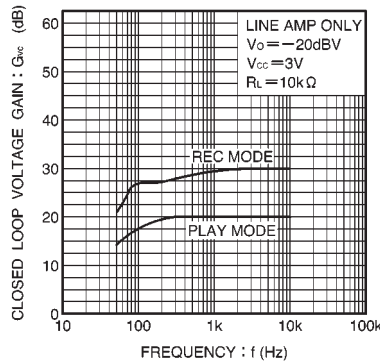

Fig. 3 Voltage gain vs. frequency

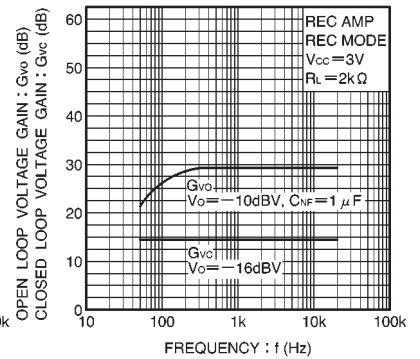

Fig. 4 Voltage gain vs. frequency

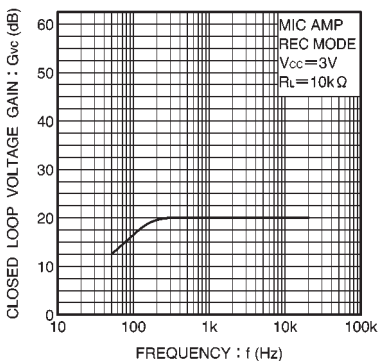

Fig. 5 Voltage gain vs. frequency

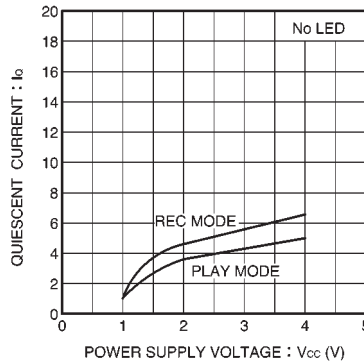

Fig. 6 Quiescent current vs. power supply voltage

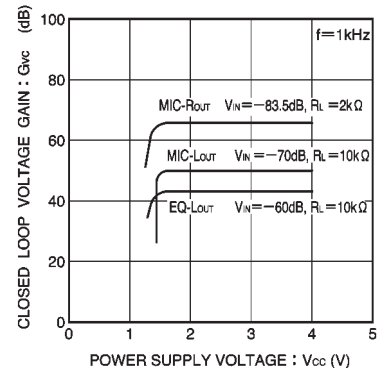

Fig. 7 Voltage gain vs. power supply voltage

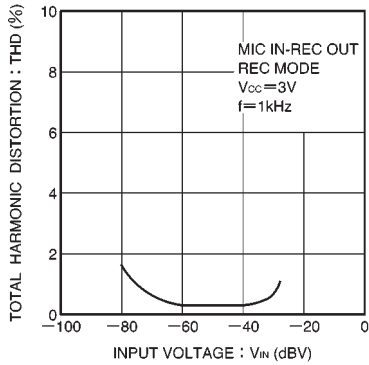

Fig. 8 Distortion vs. input voltage

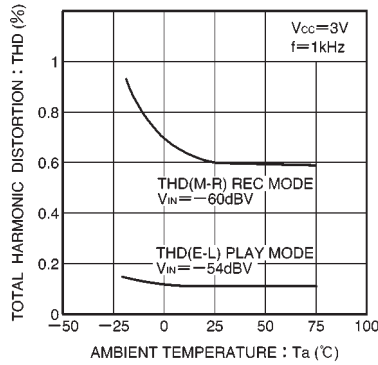

Fig. 9 Distortion vs. ambient temperature

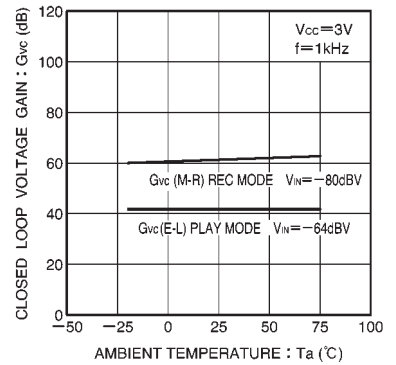

Fig. 10 Voltage gain vs. ambient temperature

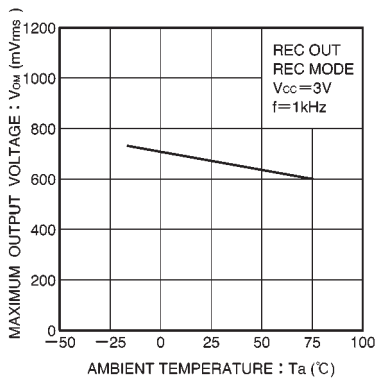

Fig. 11 Output voltage vs. ambient temperature

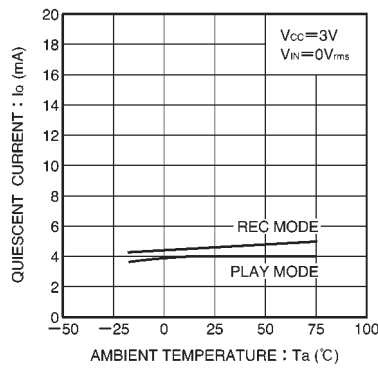

Fig. 12 Quiescent current vs. ambient temperature

● External dimensions (Units: mm)

