

---

## SPEECH - TONE/PULSE DIALER - LED INDICATOR

---

### SPEECH CIRCUIT

- 2 TO 4 WIRES CONVERSION
- PRESENT THE PROPER DC PATH FOR THE LINE CURRENT AND THE FLEXIBILITY TO ADJUST IT AND ALLOW PARALLEL PHONE OPERATION
- SYMMETRICAL HIGH IMPEDANCE MICROPHONE INPUTS SUITABLE FOR DYNAMIC, ELECTRET OR PIEZOELECTRIC TRANSDUCER
- ASYMMETRICAL EARPHONE OUTPUT SUITABLE FOR DYNAMIC TRANSDUCER
- LINE LOSS COMPENSATION FIXED INTERNALLY BY A.G.C.
- INTERNAL MUTING TO DISABLE SPEECH DURING DIALING AND EXTERNAL MUTING TO DISABLE TRANSMIT AMPLIFIER DURING CONVERSATION MODE
- LED INDICATOR EITHER FOR KEYBOARD ILLUMINATION (OR ON-LINE INDICATION) DURING DIALING AND CONVERSATION OR FOR TONE MODE INDICATION, THROUGH MU/MFI PIN

### DIALER CIRCUIT

- STORE UP TO 32 DIGITS FOR LAST NUMBER REDIAL BUFFER, LNR IS INHIBITED IF THERE ARE MORE THAN 32 DIGITS STORED
- ALLOW MIXED MODE DIALING IN PULSE MODE
- PACIFIER TONE PROVIDES AUDIBLE INDICATION OF VALID KEY PRESSED IN A BUZZER OR/AND IN THE EARPHONE
- TIMED PABX PAUSE / 10PPS PULSE RATE
- MAKE/BREAK RATIO : 40/60 (ST3917A) AND 33/67 (ST3917B)
- 4 SELECTABLE OPTIONS ON FLASH DURATION AND SOFTSWITCH INHIBITION IN ONE OF THE OPTION WITH 100ms FLASH TIMING
- 2 SELECTABLE OPTIONS : TRANSMIT MUTE TOGETHER WITH LED FOR KEYBOARD ILLUMINATION OR LED FOR TONE MODE INDICATION
- CONTINUOUS TONE FOR EACH DIGIT UNTIL KEY RELEASE
- USES INEXPENSIVE 3.579545MHz CERAMIC RESONATOR
- POWERED FROM TELEPHONE LINE, LOW OPERATING VOLTAGE FOR LONG LOOP APPLICATION

### DESCRIPTION

The device consists of the speech and the dialer functions. It provides the DC line interface circuit that terminates the telephone line, analog amplifier for speech transmission and necessary signals for either DTMF and pulse dialing. When mated with a tone ringer, a complete telephone can be produced with just two ICs. The DC line interface circuit develops its own line voltage across the device and it is adjustable by external resistor to suit different country's specification. A built-in LED driver can deliver excess line current to external LED indicator(s) during dialing and speech mode. The LED(s) can be used either for keyboard illumination purpose or for tone mode indication during softswitch and mixed mode dialing by connecting MU/MFI pin to VDD and GND or any row respectively. The LED current is limited to 17mA (typical).

The speech network provides the two to four wires interface, electronic switching between dialing and speech and automatic gain control on transmit and receive.

The dialing network buffers up to 32 digits into the LND memory that can be later redialed with a single key input. Users can store all 13 signalling keys and access several unique functions with single key entries. These functions include : Pause, Last Number Dialed (LND), Softswitch and Flash. (see Figure 1).

The FLASH key simulates a hook flash to transfer calls or to activate other special features provided by the PABX or central office.

The PAUSE key stores a timed pause in the number sequence. Redial is then delayed until an outside line can be accessed or some other activities occur before normal signalling resumes. A LND key automatically redials the last number dialed.

A dedicated pin MU/MFI is used to select the muting for transmit amplifier and lighted dial LED for keyboard illumination or a LED indicator for tone mode indication.

The SEL pin allows selection of any one of the four possible Flash duration options.

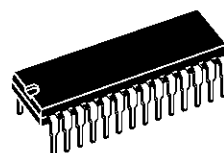

**DIP28**  
(Plastic Package)  
**ORDER CODES :**  
ST3917AN - ST3917BN

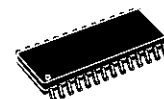

**SO28**  
(Plastic Package)  
**ORDER CODES :**  
ST3917AD - ST3917BD

**PIN CONNECTIONS**

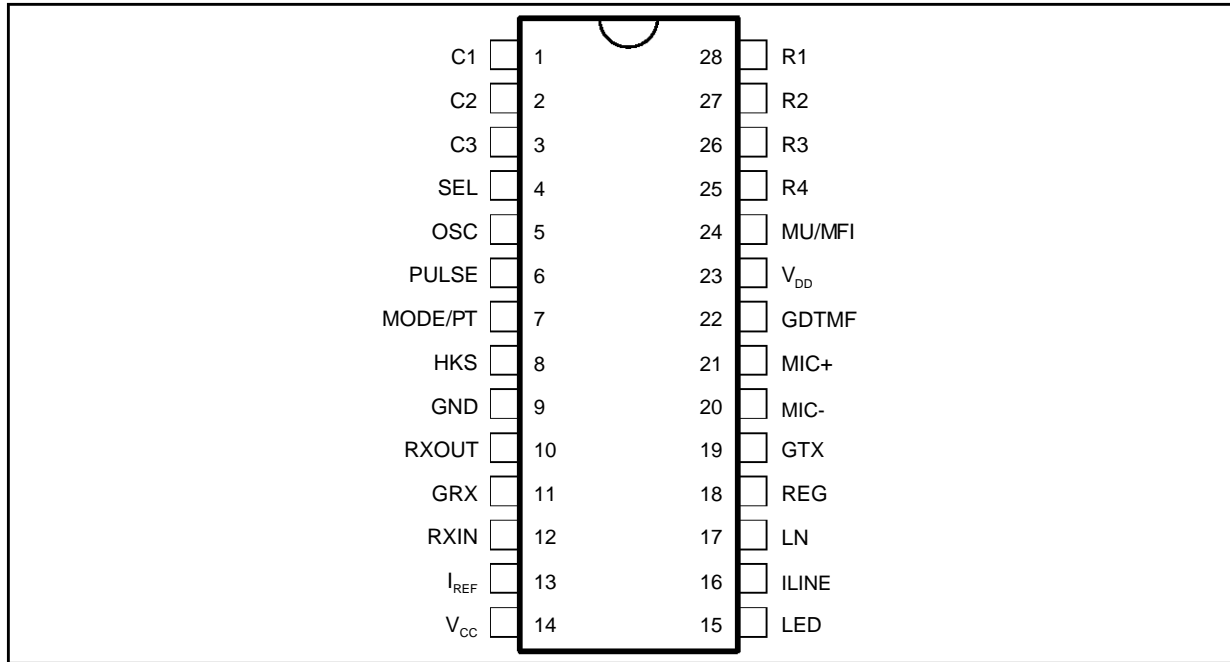

3917-01.EPS

**PIN DESCRIPTION**

**Figure 1** : Keyboard Configuration

1	2	3	Flash
4	5	6	Tone/Pulse
7	8	9	Pause
*	0	#	LND

3917-02.EPS

**C1, C2, C3, R4, R3, R2, R1**

(Keyboard inputs, Pins 1, 2, 3, 25, 26, 27, 28)

The device interfaces with either the standard 2 of 8 with negative common or the single contact (Form A) keyboard. Column 4 of the keypad is connecting to ground.

A valid keypad entry is either a single Row connected to a single Column or GND simultaneously presented to both a single Row and a single Column. In its quiescent or standby state, during normal off-hook operation, the Rows are initialized at logic level 1 (V<sub>DD</sub>) and the columns are initialized at logic level 0 (GND). Pulling any row input low enables the on chip oscillator. Keyboard scanning then begins.

Scanning consists of Rows and Columns alternately switching high through on chip pullups. After both a Row and Column keys have been detected, the debounce counter is enabled and any noise (bouncing contacts, etc) is ignored for a debounce period (TKD) of 32ms. At this time, the keyboard is sampled and if both the Row and Column information are valid, the information is buffered into the LND location.

In the tone mode, if two or more keys in the same row or if two or more keys in the same column are depressed a single tone will be output. The tone will correspond to the common row or common column for which the two keys were pushed. This feature is for test purposes, and single tone will not be redialed. Also in the tone mode, the output tone is continuous in the manual dialing as long as the key is pushed. The output tone duration follows the Table 1. When redialing in the tone mode, each DTMF output is 90ms duration, and the tone separation (inter signal delay) is 90ms.

**Table 1** : Output Tone Duration

Key Push Time, T	Tone Output
T < 32ms	No output, ignored by the device
32ms < T < 90ms + Tkd	90ms duration
T > 90 ms + Tkd	Output duration = T - tkd

**PIN DESCRIPTION** (continued)**SEL** (Input, Pin 4)

This is an option selectable pin for four Flash duration. The four options are summarised in the table 2.

For option 1, softswitch feature is inhibited. It means redialed by the LND key in pulse mode will not repeat the softswitch and subsequent digits, only pulse digits are dialed out.

**Table 2** : Options Selectable for Flash Duration

Options	SEL	Flash (ms)	Softswitch
1	V <sub>DD</sub>	100	Inhibited
2	GND	600	Enable
3	Any Row	300	Enable
4	Any Col	100	Enable

**OSC** (Input, Pin 5)

Only one pin is needed to connect the ceramic resonator to the oscillator circuit. The other end of the resonator is connected to GND. The nominal resonator frequency is 3.579545MHz and any deviation from this standard is directly reflected in the Tone output frequencies. The ceramic resonator provides the time reference for all circuit functions. A ceramic resonator with tolerance of  $\pm 0.25\%$  is recommended.

**PULSE** (Output, Pin 6)

This is an output consisting of an open drain N-channel device. During on-hook, pulse output pin is in high impedance and once off-hook, it will be pulled high by external resistor.

**MODE/PT** (Input, Pin 7)

Input (MODE). MODE determines the dialer's default operating mode. When the device is powered up or the hookswitch input is switched from on-hook (V<sub>DD</sub>) to off-hook (GND), the default determines the signalling mode. A V<sub>DD</sub> connection defaults to tone mode operation and a GND connection defaults to pulse mode operation.

When dialing in the pulse mode, a softswitch feature will allow a change to the tone mode whenever the \* or softswitch key (TONE) is depressed. Subsequent \* key inputs will cause the DTMF code for an \* to be dialed. The softswitch will only switch from pulse to tone. The phone will be in pulse mode only after returning to on-hook and back to off-hook. Redialed by the LND key will repeat the softswitch unless the softswitch redial feature is inhibited.

Output (PT). Pacifier Tone Output. In pulse mode,

all valid key entries activate the pacifier tone. In tone mode, any non DTMF entry (FLASH, PAUSE, LND, TONE) activates the pacifier tone. The pacifier tone provides audible feedback, confirming that the key has been properly entered and accepted. It is a 500Hz square wave activated upon acceptance of valid key input after the 32ms debounce time.

The square wave terminates after 75ms typically or when the valid key is no longer present. The pacifier tone signal is simultaneously sent to the earphone and the buzzer. The buzzer can be removed without affecting this function. The resistor value set on MODE/PT pin determines the level of the pacifier tone in the earphone.

**HKS** (Input, Pin 8)

This is the hookswitch input to the device. It is a CMOS input with a high pull up internal resistance and must be switched high or open for on-hook operation and low for off-hook operation. A transition on this input causes the on-chip logic to initialize, terminating any operation in progress at the time. The signalling mode defaults to the mode selected at MODE/PT pin. Figures 2, 3 and 4, 5 illustrate the timing for this pin.

**GND** (Pin 9)

GND is the negative line terminal of the device. This is the voltage reference for all specifications.

**RXOUT, GRX, RXIN** (Pins 10, 11 and 12)

The receive amplifier has one input RXIN and a non inverting output RXOUT. Amplification from RXIN to RXOUT is typically 31dB and it can be adjusted between 21dB and 41dB to suit the sensitivity of the earphone used. The amplification is proportional to the external resistor connected between GRX and RXOUT. For the hearing impaired, a specific application to offer 17dB additional gain at 3kHz is permitted.

**I<sub>REF</sub>** (Pin 13)

An external resistor of 3.6k $\Omega$  connected between IREF and GND will set the internal current level. Any change of this resistor value will influence the microphone gain, DTMF gain, earphone gain and sidetone level.

**V<sub>CC</sub>** (Pin 14)

V<sub>CC</sub> is the positive supply of the speech network. It can be stabilized by a decoupling capacitor between V<sub>CC</sub> and GND. The V<sub>CC</sub> supply voltage may also be used to supply external peripheral circuits.

**PIN DESCRIPTION** (continued)

**LED** (Output, Pin 15)

When the MU/MFI pin is connected to either V<sub>DD</sub> or GND, the LED connected to the LED pin, which functions as a keyboard illumination or off-hook indicator, will light up when the telephone is off-hook.

When the MU/MFI pin is connected to any row pins, the LED connected to LED pin functions as a tone mode indicator.

From minimum operating line current up to 20mA, I<sub>LN-ICC</sub> is sourced into the LED with a maximum current limit of 18mA. For line current more than 20mA, this sourced current is limited at 18mA (typical).

**ILINE** (Pin 16)

A recommended external resistor of 20Ω is connected between ILINE and GND. Changing this resistor value will influence the microphone gain, DTMF gain, sidetone, maximum output swing on LN and the DC characteristics, especially in the low voltage region.

**LN** (Pin 17)

LN is the positive line terminal of the device.

**REG** (Pin 18)

The internal voltage regulator has to be decoupled by a capacitor from REG to GND. The DC characteristics can be changed with an external resistor connected between LN and REG or between REG and ILINE.

**GTX, MIC-, MIC+** (Pins 19, 20, 21)

The device has a symmetrical microphone inputs. The amplification from microphone inputs to LN is 51dB at 15mA line current and it can be adjusted between 43 and 51dB. The amplification is proportional to the external resistor connected between GTX and REG.

**GDTMF** (Pin 22)

When the DTMF input is enabled, the microphone inputs and the receive amplifier input will be muted and the dialing tone will be sent on the line. The voltage amplification from GDTMF to LN is 40dB. Final output level on the LN can be adjusted via the external resistor connected between GDTMF and GND through a decoupling capacitor. A confidence tone is sent to the earphone during tone dialing. The attenuation of the confidence tone from LN to RXOUT is -32dB typically. The level of the confidence tone in the earphone can be increased by adjusting the resistor connected between GDTMF and GRX pins, the possible range is 20dB.

**V<sub>DD</sub>** (Pin 23)

V<sub>DD</sub> is the positive supply for the dialing circuit and it must meet the maximum and minimum voltage requirements.

**MU/MFI** (Input, Pin 24)

A logic low input to this pin will disable the transmit amplifier of the speech circuit. MUTE efficiency is greater than 60dB. An open circuit to this pin will enable the transmit amplifier. In this case, LED is used for keypad lighting.

A connection to any row will disable the transmit mute function and the LED connected to the LED pin is used for tone mode indication.

**Table 3** : Logic of MU/MFI Pin Indicator

MU/MFI Pin	Transmit Muting	LED at Pin 15
OPEN	Active	Lighted Dial Indicator
GND	Muted	Lighted Dial Indicator
Any Row	Not Available	Tone Mode Indicator

BLOCK DIAGRAM

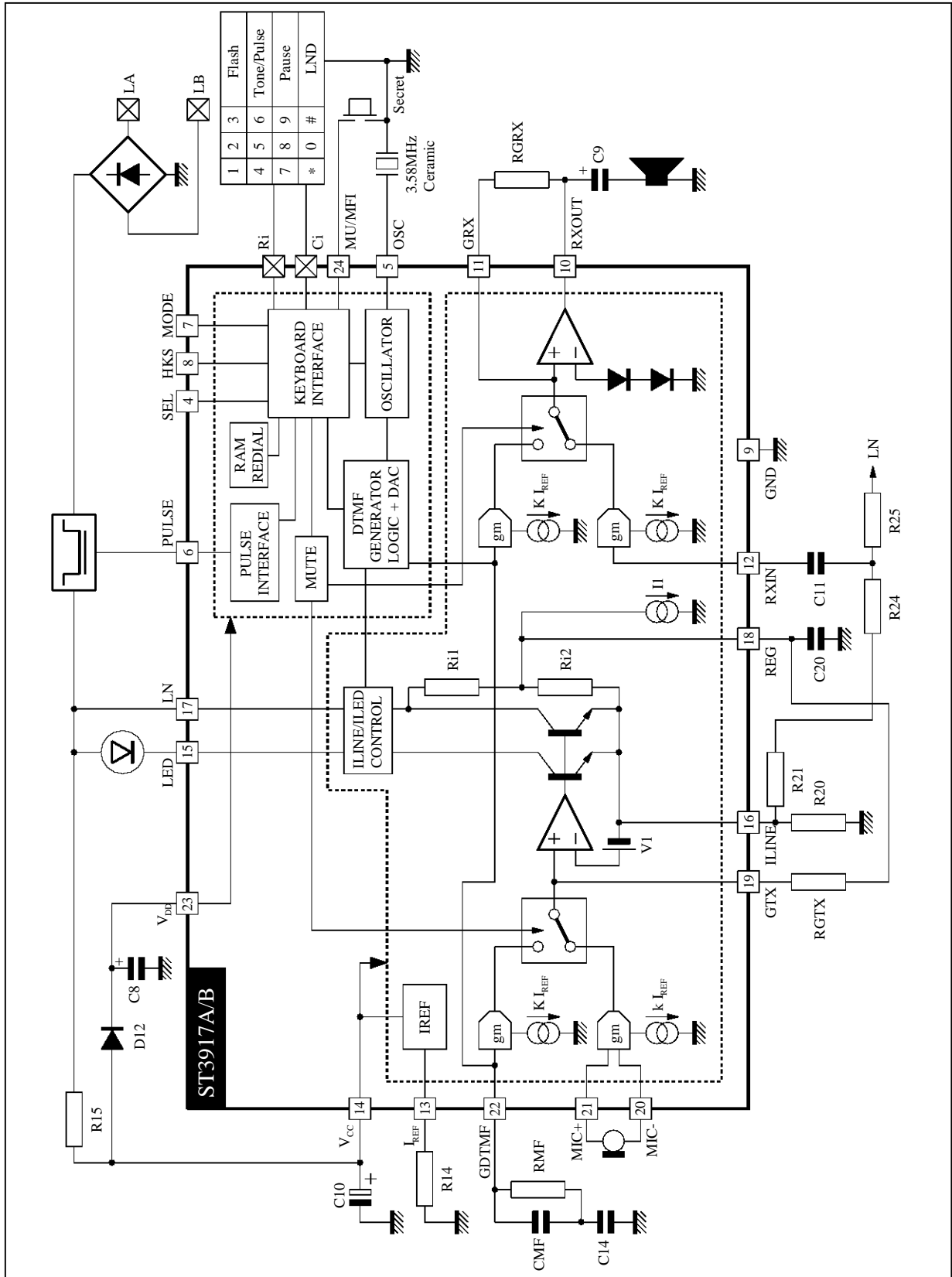

3917-03.EPS

**ABSOLUTE MAXIMUM RATINGS**

Symbol	Parameter	Value	Unit
V <sub>LN</sub>	Positive Line Voltage Continuous	12	V
I <sub>LN</sub>	Line Current	140	mA
V <sub>DD</sub>	Logic Voltage	7	V
V <sub>I</sub>	Maximum Voltage on PULSE, SEL, HKS, MODE, Ri, Ci, MU/MFI and OSC Pins	GND(-0.3) V <sub>DD</sub> (+0.3)	V
T <sub>oper</sub>	Operating Temperature	-25, +70	°C
T <sub>stg</sub>	Storage Temperature	-40, +125	°C
P <sub>tot</sub>	Total Power Dissipation	700	mW

3917-01.TBL

**ELECTRICAL CHARACTERISTICS**

(I<sub>LN</sub> = 10mA to 120mA, f = 1kHz, T<sub>amb</sub> = 25°C, V<sub>DD</sub> = 3V ; unless otherwise specified)

Symbol	Parameter	Test Conditions	Min.	Typ.	Max.	Unit
V <sub>LN</sub>	Line Voltage (see Figure 6)	I <sub>LN</sub> = 4mA	3.15	3.50	2.70	V
		I <sub>LN</sub> = 15mA				3.85
		I <sub>LN</sub> = 120mA				7.00
		I <sub>LN</sub> = 15mA, RA = 68kΩ				3.70
		I <sub>LN</sub> = 15mA, RB = 39kΩ				4.70
V <sub>DD</sub>	Logic Voltage (see Figure 6)	Tone mode	2.50		6.00	V
		Pulse mode	2.00		6.00	V
I <sub>DD</sub>	Supply Current into V <sub>DD</sub> (see Figure 6)	V <sub>DD</sub> = 3V    Tone mode Pulse mode		600 300	900 600	μA μA
I <sub>CC</sub>	Supply Current into V <sub>CC</sub> (see Figure 6)	I <sub>LN</sub> = 15mA		1.3		mA
I <sub>LED</sub>	Supply Current to LED (see Figure 6)	I <sub>LN</sub> = 10 - 20mA I <sub>LN</sub> = 20 - 120mA	10	I <sub>LN</sub> - I <sub>CC</sub>	24	mA mA
V <sub>MR</sub>	Memory Retention Voltage (see Figure 7)	V <sub>DD</sub> = 3V	1.5			V
I <sub>MR</sub>	Memory Retention Current (see Figure 7)	V <sub>DD</sub> = 3V			1	μA
I <sub>S</sub>	Off-Hook Standby Current (see Figure 6)	V <sub>DD</sub> = 3V		100	250	μA
I <sub>PL</sub>	Pulse Output Sink Current (see Figure 6)	V <sub>OUT</sub> = 0.5V	1	3		mA
I <sub>PO</sub>	Pacifier Tone Sink/Source Current (see Figure 6)	V <sub>OUT</sub> = 0.5V(Sink) V <sub>OUT</sub> = 2.5V(Source)	1.00	3.00		mA
			0.60	1.00		mA
V <sub>IL</sub>	HKS, Mode, Keyboard Inputs Low				0.3xV <sub>DD</sub>	V
V <sub>IH</sub>	HKS, Mode, Keyboard Inputs High		0.7xV <sub>DD</sub>			V
G <sub>TX</sub>	Transmit Gain (see Figure 9)	V <sub>MIC</sub> = 2mV <sub>RMS</sub> I <sub>LN</sub> = 15mA, R <sub>GTX</sub> = 68kΩ I <sub>LN</sub> = 60mA, R <sub>GTX</sub> = 68kΩ	49.5	51	52.5	dB
			43	45	47	dB
A <sub>GTX</sub>	Transmit Gain Variation (see Figure 9)	I <sub>LN</sub> = 15mA, V <sub>MIC</sub> = 2mV <sub>RMS</sub> R <sub>GTX</sub> = 43kΩ R <sub>GTX</sub> = 27kΩ	-8		0	dB
				-4		dB
				-8		dB
D <sub>TX</sub>	Transmit Distortion (see Figure 9)	I <sub>LN</sub> = 15mA, V <sub>LN</sub> = 1V <sub>RMS</sub>			2	%
N <sub>TX</sub>	Transmit Noise (see Figure 9)	I <sub>LN</sub> = 15mA, V <sub>MIC</sub> = 0V		-72		dBmp
Z <sub>MIC</sub>	Microphone Input Impedance (see Figure 8)		50	64	80	kΩ
G <sub>DTMF</sub>	DTMF Gain (see Figure 10)	R <sub>DTMF</sub> = 2.25kΩ, C <sub>DTMF</sub> = 22nF	37	39	41	dB
C <sub>DTMF</sub>	DTMF Confidence Tone Attenuation (see Figure 10)		-34	-31.5	-29	dB
V <sub>DTMF</sub>	DTMF level on the line (see Figure 10) High Frequency Group Low Frequency Group	R <sub>DTMF</sub> = 2.25kΩ, C <sub>DTMF</sub> = 22nF	-8	-6	-4	dBm
			-10	-8	-6	dBm
P <sub>EI</sub>	Pre-emphasis (see Figure 10)		1	2	3	dB
DIS	DTMF Output Distortion (see Figure 10)			5	8	%

3917-02.TBL

**ELECTRICAL CHARACTERISTICS** (continued)

( $I_{LN} = 10\text{mA}$  to  $120\text{mA}$ ,  $f = 1\text{kHz}$ ,  $T_{amb} = 25^\circ\text{C}$ ,  $V_{DD} = 3\text{V}$ ; unless otherwise specified)

Symbol	Parameter	Test Conditions	Min.	Typ.	Max.	Unit
Z <sub>DTMF</sub>	DTMF Attenuation Pin Impedance		25	32	39	kΩ
G <sub>RX</sub>	Receive gain (see Figure 11)	V <sub>INP</sub> = 4mV <sub>RMS</sub> , R <sub>E</sub> = 300Ω, R <sub>G<sub>RX</sub></sub> = 100kΩ I <sub>LN</sub> = 15mA I <sub>LN</sub> = 60mA	29.5 23.0	31.0 25.0	32.5 27.0	dB dB
A <sub>GRX</sub>	Receive Gain Variation (see Figure 11)	V <sub>INP</sub> = 4mV <sub>RMS</sub> , R <sub>E</sub> = 300Ω, I <sub>LN</sub> = 15mA R <sub>G<sub>RX</sub></sub> = 10KΩ R <sub>G<sub>RX</sub></sub> = 300kΩ	-20	-20 +10	10	dB dB dB
D <sub>RX</sub>	Receive Distortion (see Figure 11)	I <sub>LN</sub> = 15mA, R <sub>G<sub>RX</sub></sub> = 100kΩ R <sub>E</sub> = 150Ω, V <sub>EAR</sub> = 0.25V <sub>RMS</sub> R <sub>E</sub> = 300Ω, V <sub>EAR</sub> = 0.45V <sub>RMS</sub> R <sub>E</sub> = 450Ω, V <sub>EAR</sub> = 0.55V <sub>RMS</sub>			2 2 2	% % %
N <sub>RX</sub>	Receive Noise (see Figure 11)	I <sub>LN</sub> = 15mA, R <sub>E</sub> = 300Ω R <sub>G<sub>RX</sub></sub> = 100kΩ, V <sub>INP</sub> = 0V		200		μV
Z <sub>OUT</sub>	Receive Output Impedance (see Figure 11)	I <sub>LN</sub> = 15mA		35		Ω
V <sub>PT</sub>	Pacifier Tone Level on Earphone (see Figure 11)	I <sub>LN</sub> = 15mA R <sub>P</sub> = ∞ R <sub>P</sub> = 430kΩ		60 600		mV <sub>RMS</sub> mV <sub>RMS</sub>
TKD FKS KRU KRD	Keyboard Interface Keypad Debounce Time Keypad Scan Frequency Keypad Pullup Resistance Keypad Pulldown Resistance	See Figures 4 and 5		32 250 100 500		ms Hz kΩ Ω
TRIS TR TPSD TISD TDUR	Tone Mode Tone Output Rise Time Tone Signalling Rate Presignal Delay Intersignal Delay Tone Output Duration	See Figures 2 and 3	40	5.55 90 90	5	ms 1/sec ms ms ms
TPT FPT PR TB TM IDP PDP	Pulse Mode Pacifier Tone Duration Pacifier Tone Frequency Pulse Rate Break Time : ST3917A ST3917B Make Time : ST3917A ST3917B Interdigital Pause Predigital Pause : ST3917A ST3917B	See Figures 4 and 5		75 500 10 60 67 40 33 820 50 43		ms Hz PPS ms ms ms ms ms ms ms

3917-02.TBL

**Option Selectable**

Symbol	Parameter	Option 1 SEL = V <sub>DD</sub>	Option 2 SEL = GND	Option 3 SEL = ROW	Option 4 SEL = COL	Unit
t <sub>FLASH</sub>	Timed Hook Flash (see Figures 2 and 3)	100	600	300	100	ms

- Notes :**
- All inputs unloaded. Quiescent mode (oscillator off).
  - Pulse output sink current for V<sub>OUT</sub> = 0.5V at V<sub>DD</sub> = 3V.
  - Pacifier tone sink current for V<sub>OUT</sub> = 0.5V, source current for V<sub>OUT</sub> = 2.5V at V<sub>DD</sub> = 3V.
  - Memory retention voltage is the point where memory is guaranteed but circuit operation is not. Proper memory retention is guaranteed if either the minimum I<sub>MR</sub> is provided or the minimum V<sub>MR</sub>. The design does not have to provide both the minimum current and voltage.
  - Option 1 is with softswitch inhibition.

**DEVICE OPERATION**

During on-hook all keypad inputs are high impedance internally and it requires very low current for memory retention. At anytime, row inputs are initialized at logic level 1 and column inputs are initialized at logic level 0 at off-hook. The circuit verifies that a valid key has been entered by alternately scanning the Row and Column inputs. If the input is still valid following 32ms of debounce, the digit is stored into memory, and dialing begins after a pre-signal delay of approximately 40ms measured from the initial key closure. Output tone duration is shown in Table 1.

The device allows manual dialing of an indefinite number of digits, but if more than 32 digits are dialed, LND will be inhibited.

**Table 4 : DTMF Output Frequencies (Hz)**

Key Input	Std Frequency	Output Frequency	% in Deviation
Row 1	697	699.1	+0.31
Row 2	770	766.2	-0.49
Row 3	852	847.4	-0.54
Row 4	941	948	+0.74
Column 1	1209	1215.9	+0.57
Column 2	1336	1331.7	-0.32
Column 3	1477	1471.9	-0.35

**Normal Dialing**

***D D D ...***

Normal dialing is straight forward, all keyboard entries will be stored in the buffer and signalled in succession.

**Hook Flash**

***D Flash D ...***

Hook flash may be entered into the dialed sequence at any point by keying in the function key, FLASH. When a FLASH key is pressed, no further key inputs will be accepted until the hookflash function has been dialed. The key input following a FLASH will be stored as the initial digit of the new number (overwriting the number dialed before the FLASH) unless it is another FLASH. FLASH key pressed immediately after hook-switch or LND will not clear the LND buffer unless digits are entered following the FLASH key.

***Flash***

LND not cleared

***LND Flash***

LND not cleared

***LND Flash D1 D2***

LND buffer will contain D1, D2

**Last Number Dialed**

***Off-Hook LND***

Last number redialing is accomplished by entering the LND key at off-hook or after the FLASH key, the subsequent LND keys pressed will be ignored.

Sequence	Digit Emitted
OFF-HOOK, D1, D2, ON-HOOK	D1, D2
OFF-HOOK, LND, LND, ON-HOOK	D1, D2
OFF-HOOK, D3, D4, LND, ON-HOOK	D3, D4
OFF-HOOK, LND, ON-HOOK	D3, D4

**Last Number Dialed Inhibition**

Last number redialing by LND key is inhibited if there are more than 32 digits stored.

**Last Number Dialed Cascading**

Digits dial after the LND will cascade into the LND buffer for the next redialing. In cascade operation, the keyboard is inhibited upon pressing the LND key, the LND output must be completed before acceptance of any key entry.

Sequence	Digit Emitted
OFF-HOOK, D1, D2, ON-HOOK	D1, D2
OFF-HOOK, LND, D3, D4, ON-HOOK	D1, D2, D3, D4
OFF-HOOK, LND, ON-HOOK	D1, D2, D3, D4

**Pause**

***Off-Hook D Pause D ...***

A pause may be entered into the dialed sequence at any point by keying in the special function key, PAUSE. Pause inserts a 3.1 seconds (Tone mode) or 3.4 seconds (Pulse mode) delay into the dialing sequence. The total delay, including predigit and post digit pauses as shown in Table 5.

**Table 5 : Special Function Delays**

Function	First / Auto	Delay (second)	
		Pulse	Tone
SOFT-SWITCH	First	0.2	
	Auto	1	
PAUSE	First	2.6	3.0
	Auto	3.4	3.1

Each delay shown in Table 5 represents the time required from the time the special function key is depressed until a new digit is dialed.

The time is considered "FIRST" key if all previous inputs have been completely dialed. The time is considered "AUTO" if in redial, or if previous digits dialing is still in progress.



**DEVICE OPERATION** (continued)

**Led Indicator / Tone Mode Indication**

When the MU/MFI (Pin 24) is connected to any row of the keypad input, the LED connected to Pin 15 (LED) becomes a Tone mode indicator.

The LED indicator is used in the following conditions :

- At Tone mode, LED will light up at off-hook. The LED will turn off only when the telephone goes on-hook.

**Example :** Tone mode

OFF-HOOK (LED turns on) <TONE> D1, D2, D3  
 ON-HOOK (LED turns off)  
 OFF-HOOK (LED turns on) <TONE> LND  
 ON-HOOK (LED turns off)

- At Pulse mode after off-hook, LED is off during pulse dialing. When dialing is followed by the "\*" or "TONE" softswitch key depressed, the LED will light up immediately at the softswitch after pulse dialing is completed to indicate the signalling mode change from pulse to tone. After returning to on-hook and back to off-hook, the device will be in pulse mode and then LED is turned off. Redialing from LND memory buffer will repeat the softswitch, i.e. mixed mode redialing,

the LED will light up to indicate the switch to tone mode or tone dialing. The LED will turn off only when the telephone goes on-hook or is reset by the Flash key

**Examples :** Pulse mode

- a) OFF-HOOK (LED is off) <Pulse> D1, D2 (LED remains off), "\*" <Tone> (LED turns on), D3, D4  
 ON-HOOK or Flash (LED turns off)
- b) OFF-HOOK (LED is off) <Pulse> LND <Pulse> D1, D2 (LED remains off), "\*" <Tone> (LED turns on) D3, D4,  
 ON-HOOK or Flash (LED turns off)

- At Pulse mode, after off-hook, LED is off during pulse dialing. When switching the Tone/Pulse mechanical switch to Tone mode, LED will turn on.

**Example :** Pulse mode

OFF-HOOK (LED is off) <Pulse> D1, D2 Switch "Tone/Pulse" mechanical switch to Tone mode (LED turns on) <Tone> D3, D4,  
 ON-HOOK (LED turns off)

The function of the LED for Tone mode indicator is described in the timing waveform in Figures 2, 3, 4 and 5.

**Figure 2 :** Tone Mode Timing with Lighted Dial LED (Pin 24 to V<sub>DD</sub> or GND)

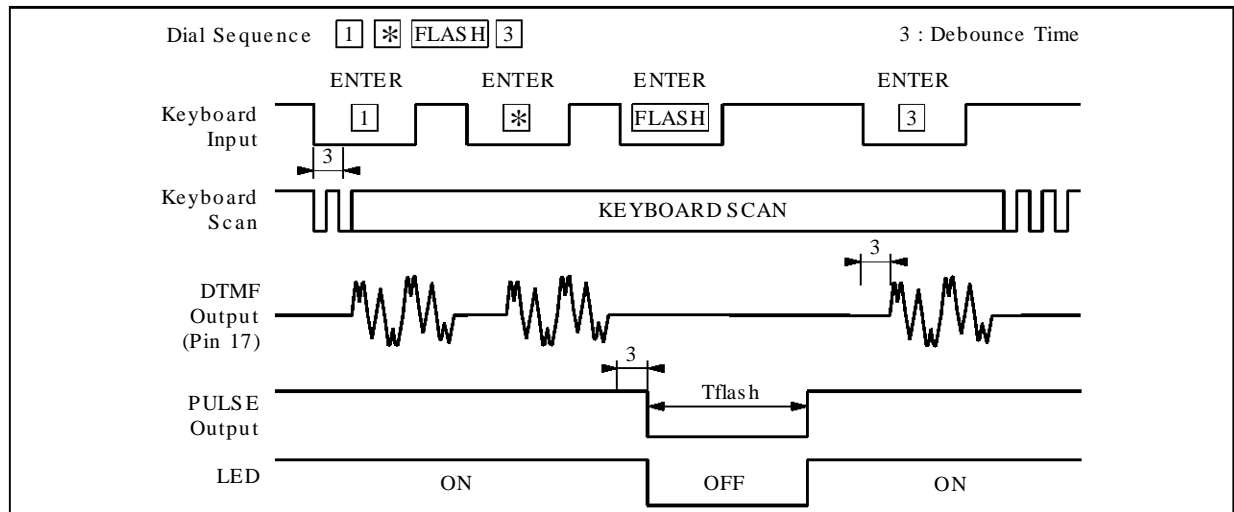

3917-04.EPS

Figure 3 : Tone Mode Timing with Tone Indicator (Pin 24 to any row)

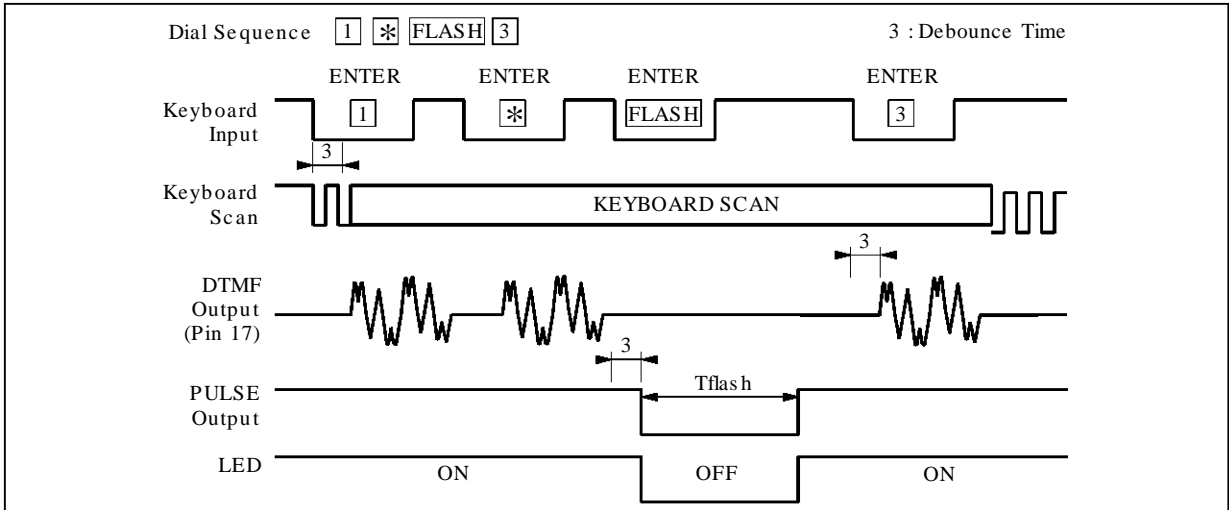

3917-06.EPS

Figure 4 : Pulse Mode Timing with Lighted Dial LED (Pin 24 to V<sub>DD</sub> or GND)

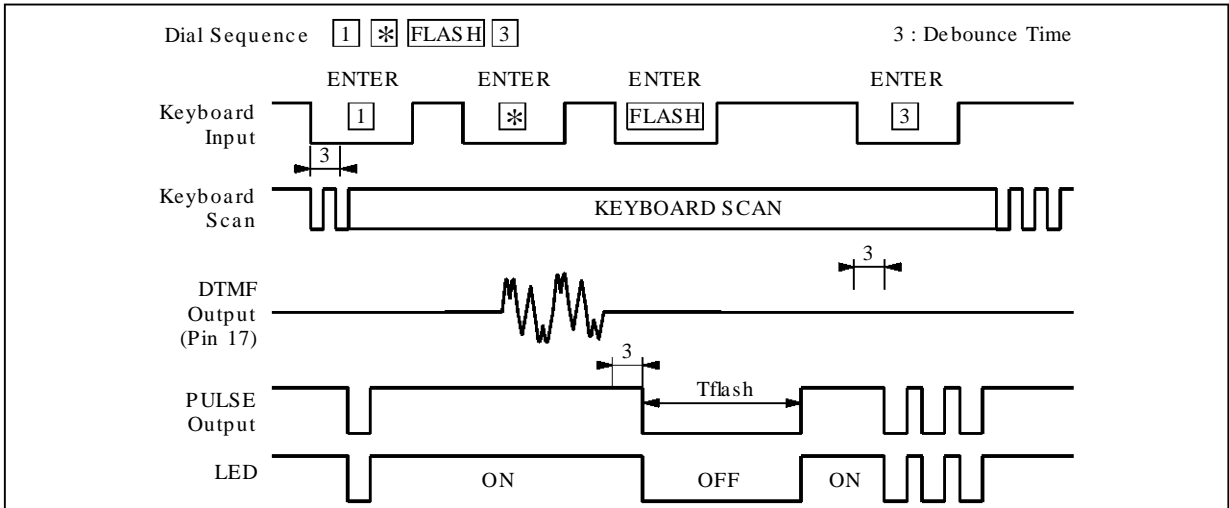

3917-06.EPS

Figure 5 : Pulse Mode Timing with Tone Indicator Using "\*" or "Tone" Key

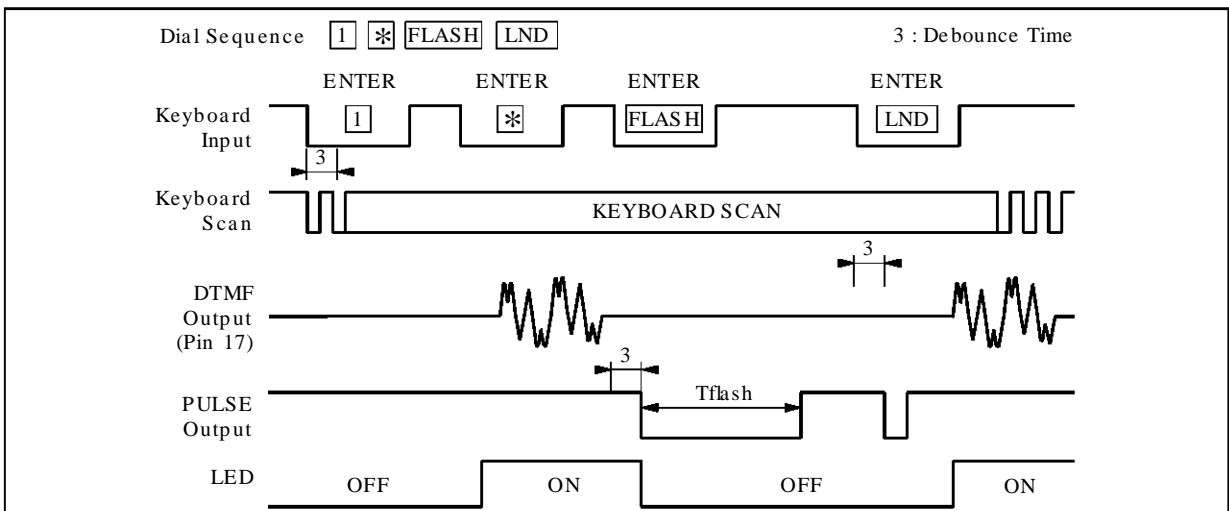

3917-07.EPS

Figure 6 : Test

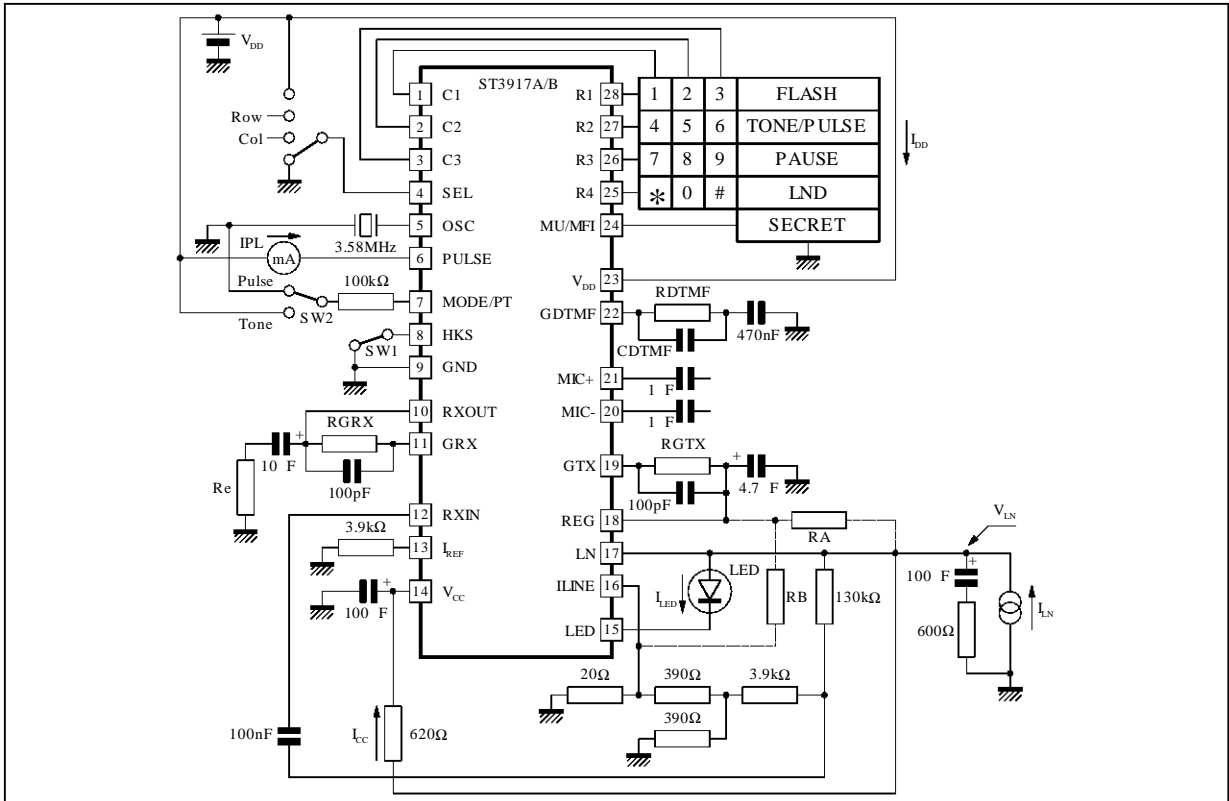

3917-08.EPS

Figure 7 : Test

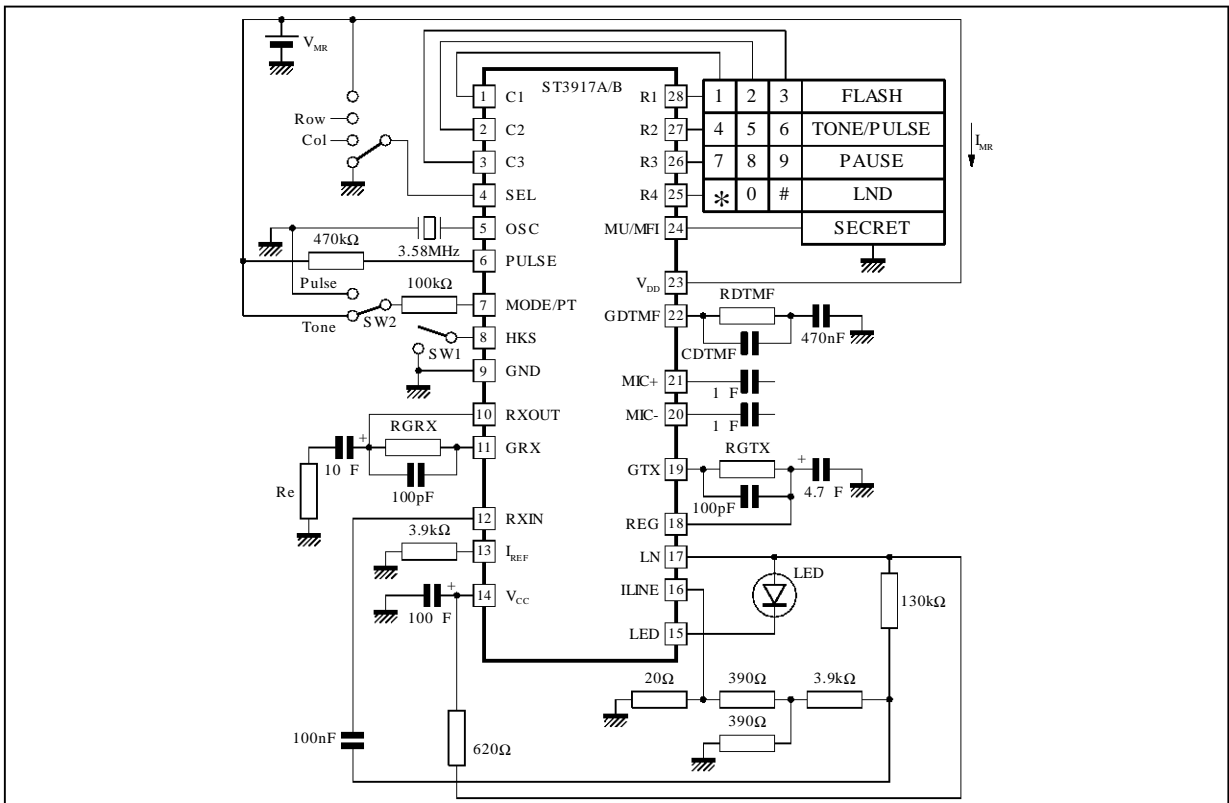

3917-09.EPS

Figure 8 : Test

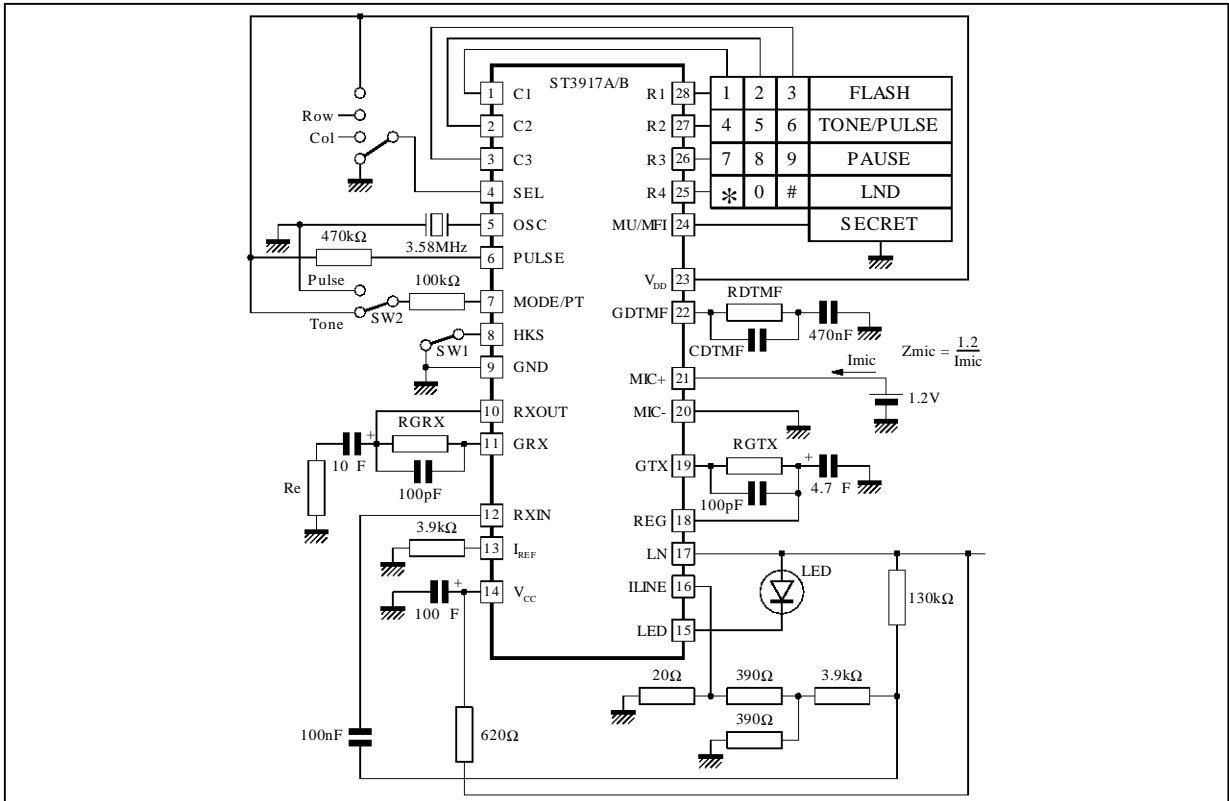

3917-10.EPS

Figure 9 : Test

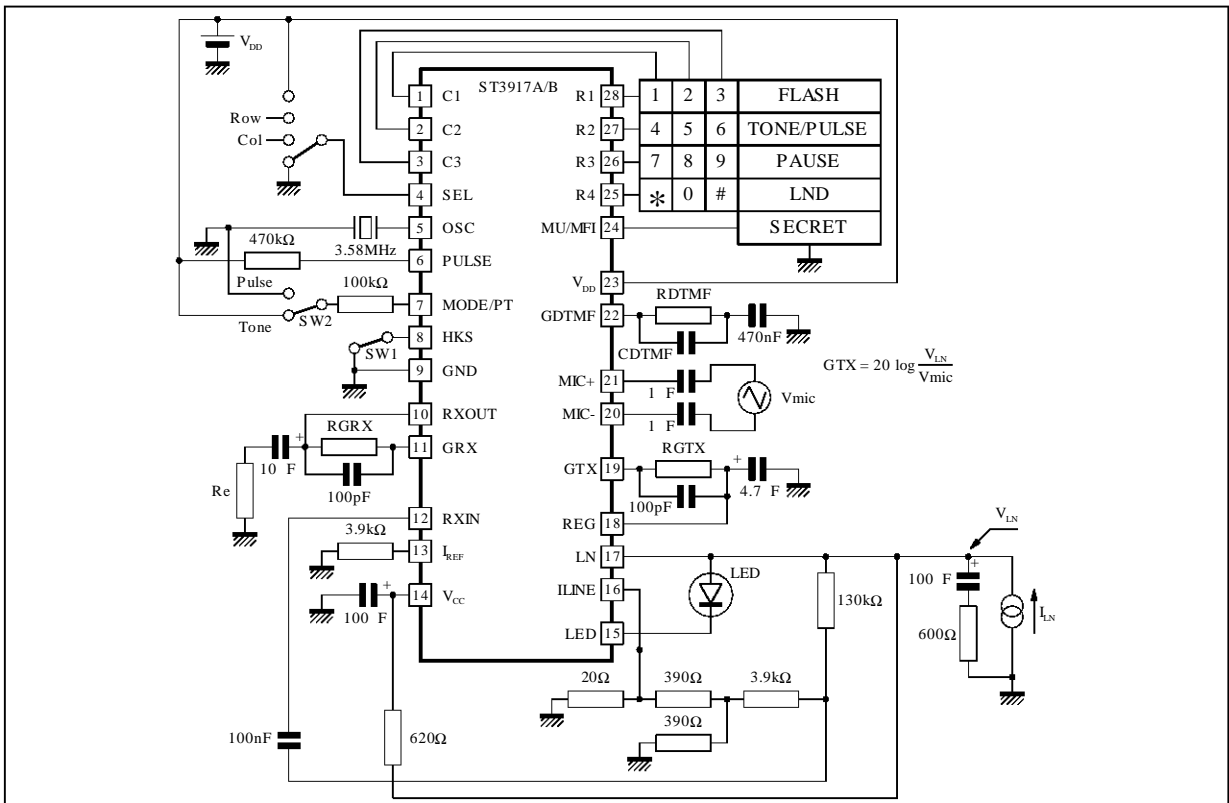

3917-11.EPS

Figure 10 : Test

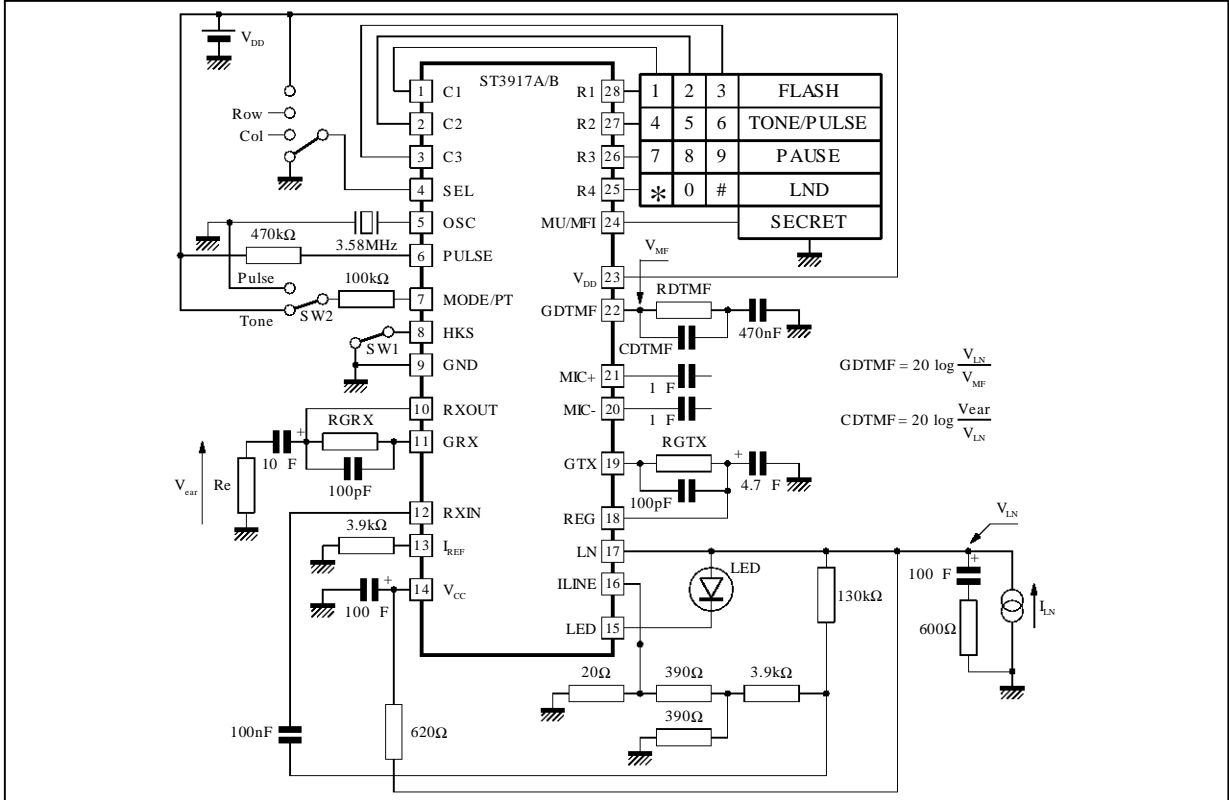

3917-12.EPS

Figure 11 : Test

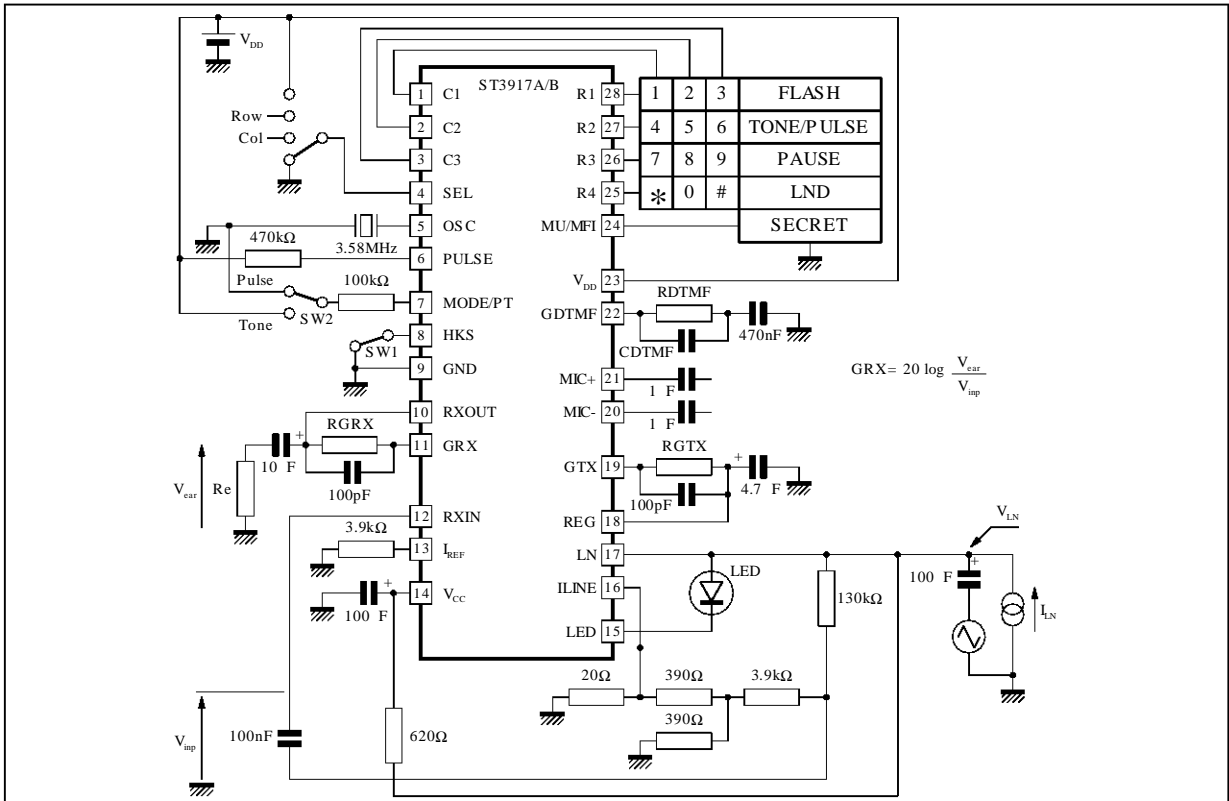

3917-13.EPS

TYPICAL APPLICATION

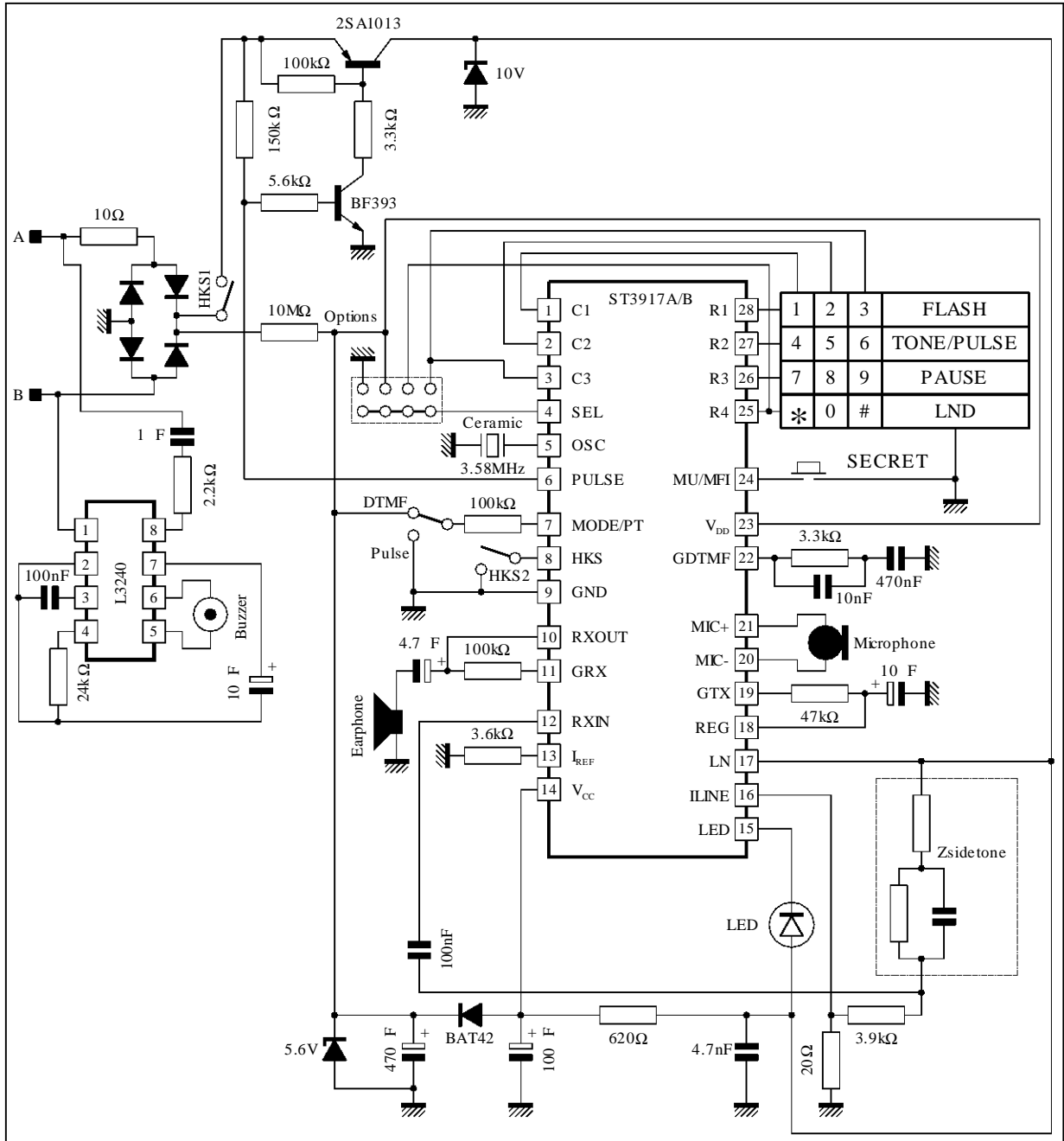

3917-14.EPS

**PACKAGE MECHANICAL DATA**  
28 PINS - PLASTIC PACKAGE

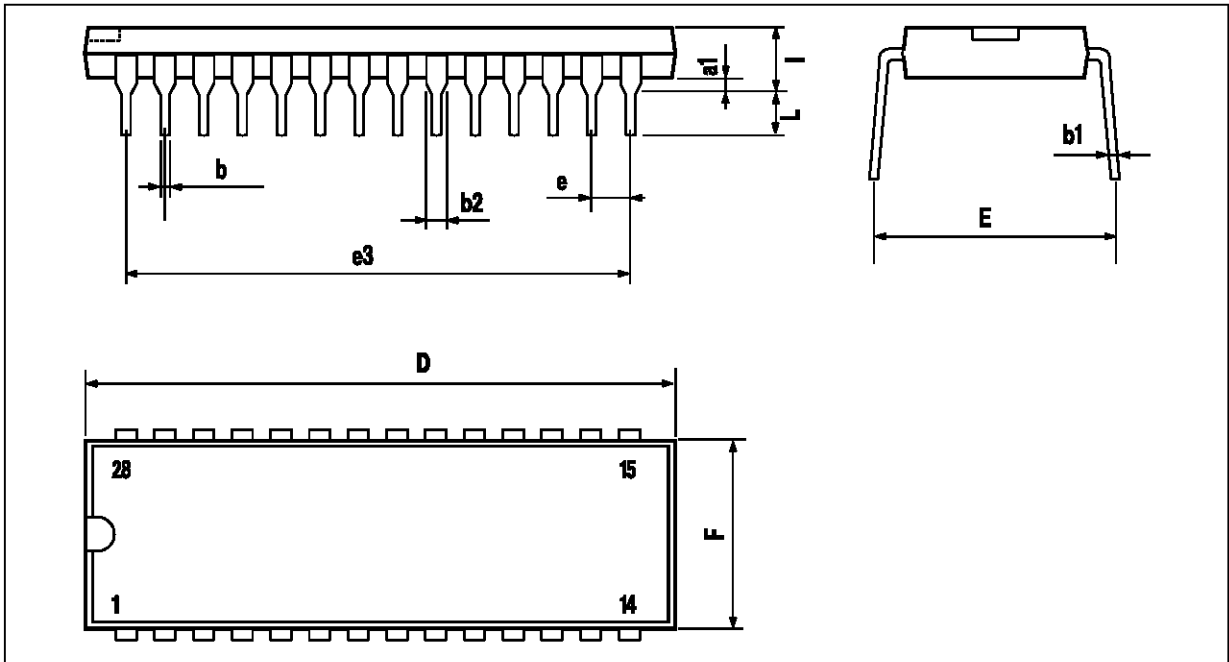

PM-DIP28.EPS

Dimensions	Millimeters			Inches		
	Min.	Typ.	Max.	Min.	Typ.	Max.
a1		0.63			0.025	
b		0.45			0.018	
b1	0.23		0.31	0.009		0.012
b2		1.27			0.050	
D			37.4			1.470
E	15.2		16.68	0.598		0.657
e		2.54			0.100	
e3		33.02			1.300	
F			14.1			0.555
l		4.445			0.175	
L		3.3			0.130	

DIP28.TBL

# ST3917A - ST3917B

## PACKAGE MECHANICAL DATA 28 PINS - PLASTIC PACKAGE

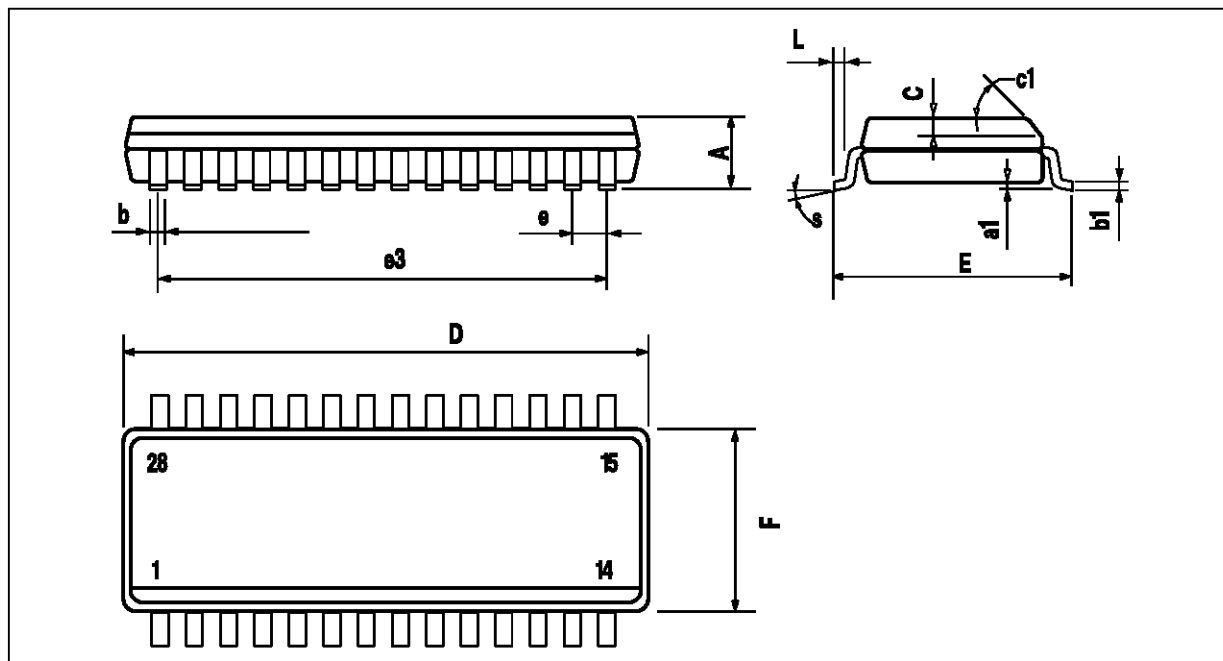

PM-SO28LEFS

Dimensions	Millimeters			Inches		
	Min.	Typ.	Max.	Min.	Typ.	Max.
A			2.65			0.104
a1	0.1		0.3	0.004		0.012
b	0.35		0.49	0.014		0.019
b1	0.23		0.32	0.009		0.013
C		0.5			0.020	
c1	45° (Typ.)					
D	17.7		18.1	0.697		0.713
E	10		10.65	0.394		0.419
e		1.27			0.050	
e3		16.51			0.65	
F	7.4		7.6	0.291		0.299
L	0.4		1.27	0.016		0.050
S	8° (Max.)					

SO28.TBL

Information furnished is believed to be accurate and reliable. However, SGS-THOMSON Microelectronics assumes no responsibility for the consequences of use of such information nor for any infringement of patents or other rights of third parties which may result from its use. No licence is granted by implication or otherwise under any patent or patent rights of SGS-THOMSON Microelectronics. Specifications mentioned in this publication are subject to change without notice. This publication supersedes and replaces all information previously supplied. SGS-THOMSON Microelectronics products are not authorized for use as critical components in life support devices or systems without express written approval of SGS-THOMSON Microelectronics.

© 1996 SGS-THOMSON Microelectronics - All Rights Reserved

Purchase of I<sup>2</sup>C Components of SGS-THOMSON Microelectronics, conveys a license under the Philips I<sup>2</sup>C Patent. Rights to use these components in a I<sup>2</sup>C system, is granted provided that the system conforms to the I<sup>2</sup>C Standard Specifications as defined by Philips.

SGS-THOMSON Microelectronics GROUP OF COMPANIES

Australia - Brazil - Canada - China - France - Germany - Hong Kong - Italy - Japan - Korea - Malaysia - Malta - Morocco  
The Netherlands - Singapore - Spain - Sweden - Switzerland - Taiwan - Thailand - United Kingdom - U.S.A.