

SN54ALS1008A, SN54AS1008A, SN74ALS1008A, SN74AS1008A QUADRUPLE 2-INPUT POSITIVE-AND BUFFERS/DRIVERS

SDAS071A – D2661, DECEMBER 1982 – REVISED MAY 1986

- 'ALS1008A is a Buffer Version of 'ALS08
- 'AS1008A is a Driver Version of 'AS08
- 'AS1008A Offers High Capacitive Drive Capability
- Package Options include Plastic Small Outline Packages, Ceramic Chip Carriers, and Standard Plastic and Ceramic 300-mil DIPs
- Dependable Texas Instruments Quality and Reliability

description

These devices contain four independent 2-input AND buffers/drivers. They perform the Boolean functions $Y = A \cdot B$ or $Y = \overline{A} + \overline{B}$ in positive logic.

The SN54ALS1008A and SN54AS1008A are characterized for operation over the full military temperature range of -55°C to 125°C . The SN74ALS1008A and SN74AS1008A are characterized for operation from 0°C to 70°C .

FUNCTION TABLE
(each gate)

INPUTS		OUTPUT
A	B	Y
H	H	H
L	X	L
X	L	L

logic symbol†

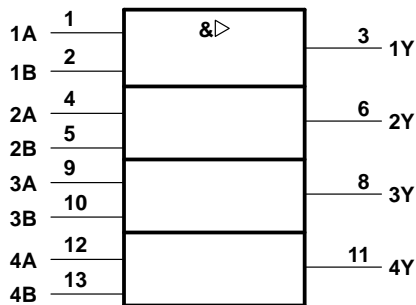

† This symbol is in accordance with ANSI/IEEE Std 91-1984 and IEC Publication 617-12.

Pin numbers shown are for D, J, and N packages.

SN54ALS1008A, SN54AS1008A . . . J PACKAGE
SN74ALS1008A, SN74AS1008A . . . D OR N PACKAGE
(TOP VIEW)

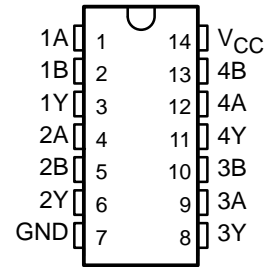

SN54ALS1008A, SN54AS1008A . . . FK PACKAGE
(TOP VIEW)

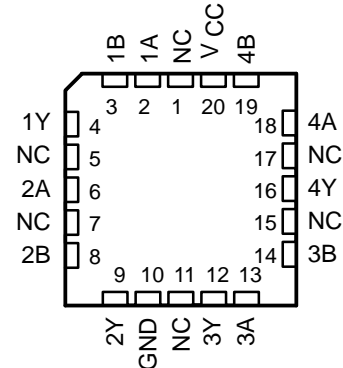

NC – No internal connection

logic diagram (positive logic)

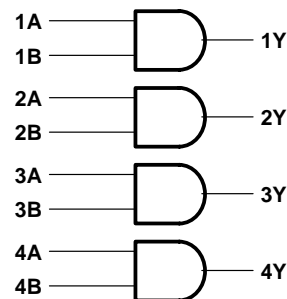

SN54ALS1008A, SN74ALS1008A QUADRUPLE 2-INPUT POSITIVE-AND BUFFERS

SDAS071A – D2661, DECEMBER 1982 – REVISED MAY 1986

absolute maximum ratings over operating free-air temperature range (unless otherwise noted)

Supply voltage, V_{CC}	7 V
Input voltage	7 V
Operating free-air temperature range:	
SN54ALS1008A	–55°C to 125°C
SN74ALS1008A	0°C to 70°C
Storage temperature range	–65°C to 150°C

recommended operating conditions

		SN54ALS1008A			SN74ALS1008A			UNIT
		MIN	NOM	MAX	MIN	NOM	MAX	
V_{CC}	Supply voltage	4.5	5	5.5	4.5	5	5.5	V
V_{IH}	High-level input voltage	2			2			V
V_{IL}	Low-level input voltage			0.7			0.8	V
I_{OH}	High-level output current			–1			–2.6	mA
I_{OL}	Low-level output current			12			24	mA
T_A	Operating free-air temperature	–55		125	0		70	°C

electrical characteristics over recommended operating free-air temperature range (unless otherwise noted)

PARAMETER	TEST CONDITIONS	SN54ALS1008A			SN74ALS1008A			UNIT
		MIN	TYP†	MAX	MIN	TYP†	MAX	
V_{IK}	$V_{CC} = 4.5\text{ V}$, $I_I = -18\text{ mA}$			–1.5			–1.5	V
V_{OH}	$V_{CC} = 4.5\text{ V to } 5.5\text{ V}$, $I_{OH} = -0.4\text{ mA}$	$V_{CC}-2$			$V_{CC}-2$			V
	$V_{CC} = 4.5\text{ V}$, $I_{OH} = -1\text{ mA}$	2.4	3.3		2.4	3.2		
	$V_{CC} = 4.5\text{ V}$, $I_{OH} = -2.6\text{ mA}$							
V_{OL}	$V_{CC} = 4.5\text{ V}$, $I_{OL} = 12\text{ mA}$		0.25	0.4				V
	$V_{CC} = 4.5\text{ V}$, $I_{OL} = 24\text{ mA}$				0.35	0.5		
I_I	$V_{CC} = 5.5\text{ V}$, $V_I = 7\text{ V}$			0.1			0.1	mA
I_{IH}	$V_{CC} = 5.5\text{ V}$, $V_I = 2.7\text{ V}$			20			20	μA
I_{IL}	$V_{CC} = 5.5\text{ V}$, $V_I = 0.4\text{ V}$			–0.1			–0.1	mA
I_{O}^{\ddagger}	$V_{CC} = 5.5\text{ V}$, $V_O = 2.25\text{ V}$	–30		–112	–30		–112	mA
I_{CCH}	$V_{CC} = 5.5\text{ V}$, $V_I = 4.5\text{ V}$		1.8	3		1.8	3	mA
I_{CCL}	$V_{CC} = 5.5\text{ V}$, $V_I = 0$		5.7	9.3		5.7	9.3	mA

† All typical values are at $V_{CC} = 5\text{ V}$, $T_A = 25^\circ\text{C}$.

‡ The output conditions have been chosen to produce a current that closely approaches the true short-circuit output current, I_{OS} .

switching characteristics (see Note 1)

PARAMETER	FROM (INPUT)	TO (OUTPUT)	$V_{CC} = 4.5\text{ V to } 5.5\text{ V}$, $C_L = 50\text{ pF}$, $R_L = 500\ \Omega$, $T_A = \text{MIN to MAX}$				UNIT
			SN54ALS1008A		SN74ALS1008A		
			MIN	MAX	MIN	MAX	
t_{PLH}	A or B	Y	2	11	2	9	ns
t_{PHL}			3	11	3	9	

NOTE 1: Load circuit and voltage waveforms are shown in Section 1.



SN54AS1008A, SN74AS1008A QUADRUPLE 2-INPUT POSITIVE-AND DRIVERS

SDAS071A – D2661, DECEMBER 1982 – REVISED MAY 1986

absolute maximum ratings over operating free-air temperature range (unless otherwise noted)

Supply voltage, V_{CC}	7 V
Input voltage	7 V
Operating free-air temperature range: SN54AS1008A	–55°C to 125°C
SN74AS1008A	0°C to 70°C
Storage temperature range	–65°C to 150°C

recommended operating conditions

		SN54AS1008A			SN74AS1008A			UNIT
		MIN	NOM	MAX	MIN	NOM	MAX	
V_{CC}	Supply voltage	4.5	5	5.5	4.5	5	5.5	V
V_{IH}	High-level input voltage	2			2			V
V_{IL}	Low-level input voltage			0.8			0.8	V
I_{OH}	High-level output current			–40			–48	mA
I_{OL}	Low-level output current			40			48	mA
T_A	Operating free-air temperature	–55		125	0		70	°C

electrical characteristics over recommended operating free-air temperature range (unless otherwise noted)

PARAMETER	TEST CONDITIONS	SN54AS1008A			SN74AS1008A			UNIT
		MIN	TYP†	MAX	MIN	TYP†	MAX	
V_{IK}	$V_{CC} = 4.5\text{ V}$, $I_I = -18\text{ mA}$			–1.2			–1.2	V
V_{OH}	$V_{CC} = 4.5\text{ V to } 5.5\text{ V}$, $I_{OH} = -2\text{ mA}$	$V_{CC}-2$			$V_{CC}-2$			V
	$V_{CC} = 4.5\text{ V}$, $I_{OH} = -3\text{ mA}$	2.4	3.2		2.4	3.2		
	$V_{CC} = 4.5\text{ V}$, $I_{OH} = -40\text{ mA}$	2						
	$V_{CC} = 4.5\text{ V}$, $I_{OH} = -48\text{ mA}$				2			
V_{OL}	$V_{CC} = 4.5\text{ V}$, $I_{OL} = 40\text{ mA}$		0.25	0.5				V
	$V_{CC} = 4.5\text{ V}$, $I_{OL} = 48\text{ mA}$					0.35	0.5	
I_I	$V_{CC} = 5.5\text{ V}$, $V_I = 7\text{ V}$			0.1			0.1	mA
I_{IH}	$V_{CC} = 5.5\text{ V}$, $V_I = 2.7\text{ V}$			20			20	μA
I_{IL}	$V_{CC} = 5.5\text{ V}$, $V_I = 0.4\text{ V}$			–0.5			–0.5	mA
I_{O}^{\ddagger}	$V_{CC} = 5.5\text{ V}$, $V_O = 2.25\text{ V}$	–50		–200	–50		–200	mA
I_{CCH}	$V_{CC} = 5.5\text{ V}$, $V_I = 4.5\text{ V}$		5.6	9.5		5.6	9.5	mA
I_{CCL}	$V_{CC} = 5.5\text{ V}$, $V_I = 0$		13.5	22		13.5	22	mA

† All typical values are at $V_{CC} = 5\text{ V}$, $T_A = 25^\circ\text{C}$.

‡ The output conditions have been chosen to produce a current that closely approaches the true short-circuit output current, I_{OS} .

switching characteristics (see Note 1)

PARAMETER	FROM (INPUT)	TO (OUTPUT)	$V_{CC} = 4.5\text{ V to } 5.5\text{ V}$, $C_L = 50\text{ pF}$, $R_L = 500\ \Omega$, $T_A = \text{MIN to MAX}$				UNIT
			SN54AS1008A		SN74AS1008A		
			MIN	MAX	MIN	MAX	
t_{PLH}	A or B	Y	1	6.5	1	6	ns
t_{PHL}			1	6.5	1	6	

NOTE 1: Load circuit and voltage waveforms are shown in Section 1.



IMPORTANT NOTICE

Texas Instruments (TI) reserves the right to make changes to its products or to discontinue any semiconductor product or service without notice, and advises its customers to obtain the latest version of relevant information to verify, before placing orders, that the information being relied on is current.

TI warrants performance of its semiconductor products and related software to the specifications applicable at the time of sale in accordance with TI's standard warranty. Testing and other quality control techniques are utilized to the extent TI deems necessary to support this warranty. Specific testing of all parameters of each device is not necessarily performed, except those mandated by government requirements.

Certain applications using semiconductor products may involve potential risks of death, personal injury, or severe property or environmental damage ("Critical Applications").

TI SEMICONDUCTOR PRODUCTS ARE NOT DESIGNED, INTENDED, AUTHORIZED, OR WARRANTED TO BE SUITABLE FOR USE IN LIFE-SUPPORT APPLICATIONS, DEVICES OR SYSTEMS OR OTHER CRITICAL APPLICATIONS.

Inclusion of TI products in such applications is understood to be fully at the risk of the customer. Use of TI products in such applications requires the written approval of an appropriate TI officer. Questions concerning potential risk applications should be directed to TI through a local SC sales office.

In order to minimize risks associated with the customer's applications, adequate design and operating safeguards should be provided by the customer to minimize inherent or procedural hazards.

TI assumes no liability for applications assistance, customer product design, software performance, or infringement of patents or services described herein. Nor does TI warrant or represent that any license, either express or implied, is granted under any patent right, copyright, mask work right, or other intellectual property right of TI covering or relating to any combination, machine, or process in which such semiconductor products or services might be or are used.