

DATA SHEET

PCE84C886

Microcontroller for monitor OSD
and auto-sync applications

Preliminary specification
File under Integrated Circuits, IC14

1996 Jan 08

Microcontroller for monitor OSD and auto-sync applications

PCE84C886

CONTENTS	12	OSD CONTROL REGISTERS
1 FEATURES	12.1	Derivative Register 22
1.1 General	12.2	Derivative Register 23
1.2 Special	12.3	Derivative Register 33
1.3 OSD	12.4	Derivative Register 34
2 GENERAL DESCRIPTION	12.5	Derivative Register 35
3 ORDERING INFORMATION	12.6	Derivative Register 36
4 BLOCK DIAGRAM	12.7	Derivative Register 37
5 PINNING INFORMATION	13	TO FORMAT THE OSD
5.1 Pinning	13.1	Number of characters per row
5.2 Pin description	13.2	Number of rows per frame
6 RESET	13.3	Character size selection for different display resolutions
6.1 Reset trip level	14	8-BIT COUNTER (T3)
6.2 Reset status	15	I²C-BUS INTERFACE
7 ANALOG (DC) CONTROL	16	OUTPUT PORTS
7.1 6 and 7-bit PWM outputs	16.1	Mask options
7.2 14-bit PWM output	17	DERIVATIVE REGISTERS
7.3 A typical PWM output application	18	LIMITING VALUES
8 ANALOG-TO-DIGITAL CONVERTER (ADC)	19	DC CHARACTERISTICS
8.1 Conversion algorithm	20	AC CHARACTERISTICS
9 ON SCREEN DISPLAY (OSD)	21	DEVELOPMENT SUPPORT
9.1 Horizontal starting position control	22	PACKAGE OUTLINE
9.2 Vertical starting position control	23	SOLDERING
9.3 On-chip clock generator	23.1	Introduction
10 DISPLAY RAM ORGANIZATION	23.2	Soldering by dipping or by wave
10.1 Description of display RAM codes	23.3	Repairing soldered joints
10.2 Default values of OSD after Power-on-reset	24	DEFINITIONS
10.3 Loading character data into display RAM	25	LIFE SUPPORT APPLICATIONS
10.4 Writing character data into display RAM	26	PURCHASE OF PHILIPS I²C COMPONENTS
11 CHARACTER ROM		
11.1 Character ROM address map		
11.2 Character ROM organization		
11.3 Combination of character font cells		

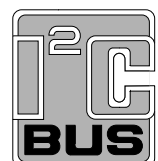

Microcontroller for monitor OSD and auto-sync applications

PCE84C886

1 FEATURES

1.1 General

- CMOS 8-bit CPU (enhanced 8048 CPU) with 8 kbytes system ROM and 192 bytes system RAM
- One 8-bit timer/event counter (T1) and one 8-bit counter triggered by external input (T3)
- Four single level vectored interrupt sources: external (INTN), counter/timer, I²C-bus and VSYNCN
- 2 directly testable inputs T0 and T1
- On-chip oscillator clock frequency: 1 to 10 MHz
- On-chip Power-on-reset with low power detector
- Twelve quasi-bidirectional I/O lines, configuration of each I/O line individually selected by mask option
- Idle and Stop modes for reduced power consumption
- Operating temperature: -25 to +85 °C
- Operating voltage: 4.5 to 5.5 V
- Package: SDIP42.

1.2 Special

- Master-slave I²C-bus interface
- Four 6-bit Pulse Width Modulated outputs (PWM4 to PWM7)
- Four 7-bit Pulse Width Modulated outputs (PWM0 to PWM3)
- One 14-bit Pulse Width Modulated output (PWM8)
- Three 4-bit ADC channels
- 16 derivative I/O ports.

1.3 OSD

- Maximum dot frequency (f_{OSD}): 14 MHz
- Display RAM: 64 × 10 bits
- Display character fonts: 62 + 2 special reserved codes
- Character matrix: 12 × 18 (no spacing between characters)
- 4 character sizes: 1H/1V, 1H/2V, 1H/3V and 1H/4V
- 64 Horizontal starting positions (4 dots for each step)
- 64 Vertical starting positions (4 scan lines for each step)

- Spacing between character rows: 0, 4, 8 and 12 scan lines
- Foreground colours: 8 on a character-by-character basis
- Background colours: 8 on a word-by-word basis
- Background/shadowing modes: 4 modes available, No background, North shadowing, Box shadowing and Frame shadowing (raster blanking) on a frame basis
- On-chip Phase-Locked Loop (PLL) oscillator (auto-sync with HSYNCN) with programmable oscillator for On Screen Display (OSD) function
- Character blinking frequency: programmable using f_{Vsync} divisors of 16, 32, 64 and 128; on a frame basis
- Character blinking ratios: 1 : 1, 1 : 3 and 3 : 1
- Programmable active level polarities of VSYNCN, HSYNCN, R, G, B and FB
- Flexible display format by using Carriage Return Code
- Auto display RAM address (DCRAR) incremented after write operation to the Character Data Register (DCRCR)
- VSYNCN generates an interrupt (enabled by software) when VIEN is active.

2 GENERAL DESCRIPTION

The PCE84C886 is a member of the 84CXXX CMOS microcontroller family. It is suitable for use in 14", 15" and 17" auto-sync monitors for OSD and auto-sync applications. The device uses the PCE84CXX processor core and has 8 kbytes of ROM and 192 bytes of RAM. I/O requirements are adequately catered for with 12 general purpose bidirectional I/O lines plus 16 function combined I/O lines. 9 PWM analog outputs are provided specifically for analog control purposes and also three 4-bit ADCs. The device has an 8-bit counter, suitable for use in pulse counting applications; an 8-bit timer/counter with programmable clock and an on-chip programmable PLL oscillator that generates the OSD clock. In addition to all these features a master-slave I²C-bus interface, 2 directly testable lines and an enhanced OSD facility for flexible screen format (64 character types) are also provided.

The block diagram of the PCE84C886 is shown in Fig.1.

3 ORDERING INFORMATION

TYPE NUMBER	PACKAGE		
	NAME	DESCRIPTION	VERSION
PCE84C886	SDIP42	plastic shrink dual in-line package; 42 leads (600 mil)	SOT270-1

Microcontroller for monitor OSD
and auto-sync applications

PCE84C886

4 BLOCK DIAGRAM

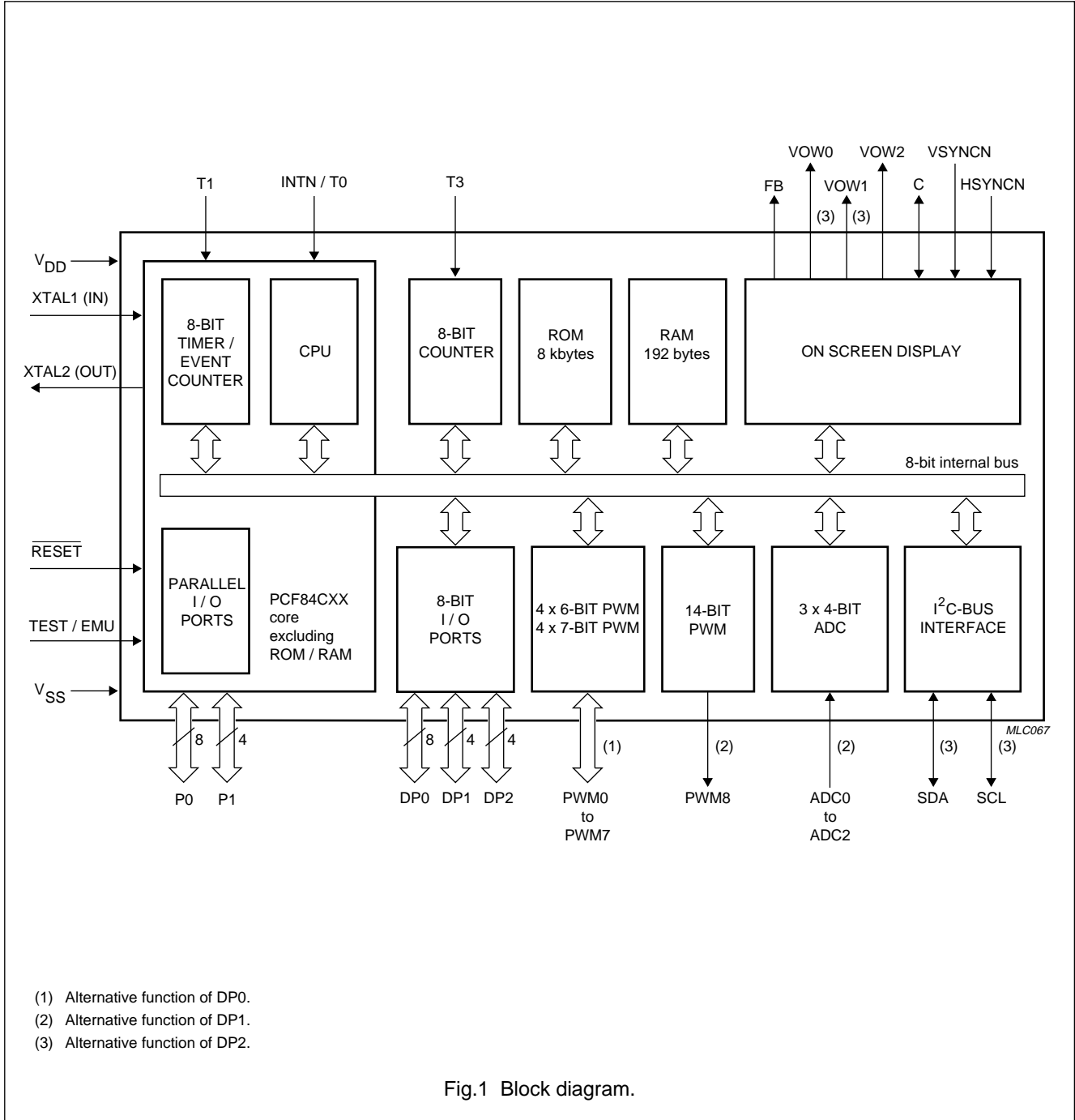

Microcontroller for monitor OSD
and auto-sync applications

PCE84C886

5 PINNING INFORMATION

5.1 Pinning

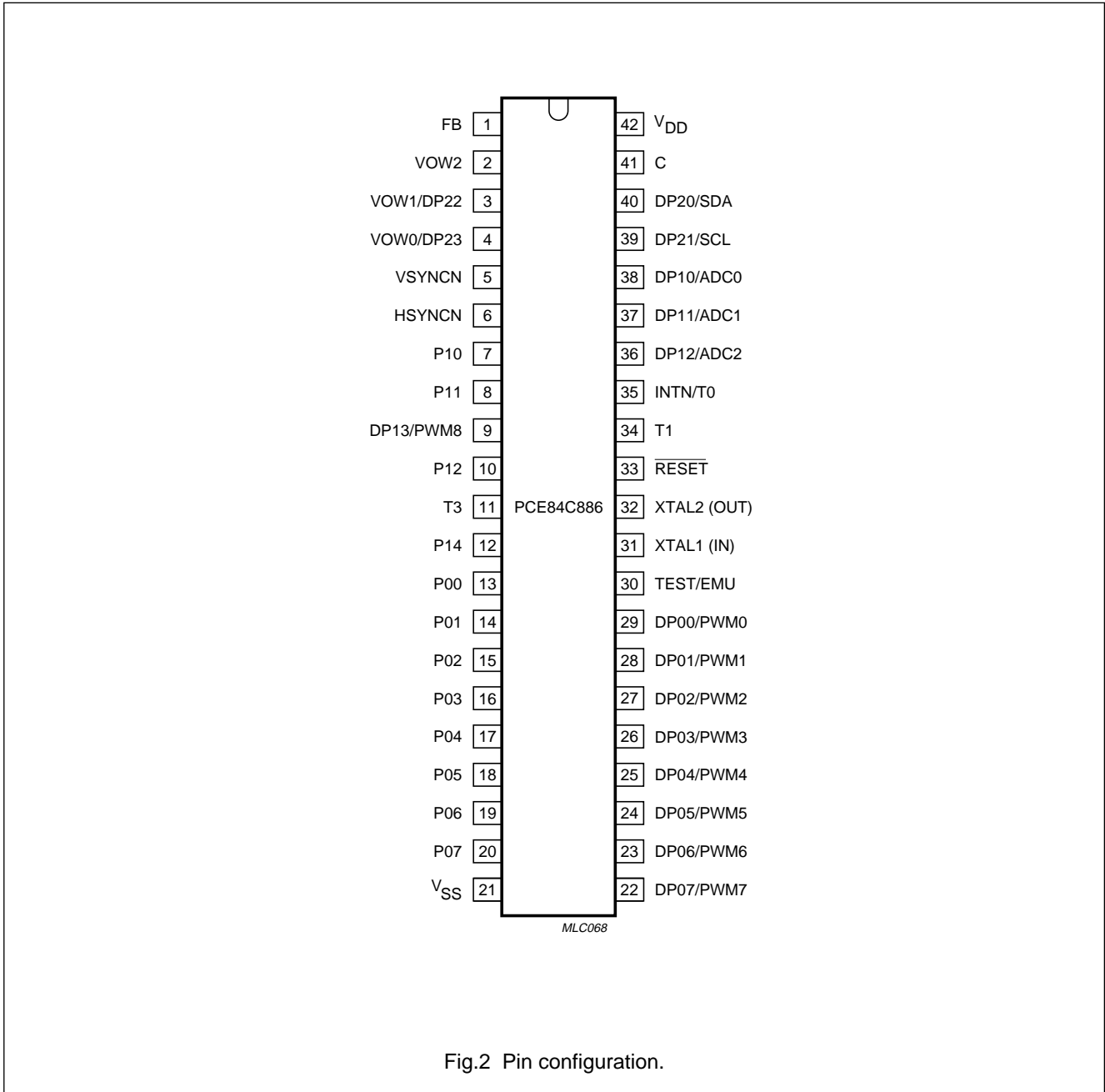

Fig.2 Pin configuration.

Microcontroller for monitor OSD and auto-sync applications

PCE84C886

5.2 Pin description

Table 1 SDIP42 package

SYMBOL	PIN	DESCRIPTION
FB	1	Video Fast Blanking output.
VOW2	2	Video character output VOW2.
VOW1/DP22	3	Video character output VOW1 or Derivative Port line DP22.
VOW0/DP23	4	Video character output VOW0 or Derivative Port line DP23.
VSYNCN	5	Vertical synchronization signal input.
HSYNCN	6	Horizontal synchronization signal input.
P10	7	Port line 10 or emulation input \overline{DXWR} .
P11	8	Port line 11 or emulation input \overline{DXRD} .
DP13/PWM8	9	Derivative I/O port or PWM8 output.
P12	10	Port line 12 or emulation input DXALE.
T3	11	Secondary 8-bit counter input (Schmitt trigger).
P14	12	Port line 14 or emulation output DXINT.
P00 to P07	13 to 20	General I/O port lines.
V _{SS}	21	Ground.
DP00/PWM0 to DP07/PWM7	29, 28, 27, 26 25, 24, 23, 22	Derivative I/O ports or PWM outputs.
TEST/EMU	30	Control input for testing and emulation mode, normally LOW.
XTAL1 (IN)	31	Oscillator input pin for system clock.
XTAL2 (OUT)	32	Oscillator output pin for system clock.
\overline{RESET}	33	Reset input; active LOW input initializes device.
T1	34	Direct testable pin or event counter input.
INTN/T0	35	External interrupt or direct testable pin.
DP10/ADC0	38	Derivative I/O port or ADC Channel 0 input.
DP11/ADC1	37	Derivative I/O port or ADC Channel 1 input.
DP12/ADC2	36	Derivative I/O port or ADC Channel 2 input.
DP21/SCL	39	Derivative port line or I ² C-bus clock input.
DP20/SDA	40	Derivative port line or I ² C-bus data input.
C	41	External capacitor input for on-chip oscillator.
V _{DD}	42	Power supply.

Microcontroller for monitor OSD and auto-sync applications

PCE84C886

6 RESET

The $\overline{\text{RESET}}$ pin may be used as an active LOW input to initialize the microcontroller to a defined state.

An active reset can be generated by driving the $\overline{\text{RESET}}$ pin from an external logic device. Such an active reset pulse should not fall off before V_{DD} has reached its f_{xtal} -dependent minimum operating voltage.

A Power-on-reset can be generated using an external RC circuit. To avoid overload of the internal diode, an external diode should be added in parallel if $C_{\text{RESET}} \geq 2.2 \mu\text{F}$. The RC circuit is shown in Fig.3.

6.1 Reset trip level

The RESET trip voltage level is masked to 1.3 V in the PCE84C886.

If any input (for example Hsync) goes HIGH before V_{DD} is applied, latch-up may occur and in this situation the PCE84C886 cannot be reset. The cause and effect of latch-up is shown in Fig.4.

6.2 Reset status

- Derivative Registers reset status; see Table 38 for details
- Program Counter 00H
- Memory Bank 0
- Register Bank 0
- Stack Pointer 00H
- All interrupts disabled
- Timer/event counter 1 stopped and cleared
- Timer pre-scaler modulo-32 ($\text{PS} = 0$)
- Timer flag cleared
- Serial I/O interface disabled ($\text{ESO} = 0$) and in slave receiver mode
- Idle and Stop mode cleared.

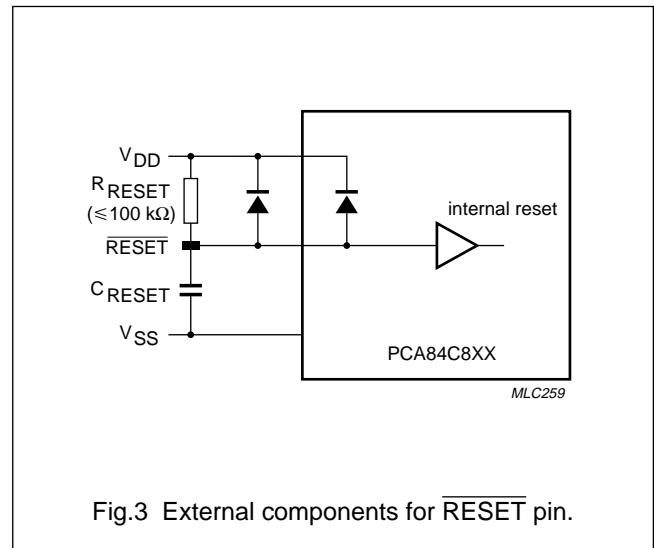

Fig.3 External components for $\overline{\text{RESET}}$ pin.

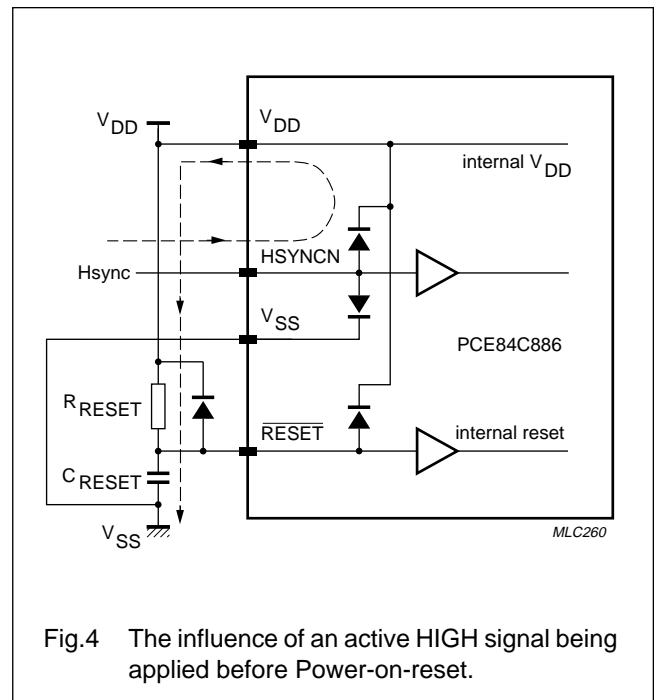

Fig.4 The influence of an active HIGH signal being applied before Power-on-reset.

Microcontroller for monitor OSD and auto-sync applications

PCE84C886

7 ANALOG (DC) CONTROL

The PCE84C886 has nine Pulse Width Modulated (PWM) outputs for analog control purposes e.g. brightness, contrast, H-shift, V-shift, H-width, V-size, E-W, R (or G or B) gain control etc. Each PWM output generates a pulse pattern with a programmable duty cycle.

The nine PWM outputs are specified below:

- 4 PWM outputs with 6-bit resolution (PWM4 to PWM7)
- 4 PWM outputs with 7-bit resolution (PWM0 to PWM3)
- 1 PWM output with 14-bit resolution (PWM8).

The 6 and 7-bit PWM outputs are described in Section 7.1; the 14-bit PWM output is described in Section 7.2 and a typical PWM output application is described in Section 7.3.

7.1 6 and 7-bit PWM outputs

PWM outputs PWM0 to PWM7 share the same pins as Derivative Port lines DP00 to DP07 respectively. Selection of the pin function as either a PWM output or a Derivative Port line is achieved using the appropriate PWMnE bit in Register 21 (see Table 38).

The polarity of the PWM outputs is programmable and is selected by the P7LVL and P6LVL bits in Register 23 (see Section 12.2).

The duty cycle of outputs PWM0 to PWM7 is dependent on the programmable contents of the data latches (Registers 10 to 17 respectively). As the clock frequency of each PWM circuit is $\frac{1}{3} \times f_{xtal}$, the pulse width of the pulse generated can be calculated as shown below.

$$\text{Pulse width} = \frac{3 \times (\text{PWMn})}{f_{xtal}}$$

Where (PWMn) is the decimal value held in the data latch.

The maximum repetition frequency (f_{PWM}) of the 6 and 7-bit PWM outputs is shown below.

$$\text{For the 6-bit PWM outputs: } f_{PWM} = \frac{f_{xtal}}{192}$$

$$\text{For the 7-bit PWM outputs: } f_{PWM} = \frac{f_{xtal}}{384}$$

The block diagram for the 6 and 7-bit PWM outputs is shown in Fig.5.

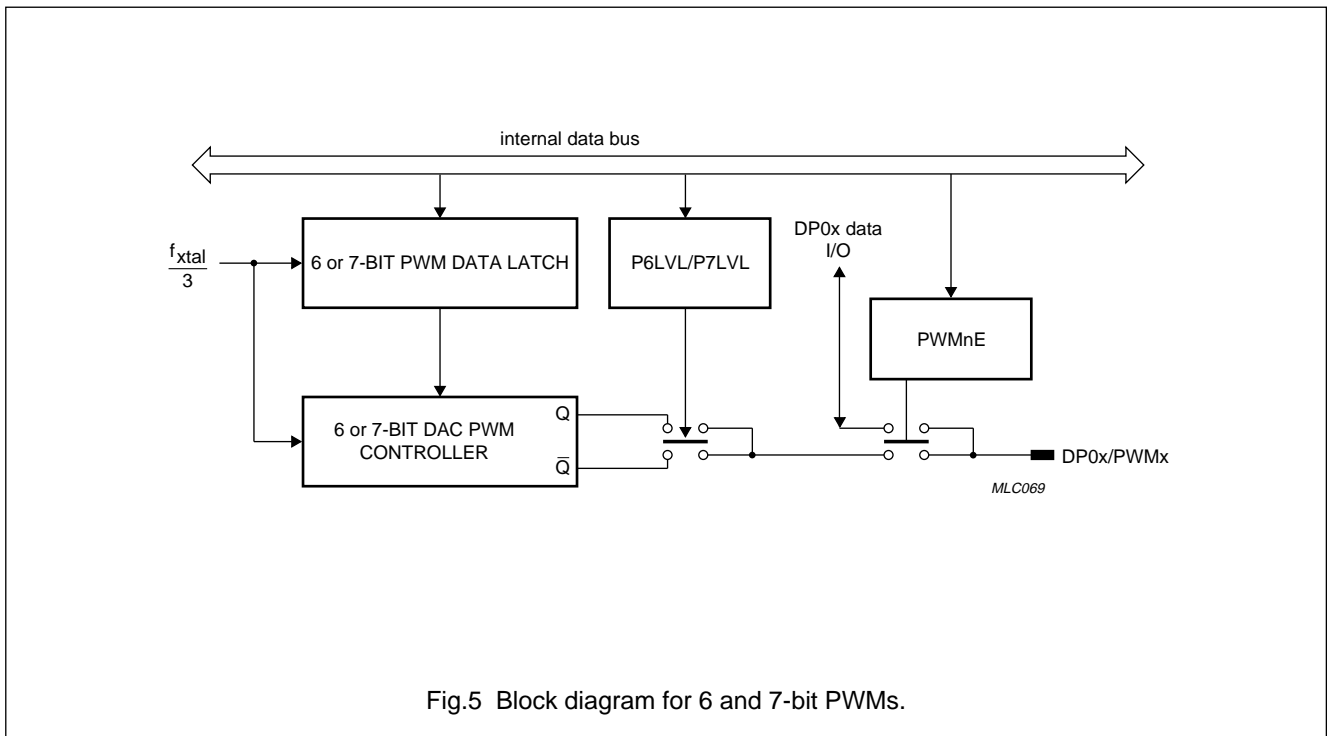

Fig.5 Block diagram for 6 and 7-bit PWMs.

Microcontroller for monitor OSD and auto-sync applications

PCE84C886

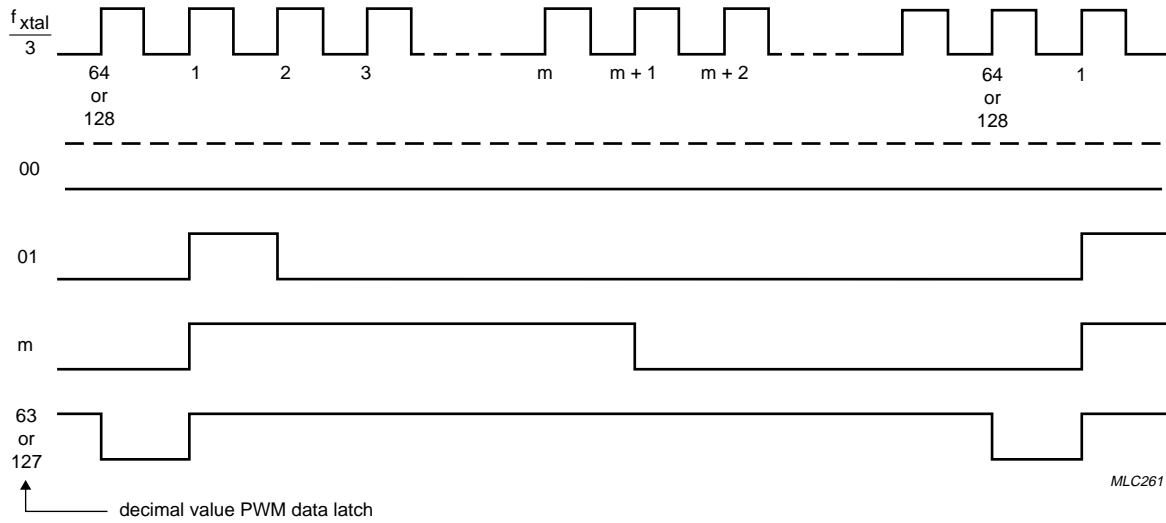

Fig.6 Typical non-inverted output pulse patterns for 6 or 7-bit PWM outputs.

Microcontroller for monitor OSD and auto-sync applications

PCE84C886

7.2 14-bit PWM output

PWM8 shares the same pin as Derivative Port line DP13. Selection of the pin function as either a PWM output or as a Derivative Port line is achieved using the PWM8E bit in Register 22 (see Section 12.1).

The Block diagram for the 14-bit PWM output is shown in Fig.7 and comprises:

- Two 7-bit latches: PWM8L (Register 18) and PWM8H (Register 19)
- 14-bit data latch (PWMREG)
- 14-bit counter
- Coarse pulse controller
- Fine pulse controller
- Mixer.

Data is loaded into the 14-bit data latch (PWMREG) from the two 7-bit data latches (PWM8H and PWM8L) when either of these data latches is written to. The upper seven bits of PWMREG are used by the coarse pulse controller and determine the coarse pulse width; the lower seven bits are used by the fine pulse controller and determine in which subperiods fine pulses will be added. The outputs OUT1 and OUT2 of the coarse and fine pulse controllers are 'ORED' in the mixer to give the PWM8 output. The polarity of the PWM8 output is programmable and is selected by the P8LVL bit in Register 23, this is described in Section 12.2.

As the 14-bit counter is clocked by $f_{xtal}/3$, the repetition times of the coarse and fine pulse controllers may be calculated as shown below.

$$\text{Coarse controller repetition time: } t_{sub} = \frac{384}{f_{xtal}}$$

$$\text{Fine controller repetition time: } t_r = \frac{49152}{f_{xtal}}$$

Figure 8 shows typical PWM8 outputs, with coarse adjustment only, for different values held in PWM8H. Figure 9 shows typical PWM8 outputs, with coarse and fine adjustment, after the coarse and fine pulse controller outputs have been 'ORED' by the mixer.

7.2.1 COARSE ADJUSTMENT

An active HIGH pulse is generated in every subperiod; the pulse width being determined by the contents of PWM8H. The coarse output (OUT1) is LOW at the start of each subperiod and will remain LOW until the time $[3/f_{xtal} \times (PWM8H + 1)]$ has elapsed. The output will then go HIGH and remain HIGH until the start of the next subperiod. The coarse pulse width may be calculated as shown below.

$$\text{Pulse duration} = (127 - PWM8H) \times \frac{3}{f_{xtal}}$$

7.2.2 FINE ADJUSTMENT

Fine adjustment is achieved by generating an additional pulse in specific subperiods. The pulse is added at the start of the selected subperiod and has a pulse width of $3/f_{xtal}$. The contents of PWM8L determine in which subperiods a fine pulse will be added. It is the logic 0 state of the value held in PWM8L that actually selects the subperiods. When more than one bit is a logic 0 then the subperiods selected will be a combination of those subperiods specified in Table 2. For example, if PWM8L = 111 1010 then this is a combination of:

- PWM8L = 111 1110: subperiod 64 and
- PWM8L = 111 1011: subperiods 16, 48, 80 and 112.

Pulses will be added in subperiods 16, 48, 64, 80 and 112. This example is illustrated in Fig.10.

When PWM8L holds 111 1111 fine adjustment is inhibited and the PWM8 output is determined only by the contents of PWM8H.

Table 2 Additional pulse distribution

PWM8L	ADDITIONAL PULSE IN SUBPERIOD
111 1110	64
111 1101	32 and 96
111 1011	16, 48, 80 and 112
111 0111	8, 24, 40, 56, 72, 88, 104 and 120
110 1111	4, 12, 20, 28, 36, 44, 52...116 and 124
101 1111	2, 6, 10, 14, 18, 22, 26, 30...122 and 126
011 1111	1, 3, 5, 7, 9, 11, 13, 15, 17...125 and 127

Microcontroller for monitor OSD
and auto-sync applications

PCE84C886

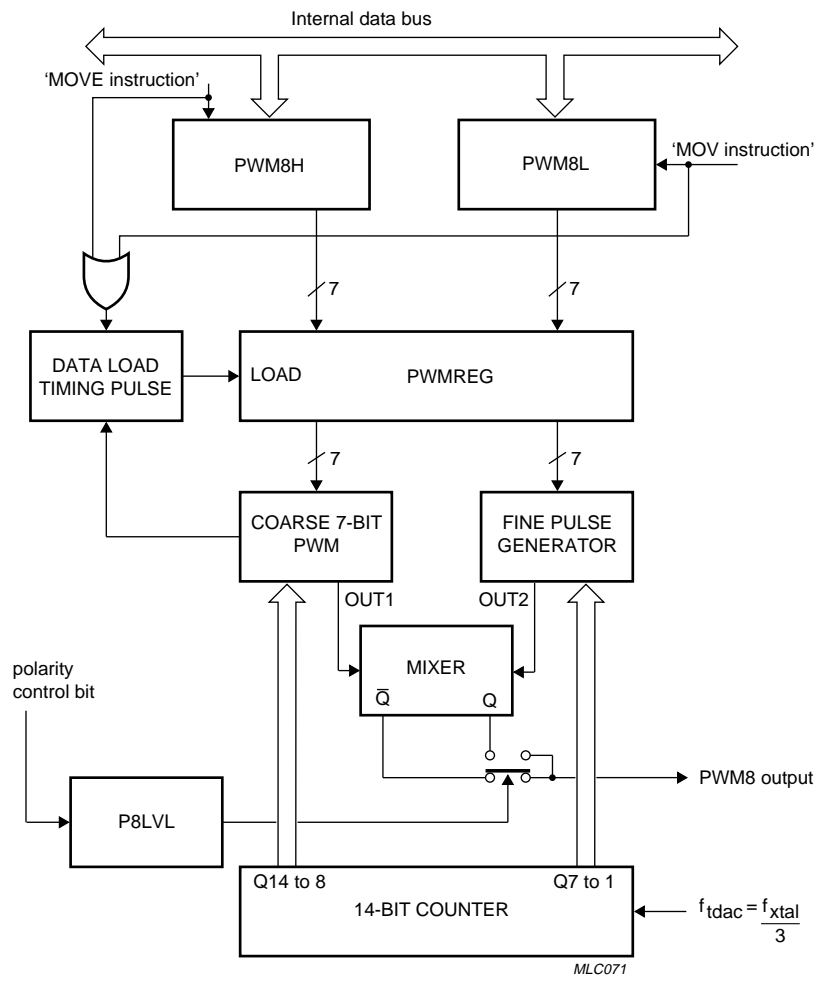

Fig.7 14-bit PWM Block diagram.

Microcontroller for monitor OSD
and auto-sync applications

PCE84C886

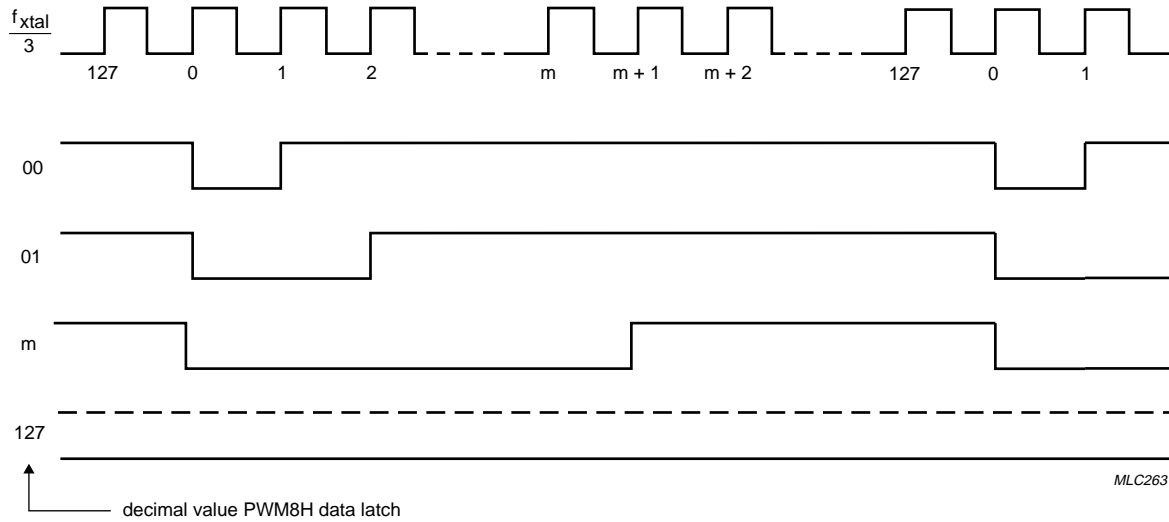

Fig.8 Non-inverted PWM8 output patterns - Coarse adjustment only.

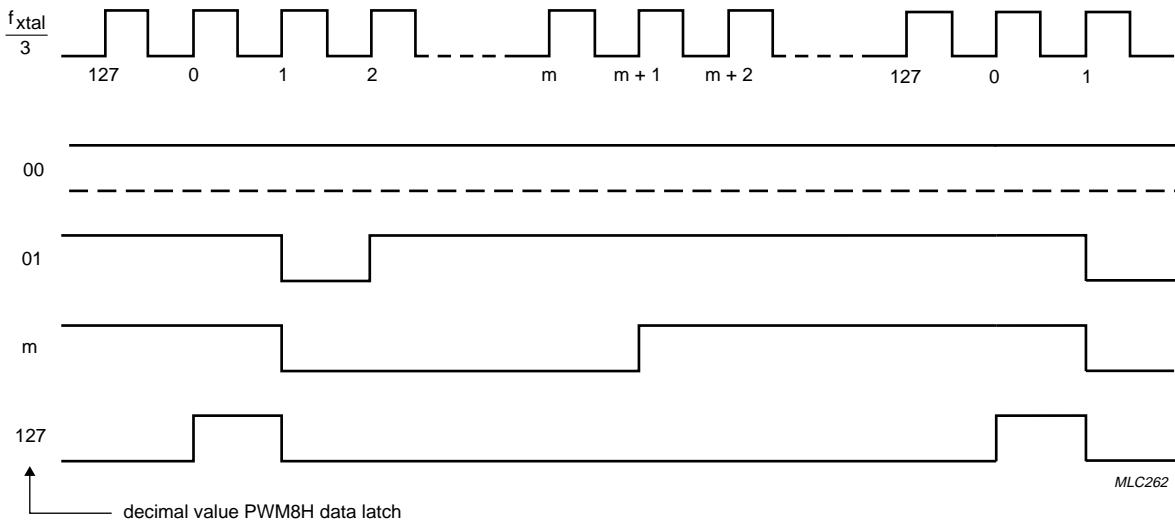

Fig.9 Non-inverted PWM8 output patterns - Coarse and Fine adjustment.

Microcontroller for monitor OSD
and auto-sync applications

PCE84C886

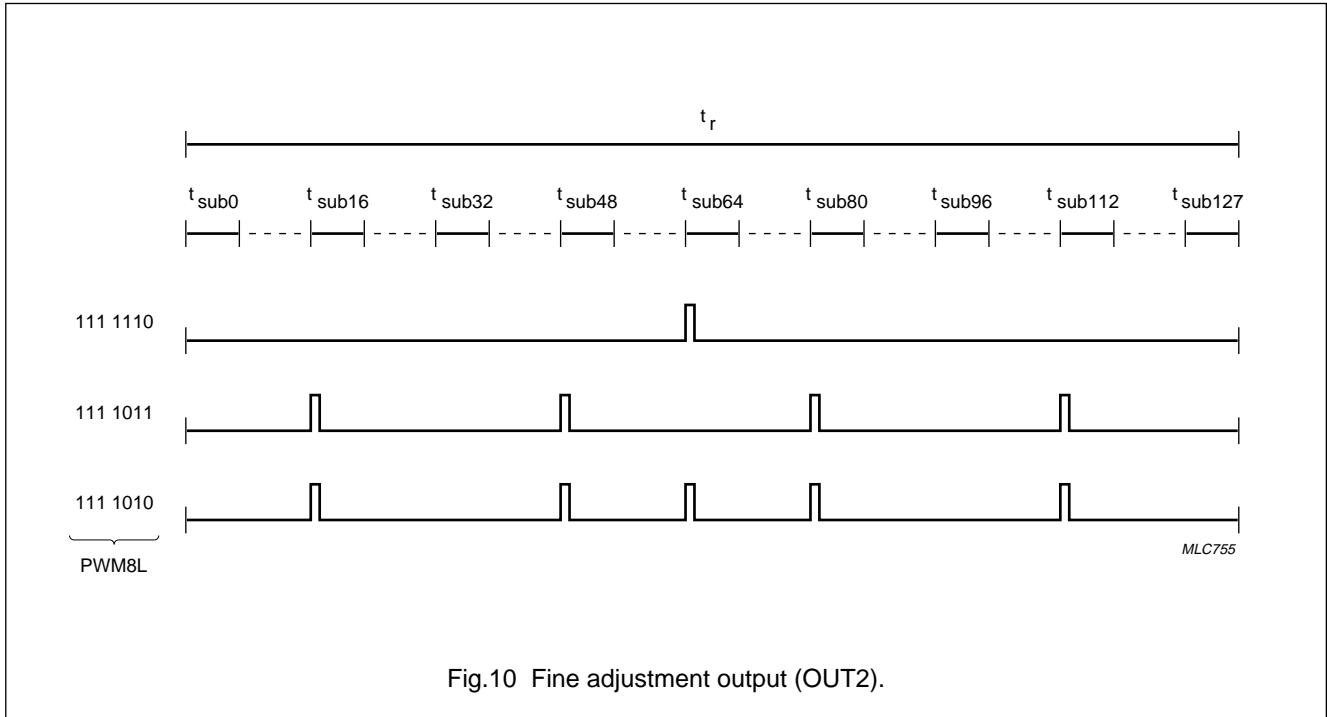

Fig.10 Fine adjustment output (OUT2).

7.3 A typical PWM output application

A typical PWM application is shown in Fig.11. The buffer is used to reduce jitter on the OSD. R1 and C1 form the integration network the time constant of which should be equal to or greater than 5 times the repetition period of the PWM output pattern. In order to smooth a changing PWM output a high value of C1 should be chosen. The value of C1 will normally be in the range 1 to 10 μF. The potential divider chain formed by R2 and R3 is used only when the output voltage is to be offset. The output voltages for this application are calculated using Equations (1) and (2).

$$V_{max} = \frac{R3 \times \text{supply voltage}}{R3 + \frac{R1 \times R2}{R1 + R2}} \quad (1)$$

$$V_{min} = \frac{\frac{R1 \times R3}{R1 + R3} \times \text{supply voltage}}{R2 + \frac{R1 \times R3}{R1 + R3}} \quad (2)$$

The loop from the PWM pin through R1 and C1 to V_{SS} will radiate high frequency energy pulses. In order to limit the effect of this unwanted radiation source, the loop should be kept short and a high value of R1 selected. The value of R1 will normally be in the range 3.3 to 100 kΩ. It is good practice to avoid sharing V_{SS} (pin 21) with the return leads of other sensitive signals.

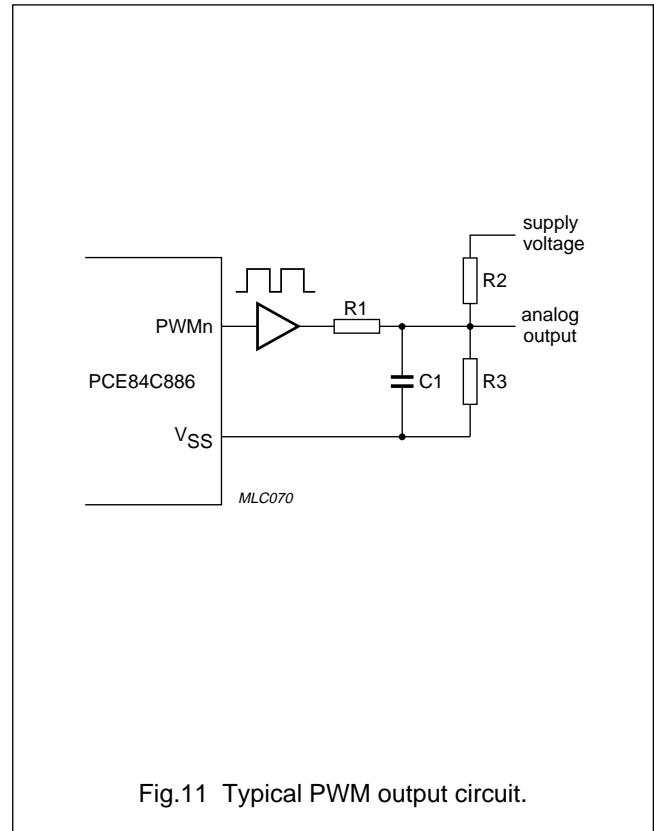

Fig.11 Typical PWM output circuit.

Microcontroller for monitor OSD
and auto-sync applications

PCE84C886

8 ANALOG-TO-DIGITAL CONVERTER (ADC)

The 3 channel ADC comprises a 4-bit Digital-to-Analog Converter (DAC); a comparator; an analog channel selector and control circuitry. As the digital input to the 4-bit DAC is loaded by software (a subroutine in the program), it is known as a software ADC. The block diagram is shown in Fig.12.

The ADC inputs ADC0 to ADC2 share the same pins as Derivative Port lines DP10 to DP12 respectively. Selection of the pin function as either an ADC input or as a Derivative Port line is achieved using bits ADCE0 to ADCE2 in Register 22. When ADCE_n = 1, the ADC function is enabled (see Section 12.1).

The 4-bit DAC analog output voltage (V_{ref}) is determined by the decimal value of the data held in bits DAC0 to DAC3 of Register 20. V_{ref} is calculated as shown in Equation (3) and Table 3 lists the V_{ref} values assuming V_{DD} = 5 V.

$$V_{ref} = \frac{V_{DD}}{16} \times (\text{DAC value} + 1) \tag{3}$$

When the analog input voltage is higher than V_{ref}, the COMP bit in Register 20 will be HIGH.

Table 3 Selection of V_{ref}

DAC3	DAC2	DAC1	DAC0	V _{ref} (V)
0	0	0	0	0.3125
0	0	0	1	0.6250
0	0	1	0	0.9375
0	0	1	1	1.2500
0	1	0	0	1.5625
0	1	0	1	1.8750
0	1	1	0	2.1875
0	1	1	1	2.5000
1	0	0	0	2.8125
1	0	0	1	3.1250
1	0	1	0	3.4375
1	0	1	1	3.7500
1	1	0	0	4.0625
1	1	0	1	4.3750
1	1	1	0	4.6875
1	1	1	1	5.0000

The channel selector, consisting of three analog switches, is controlled by bits ADCS1 and ADCS0 in Register 20 as highlighted in Table 4.

Table 4 Selection of ADC channel

ADCS1	ADCS0	CHANNEL SELECTED
0	0	ADC0
0	1	ADC1
1	0	ADC2
1	1	reserved

8.1 Conversion algorithm

There are many algorithms available to achieve the ADC conversion. The algorithm described below and shown in Fig.13 uses an iteration process.

1. Select ADC_n channel for conversion. Channel selection is achieved using bits ADCS1 and ADCS0 in Register 20.
2. Set the digital input to the DAC to 1000. The digital input to the DAC is selected using bits DAC3 to DAC0 in Register 20.
3. Determine the result of the compare operation. This is achieved by reading the COMP bit in Register 20 using the instruction MOV A, D20. If COMP = 1; the analog input voltage is higher than the reference voltage (V_{ref}). If COMP = 0; the analog input voltage is lower than the reference voltage (V_{ref}).
4. If COMP = 1; then the analog input voltage is higher than the reference voltage (V_{ref}) and therefore the digital input to the DAC needs to be increased. Set the input to the DAC to 1100.
5. If COMP = 0; then the analog input voltage is lower than the reference voltage (V_{ref}) and therefore the digital input to the DAC needs to be decreased. Set the input to the DAC to 0100.
6. Determine the result of the compare operation by reading the COMP bit in Register 20.

Microcontroller for monitor OSD
and auto-sync applications

PCE84C886

- 7. For the DAC = 1100 case
If COMP = 1; then the analog input voltage is still greater than V_{ref} and therefore the digital input to the DAC needs to be increased again. Set the input to the DAC to 1110.
If COMP = 0; then the analog input voltage is now less than V_{ref} and therefore the digital input to the DAC needs to be decreased. Set the input to the DAC to 1010.
- 8. For the DAC = 0100 case
If COMP = 1; then the analog input voltage is now greater than V_{ref} and therefore the digital input to the DAC needs to be increased. Set the input to the DAC to 0110.
If COMP = 0; then the analog input voltage is still lower than V_{ref} and therefore the digital input to the DAC needs to be decreased again. Set the input to the DAC to 0010.

- 9. The operations detailed in 6, 7 and 8 above are repeated and each time the digital input to the DAC is changed accordingly; as dictated by the state of the COMP bit. The complete process is shown in Fig.13. Each time the DAC input is changed the number of values which the analog input can take is reduced by half. In this manner the actual analog value is honed into. The value of the analog input (V_A) is determined using Equation (4):

$$V_A = \frac{V_{DD}}{16} \times (\text{DAC value} + 1) \tag{4}$$

As the conversion time of each compare operation is greater than 6 μ s but less than 9 μ s; a NOP instruction is recommended to be used in between the instructions that change the value of V_{ref} ; select the ADC channel and read the COMP bit.

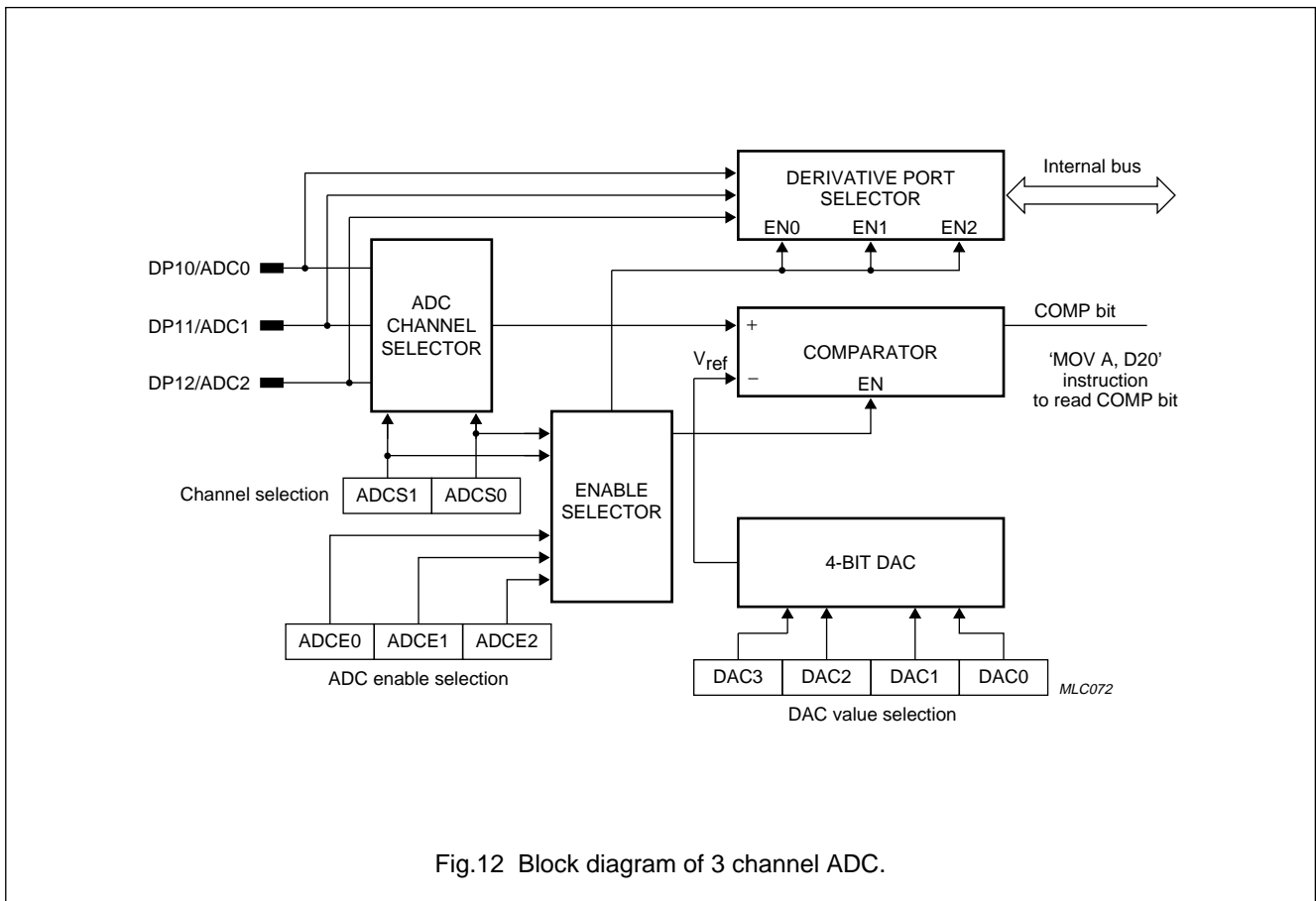

Fig.12 Block diagram of 3 channel ADC.

Microcontroller for monitor OSD
and auto-sync applications

PCE84C886

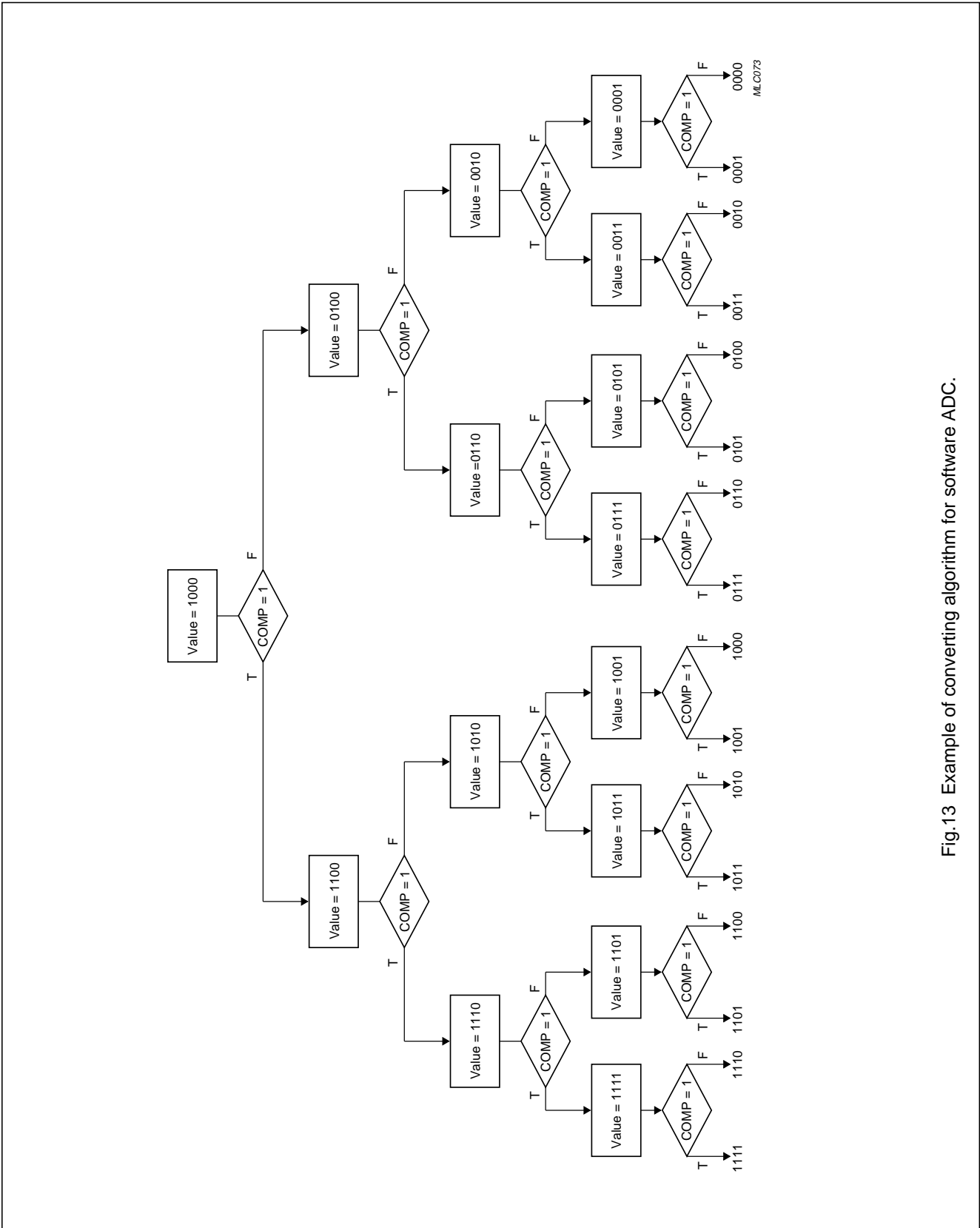

Fig.13 Example of converting algorithm for software ADC.

Microcontroller for monitor OSD and auto-sync applications

PCE84C886

9 ON SCREEN DISPLAY (OSD)

The OSD feature of the PCE84C886 enables the user to display information on the monitor screen. Display information can be created using 62 customer designed characters, a space character and a carriage return code. The OSD block diagram is shown in Fig.14.

9.1 Horizontal starting position control

The horizontal starting position counter is incremented every OSD clock after Hsync becomes inactive and is reset when Hsync becomes active. The horizontal starting position of the display row is determined by the contents of Register 36; 1 of 64 positions may be selected as explained in Section 12.6.

The polarity of the active state of the HSYNCN input is programmable and is determined by the Hp bit in Register 34; see Section 12.4. The active HIGH and active LOW states as selected by the Hp bit are shown in Fig.15.

9.2 Vertical starting position control

The vertical starting position counter is incremented every Hsync cycle and is reset when Vsync becomes active. The vertical starting position of the display row is determined by the contents of Register 35; 1 of 64 positions may be selected as explained in Section 12.5.

The vertical starting position of the display is dependent upon the number of scan lines per frame. To achieve the same starting position with different display resolutions, only the contents of Register 35 need to be changed, the contents of Register 36 remain the same. The lowest vertical starting position that can be selected, is located on the 256th scan-line. However, lower positions may be achieved using the Carriage Return Code.

When the selected horizontal and vertical starting positions are reached on screen; the OSD is enabled. The character selected in display RAM is then displayed.

The polarity of the active state of the VSYNCN input is programmable and is determined by the Vp bit in Register 34; see Section 12.4. The active HIGH and active LOW states as selected by the Vp bit are shown in Fig.15.

9.3 On-chip clock generator

The on-chip oscillator generates an OSD clock that is auto-sync with Hsync. The frequency of the OSD clock is programmable and is determined by the contents of Register 25 which forms the 7-bit counter.

The OSD clock frequency is calculated as follows:

$$f_{\text{OSD}} = f_{\text{Hsync}} \times 2 \times (\text{Register 25})$$

Where (Register 25) denotes the decimal value held in Register 25.

The block diagram of the OSD clock is shown in Fig.16. The internal reference frequency is connected to Hsync, and if the frequency of Hsync changes, the output frequency (f_{OSD}) will be changed linearly. Therefore, the character width is not effected by changes in the frequency of Hsync. The internal Hsync signal is designed active HIGH, consequently f_{PLL} is synchronized with the falling edge of this signal.

The OSD clock is enabled/disabled by the state of the EN bit in Register 34; see Section 12.4. When the OSD clock is disabled the oscillator remains active, therefore the transient time from the OSD clock start-up to locking into the external Hsync signal is reduced. As the on-chip oscillator is always active after power-on, when the OSD clock is enabled no large currents flow (as in the case of RC or LC oscillators) and therefore radiated noise is dramatically reduced.

Microcontroller for monitor OSD and auto-sync applications

PCE84C886

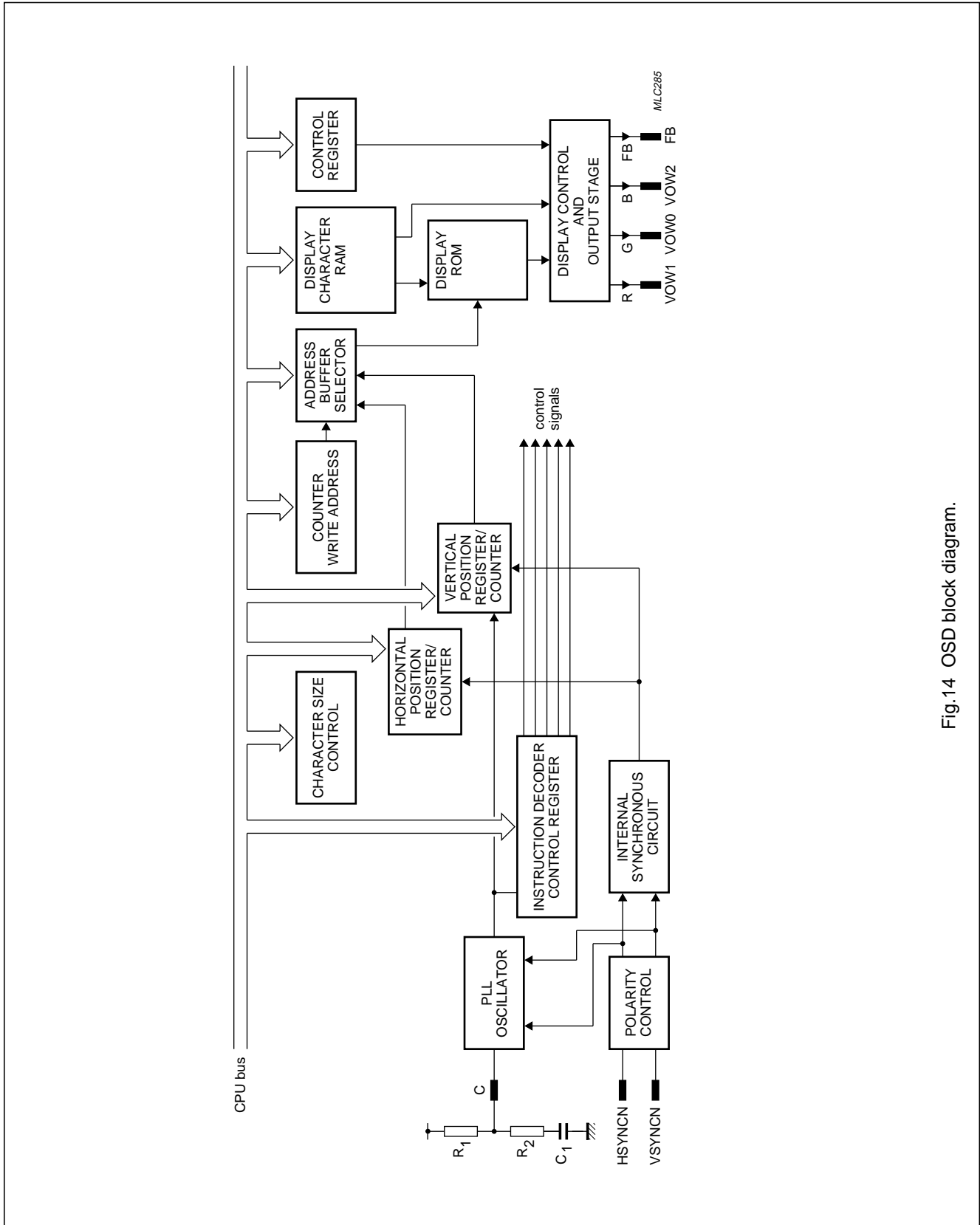

Fig.14 OSD block diagram.

Microcontroller for monitor OSD
and auto-sync applications

PCE84C886

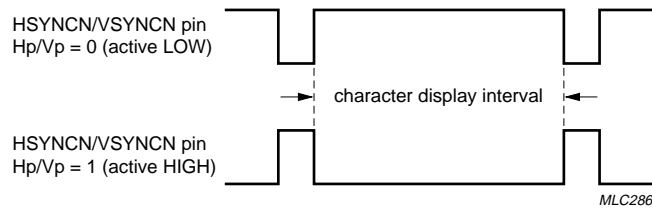

Fig.15 HSYNCN and VSNCN active level selection.

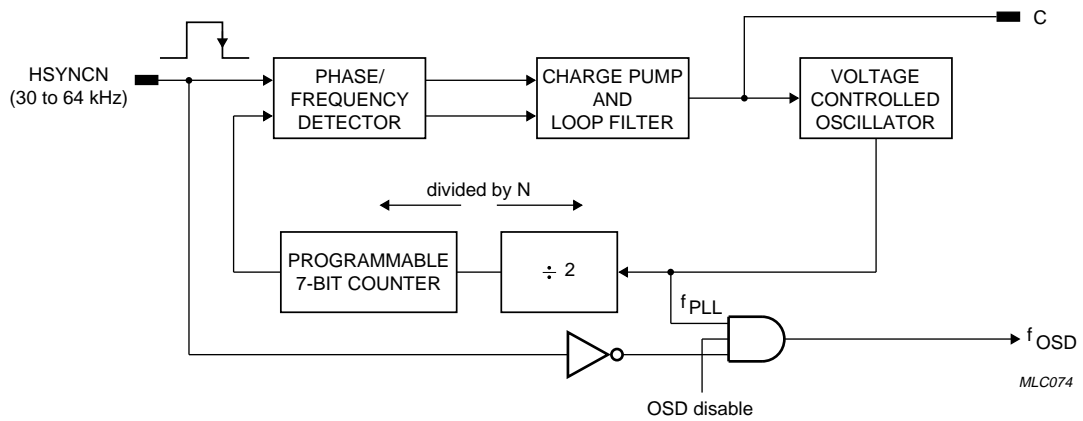

Fig.16 Block diagram for OSD oscillator.

Microcontroller for monitor OSD and auto-sync applications

PCE84C886

10 DISPLAY RAM ORGANIZATION

The display RAM is organized as 64 × 10 bits. The general format of each RAM location is as follows. Bits <9-4> hold character data (62 customer designed character fonts plus two reserved codes). Bits <3-0> contain the attributes of the character font, for example colour, character size, blinking etc.

10.1 Description of display RAM codes

There are three data formats for display RAM code:

1. Character Font Code
2. Carriage Return Code
3. Space Code.

The three data formats are shown in Tables 5, 6 and 7.

Table 5 Format of Character Font Code

9	8	7	6	5	4	3	2	1	0
C5	C4	C3	C2	C1	C0	T3	T2	T1	T0
Character Font Code (00H - 3DH)						Foreground colour		Blink	

Table 6 Format of Carriage Return Code

9	8	7	6	5	4	3	2	1	0
C5	C4	C3	C2	C1	C0	T3	T2	T1	T0
Carriage Return Code (3EH)						Character size		Line Spacing	

Table 7 Format of Space Code

9	8	7	6	5	4	3	2	1	0
C5	C4	C3	C2	C1	C0	T3	T2	T1	T0
Space Code (3FH)						Background colour		End	

Microcontroller for monitor OSD and auto-sync applications

PCE84C886

10.1.1 CHARACTER FONT CODE

If bits <9-4> are in the range (00H to 3DH), then this is a Character Font Code and 1 from 62 customer designed character fonts can be selected. Bits <3-1> determine the colour of the character, a choice of 8 colours being available. Bit <0> determines whether the character blinks or not. The format of the Character Font Code is shown in Table 5.

Table 8 Selection of Foreground colour

T3 (RED)	T2 (GREEN)	T1 (BLUE)	COLOUR
0	0	0	black
0	0	1	blue
0	1	0	green
0	1	1	cyan
1	0	0	red
1	0	1	magenta
1	1	0	yellow
1	1	1	white

Table 9 Selection of Blinking function

T0	BLINKING
0	OFF
1	ON

10.1.2 CARRIAGE RETURN CODE

If bits <9-4> hold 3EH, then this is the Carriage Return Code. The current display line is terminated (a transparent pattern appears on the screen) and the next character will be displayed at the beginning of the next line. Bits <3-2> select the size of the character to be displayed on the next line. Bits <1-0> determine the spacing between lines of displayed characters. Spacing is a multiple of the number of horizontal scan lines. In order to prevent vertical jumping of the display, the first line should be a non-displayed line i.e. the Carriage Return Code. The line spacing for this code must not be zero (see Table 11). The format of the Carriage Return Code is shown in Table 6.

Table 10 Selection of character size

T3	T2	CHARACTER DOT SIZE ⁽¹⁾
0	0	1H/1V
0	1	1H/2V
1	0	1H/3V
1	1	1H/4V

Note

1. H is the OSD clock period; V is the number of horizontal scan lines per dot.

Table 11 Selection of line spacing

T1	T0	LINE SPACING
0	0	0H line
0	1	4H line
1	0	8H line
1	1	12H line

10.1.3 SPACE CODE

If bits <9-4> hold 3FH, then this is the Space Code. A transparent pattern, equal to one character width, will be displayed on the screen. Bits <3-1> determine the background colour of the characters including the Space Code in Box shadowing mode but following the Space Code in North shadowing mode. See Sections 12.4 and 12.3.1 for more details. Background colour selection is the same as foreground colour selection. Bit <0> is the End-of-Display bit and indicates the end of display of the current screen before exhaustion of display RAM (i.e. before the 64th RAM location). The format of the Space Code is shown in Table 7.

Table 12 End of display control

T0	DISPLAY CONTROL
0	continue display of next character; this is also the default setting
1	end of display

Microcontroller for monitor OSD and auto-sync applications

PCE84C886

10.2 Default values of OSD after Power-on-reset

- Frequency of OSD clock: undefined, must be programmed
- Background/Shadowing mode: No background mode
- Background/Shadowing colour: blue
- Character size: 1H/1V
- OSD disabled
- Full 64 display RAM displayed (End-of-Display bit = 0)
- VOW1E and VOW0E disabled
- Horizontal starting position: 5th dot
- Vertical starting position: 256th scan-line
- Polarity of HSYNCR: active LOW
- Polarity of VSYNCR: active LOW
- Output polarities of FB, VOW0 to VOW2: active HIGH
- Blinking ratio: 3 : 1
- Blinking frequency: $\frac{1}{128} \times f_{Vsync}$
- Frame background colour: blue.

After a Power-on-reset, the OSD can be set-up as required by selecting the Space Code as the first character (address 0) and the Carriage Return Code as the next character (address 1). This procedure allows the user to select the initial background colour; character size and inter-line spacing.

10.3 Loading character data into display RAM

Three Derivative Registers are used to address and load data into the display RAM. These registers are described below.

10.3.1 DCR ADDRESS REGISTER (DCRAR)

This is Derivative Register 30 and holds the address of the location in display RAM to which the data held in registers DCRTR and DCRCR will be written to. 1 of 64 locations can be addressed. Bits 7 and 6 are reserved. The contents of this register are automatically incremented after each write operation to a RAM address, and become zero on overflow.

Table 13 DCR Address Register (DCRAR)

7	6	5	4	3	2	1	0
–	–	A5	A4	A3	A2	A1	A0

10.3.2 DCR ATTRIBUTE REGISTER (DCRTR)

This is Derivative Register 31 and holds the character font attribute data. The data will be loaded into bits <3-0> of the location in RAM pointed to by the contents of DCRAR. Bits 7 to 4 are reserved.

Table 14 DCR Attribute Register (DCRTR)

7	6	5	4	3	2	1	0
–	–	–	–	T3	T2	T1	T0

10.3.3 DCR CHARACTER REGISTER (DCRCR)

This is Derivative Register 32 and holds the character data that will be loaded into bits <9-4> of the location in RAM addressed by the contents of DCRAR. Bits 7 and 6 are reserved.

Table 15 DCR Character Register (DCRCR)

7	6	5	4	3	2	1	0
–	–	C5	C4	C3	C2	C1	C0

10.4 Writing character data into display RAM

The procedure for writing character data into the display RAM is as follows:

1. Select the start address in display RAM. The start address is stored in DCRAR and can take any value between 0 and 63.
2. Load the character attributes into DCRTR. If the attributes of a series of displayed characters are the same, only DCRCR needs to be updated.
3. Load the character data into DCRCR. The character data will specify either a Character Font Code, the Carriage Return Code or the Space Code. This operation loads the selected RAM location with the data held in registers DCRTR and DCRCR. The address held in DCRAR is then incremented by '1' pointing to the next RAM location in anticipation of the next operation.

After a master reset the contents of DCRAR, DCRTR and DCRCR are zero.

Microcontroller for monitor OSD and auto-sync applications

PCE84C886

11 CHARACTER ROM

64 character fonts may be held in ROM; 62 customer selected character fonts plus the Carriage Return Code and the Space Code. Customer selected fonts are mask programmable. Each character font is stored in a 12 × 19 dot matrix. However, only elements in Rows 1 to 18 can be selected as visible dots on the screen. Row 0 is only used for the combination of two characters in a vertical direction when North shadowing mode is selected.

11.1 Character ROM address map

Figure 17 shows the ROM address map. Addresses 3EH and 3FH hold the reserved codes for carriage return and space functions, respectively. Addresses (00H to 3DH) hold the customer selected character font codes.

11.2 Character ROM organization

ROM is divided into two parts: ROM1 and ROM2. The organization of the bit patterns stored in ROM 1 and ROM 2 and the file format to submit to Philips for customized character sets is shown in Fig.18. Regarding Fig.18 the following points should be noted.

1. Row 0 of each font is reserved for vertical combination of two fonts.
2. Binary 1 denotes visual dots.
3. ROM1 and ROM2 data files are in INTEL hex format on a byte basis. Each byte is structured high nibble followed by low nibble.
4. The unused last byte of each font in ROM1 must be filled with FFH.
5. The unused last 2½ bytes in ROM2 must be filled with the same data as held in the corresponding address in ROM1.
6. The data bytes of the last 2 reserved fonts (Carriage Return and Space Codes) should be filled with 00H.
7. CS denotes Checksum.

A software package (OSDGEM) that assists in the design of character fonts on-screen and that also automatically generates the bit pattern HEX files is available on request. The package is run under the MS-DOS environment for IBM compatible PCs.

11.3 Combination of character font cells

Two (or more) character font cells may be combined in a horizontal or vertical direction to create a new higher resolution pattern.

The combination of two cells in a horizontal direction is straight forward and requires no special precautions to be taken. When combining character cells in this manner all 4 Background/Shadowing modes are available. An example of combining two character font cells in a horizontal direction is shown in Fig.19.

However, the combination of two character font cells in a vertical direction is more difficult and care must be taken; otherwise, the new pattern may be created with gaps in its shadowing. An example of a character pattern with gaps is shown in Fig.20. Providing the steps listed below are followed no problems with shadowing will occur.

- The line spacing between two rows of characters must be programmed to 0H. This procedure is explained in Section 10.1.2.
- If the North shadowing mode is selected then when combining two character cells in a vertical direction Row 0 must contain the same bit pattern as held in Row 18 of the character directly above it. This is shown in Fig.21.
- If North shadowing is not required then Row 0 should contain all zeros.

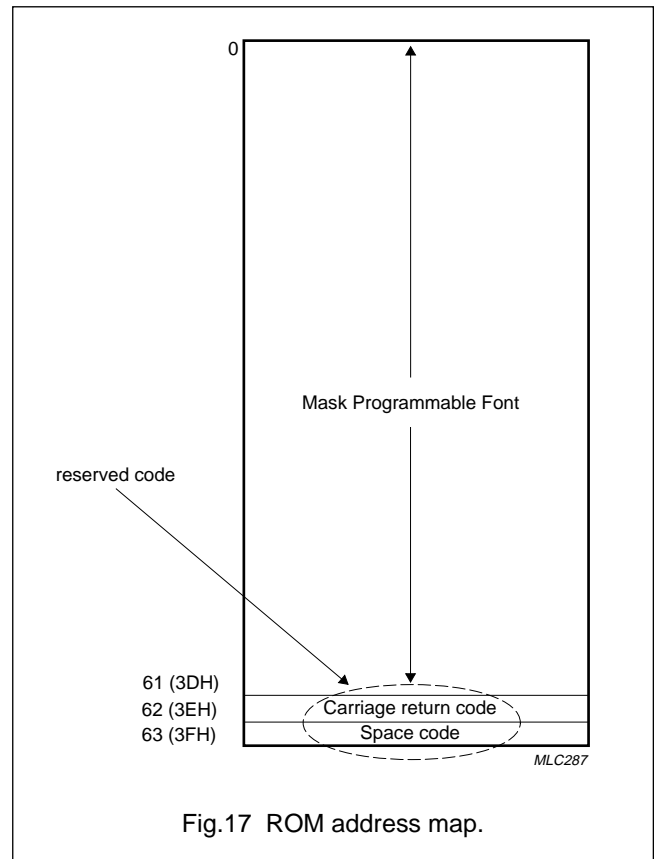

Fig.17 ROM address map.

Microcontroller for monitor OSD
and auto-sync applications

PCE84C886

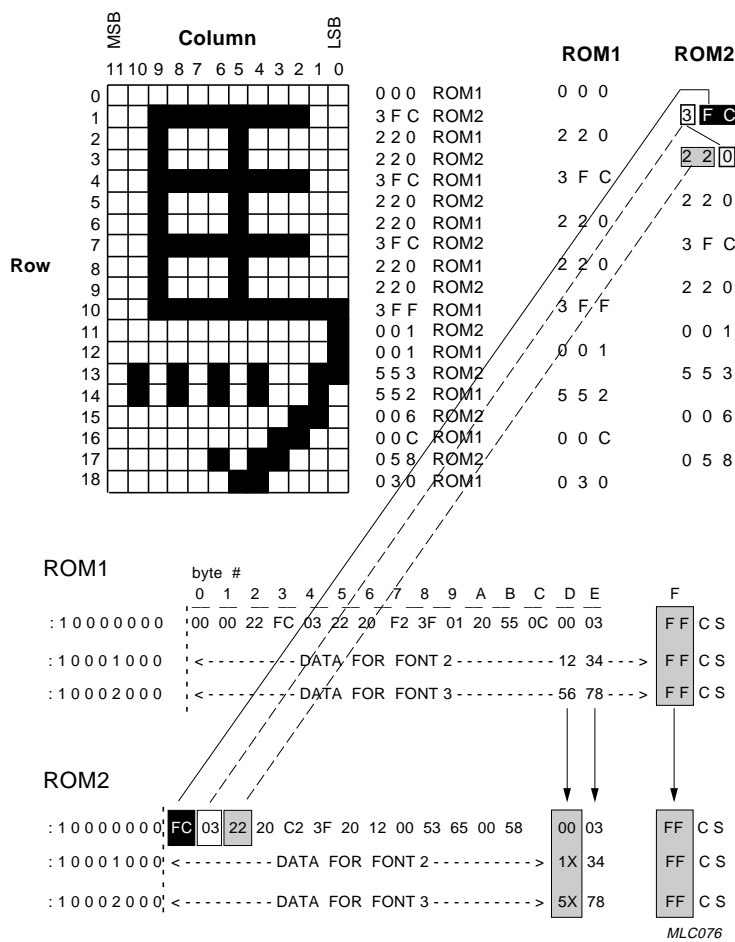
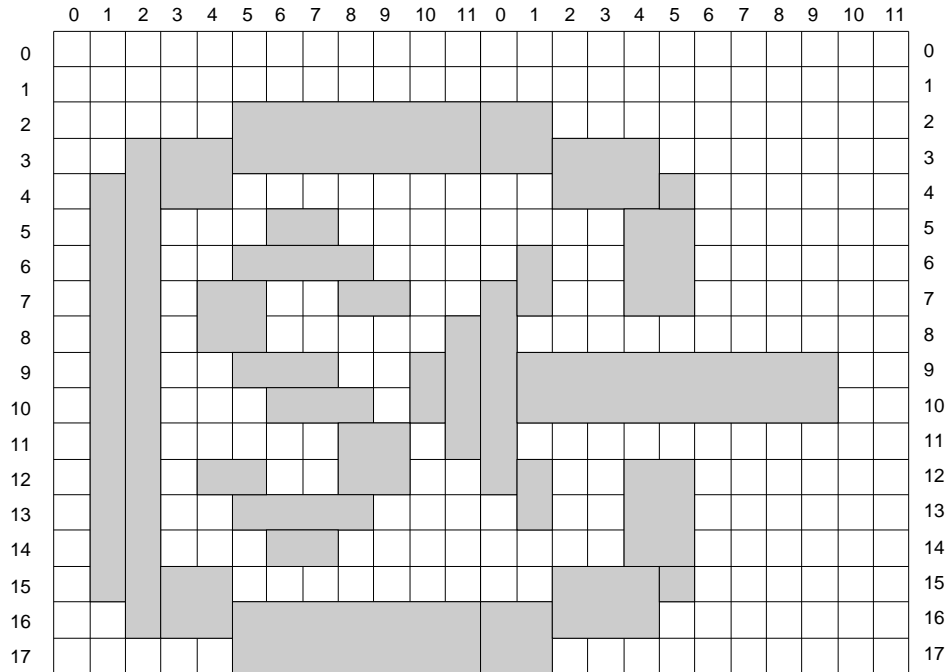

Fig.18 Character font pattern stored in ROM1 and ROM2.

Microcontroller for monitor OSD
and auto-sync applications

PCE84C886



(a) Character designed in character ROM

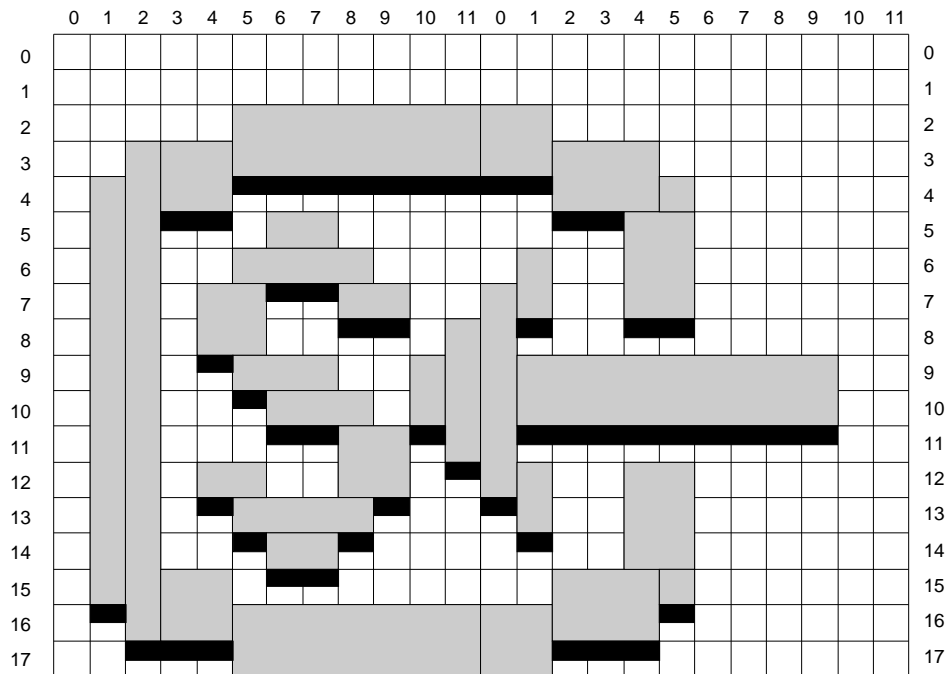

(b) North shadowing background mode display on screen

MLB402

Fig.19 Combination of two character cells to form new font (in horizontal direction).

Microcontroller for monitor OSD and auto-sync applications

PCE84C886

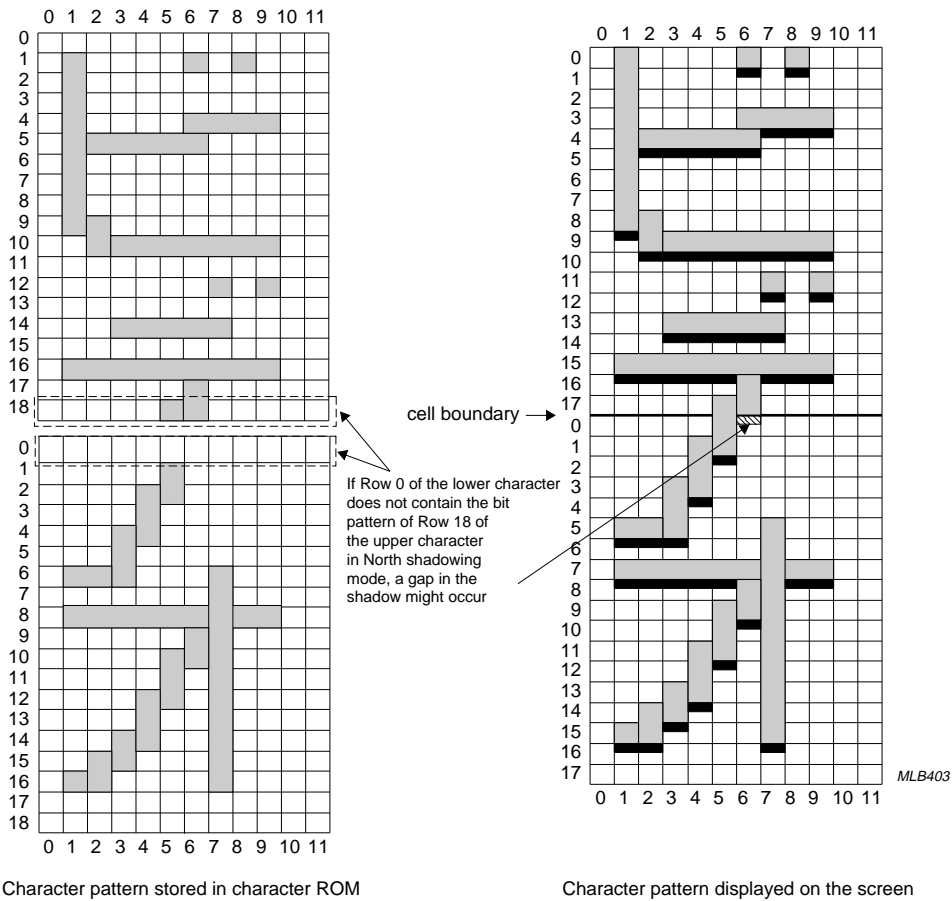

Fig.20 Combination of two character fonts in a vertical direction - with gap.

Microcontroller for monitor OSD and auto-sync applications

PCE84C886

12 OSD CONTROL REGISTERS

The functions of the OSD are controlled by Derivative Registers 22, 23, 33, 34, 35, 36 and 37. An overview of the function of each register is given in Table 16. A full description of each register is given in Sections 12.1 to 12.7.

Table 16 OSD Control Registers overview

REGISTER NAME	REGISTER NUMBER	ADDRESS (HEX)	FUNCTION
CON1	Derivative Register 22	22	This register is used to enable PWM8; the I ² C-bus lines; the ADC channels and the VOW0 and VOW1 lines.
CON2	Derivative Register 23	23	This register selects the output polarity of the PWM outputs and also enables and selects the VSYNCN interrupt.
CON3	Derivative Register 33	33	This register selects the blinking frequency and the active ratio of the blinking frequency for the OSD.
CON4	Derivative Register 34	34	This register selects the 4 display modes; the active state of the HSYNCN and VSYNCN inputs and the output polarity of the FB and VOW0 to VOW2 outputs. It also enables/disables the OSD clock.
VPOS	Derivative Register 35	35	This register selects the vertical starting position of the display row.
HPOS	Derivative Register 36	36	This register selects the horizontal starting position of the display row.
FRC	Derivative Register 37	37	This register selects the background colour in Frame shadowing mode.

Microcontroller for monitor OSD and auto-sync applications

PCE84C886

12.1 Derivative Register 22

This register is used to enable PWM8; the I²C-bus lines; the ADC channels and the VOW0 and VOW1 lines.

Table 17 Derivative Register 22

7	6	5	4	3	2	1	0
PWM8E	SCLE	SDAE	ADC2E	ADC1E	ADC0E	VOW1E	VOW0E

Table 18 Description of Derivative Register 22 bits

BIT	SYMBOL	DESCRIPTION
7	PWM8E	Pulse Width Modulated output PWM8 enable bit. When PWM8E = 1; pin 9 is selected as an output for PWM8. When PWM8E = 0; pin 9 is selected as Derivative Port line DP13 and the PWM function is disabled.
6	SCLE	I ² C-bus clock enable bit. When SCLE = 1; pin 39 is selected as the I ² C-bus clock line. When SCLE = 0; pin 39 is selected as Derivative Port line DP21 and the I ² C-bus function is disabled.
5	SDAE	I ² C-bus data enable bit. When SDAE = 1; pin 40 is selected as the I ² C-bus data line. When SDAE = 0; pin 40 is selected as Derivative Port line DP20 and the I ² C-bus function is disabled.
4	ADC2E	ADC Channel 2 enable bit. When ADC2E = 1; Channel 2 is enabled. When ADC2E = 0; Channel 2 is disabled.
3	ADC1E	ADC Channel 1 enable bit. When ADC1E = 1; Channel 1 is enabled. When ADC1E = 0; Channel 1 is disabled.
2	ADC0E	ADC Channel 0 enable bit. When ADC0E = 1; Channel 0 is enabled. When ADC0E = 0; Channel 0 is disabled.
1	VOW1E	VOW1E enable bit, When VOW1E = 1; pin 3 is selected as the VOW1 output. When VOW1E = 0; pin 3 is selected as Derivative Port line DP22 and the VOW function is disabled.
0	VOW0E	VOW0E enable bit, When VOW0E = 1; pin 4 is selected as the VOW0 output. When VOW0E = 0; pin 4 is selected as Derivative Port line DP23 and the VOW function is disabled.

Microcontroller for monitor OSD and auto-sync applications

PCE84C886

12.2 Derivative Register 23

This register selects the output polarity of the PWM outputs and also enables and selects the VSYNCN interrupt.

Table 19 Derivative Register 23

7	6	5	4	3	2	1	0
VINT	VIEN	–	–	–	P8LVL	P7LVL	P6LVL

Table 20 Description of Derivative Register 23 bits

BIT	SYMBOL	DESCRIPTION
7	VINT	VSYNCN/SIO interrupt indication bit. This bit indicates which of the two possible interrupt sources, the Vsync signal (at the VSYNCN pin) or the SIO, generated the interrupt. The interrupt causes the program to jump to the I ² C interrupt subroutine at address 05H. If VINT = 1; then the interrupt was generated by Vsync. If VINT = 0; then the I ² C-bus generated the interrupt. This bit must be reset after the interrupt has been serviced, otherwise additional unwanted interrupts will be generated.
6	VIEN	VSYNCN interrupt enable bit. When the SIO interrupt is enabled and VIEN = 1; the Vsync signal (at the VSYNCN pin) will generate an interrupt to the CPU. The VSYNCN interrupt is edge-triggered and can be selected to become active, using the Vp bit in Register 34, on the rising or falling edge of the Vsync signal. In order to generate a VSYNCN interrupt at the start of the vertical back tracing period, the Vp bit must be set correctly; see Section 12.4. The VSYNCN interrupt and the I ² C-bus interrupt share the same interrupt vector.
5	–	These three bits are reserved.
4	–	
3	–	
2	P8LVL	Polarity select bit for output PWM8. When P8LVL = 0; the PWM8 output is not inverted. When P8VL = 1; the PWM8 output is inverted.
1	P7LVL	Polarity select bit for outputs PWM0 to PWM3. When P7LVL = 0; the PWM outputs are not inverted. When P7LVL = 1; the PWM outputs are inverted.
0	P6LVL	Polarity select bit for outputs PWM4 to PWM7. When P6LVL = 0; the PWM outputs are not inverted. When P6LVL = 1; the PWM outputs are inverted.

Microcontroller for monitor OSD and auto-sync applications

PCE84C886

12.3 Derivative Register 33

Derivative Register 33 controls the character blinking functions.

Table 21 Derivative Register 33

7	6	5	4	3	2	1	0
–	–	–	–	BR1	BR0	BF1	BF0

Table 22 Description of Derivative Register 33 bits

BIT	SYMBOL	DESCRIPTION
7	–	These 4 bits are reserved.
6	–	
5	–	
4	–	
3	BR1	Blinking active ratio select bits. These two bits allow one from a choice of three active blinking ratios to be selected; see Table 23.
2	BR0	
1	BF1	Blinking frequency select bits. These two bits allow one from a choice of four blinking frequencies to be selected; see Table 24.
0	BF0	

Table 23 Selection of Blinking active ratio

BR1	BR0	ACTIVE RATIO
0	0	3 : 1; this is also the default setting.
0	1	1 : 1
1	0	1 : 3
1	1	reserved

Table 24 Selection of Blinking frequency

BF1	BF0	BLINKING FREQUENCY (Hz)
0	0	$\frac{f_{Vsync}}{16}$
0	1	$\frac{f_{Vsync}}{32}$
1	0	$\frac{f_{Vsync}}{64}$
1	1	$\frac{f_{Vsync}}{128}$; this is also the default setting.

Microcontroller for monitor OSD and auto-sync applications

PCE84C886

12.3.1 THE DISPLAY OF SPACE AND CARRIAGE RETURN CHARACTERS IN THE 4 DISPLAY MODES

Figures 22 to 25 show the display of Space and Carriage Return Characters in the 4 display modes, with the Blinking function ON and OFF.

- Mode 0: No background mode. Both the Space Code and the Carriage Return Code are displayed as transparent (no bit) patterns, with the video signal as the background. This is shown in Fig.22.
- Mode 1: North shadowing mode. Both codes are displayed in the same manner as for Mode 0. This is shown in Fig.23.
- Mode 2: Box shadowing mode. The Space Code is displayed as a transparent pattern with selected background colour. This will also be the background colour of the character following the Space Code. However, when the Space Code is used as an end bit, it will be displayed as a transparent pattern superimposed on the video (see Fig.29). The Carriage Return Code in Mode 2 is also displayed as a transparent pattern superimposed on the video signal.
- Mode 3: Frame shadowing mode. The Space Code and the Carriage Return Code are both displayed as transparent patterns with background colour (see Fig.25).

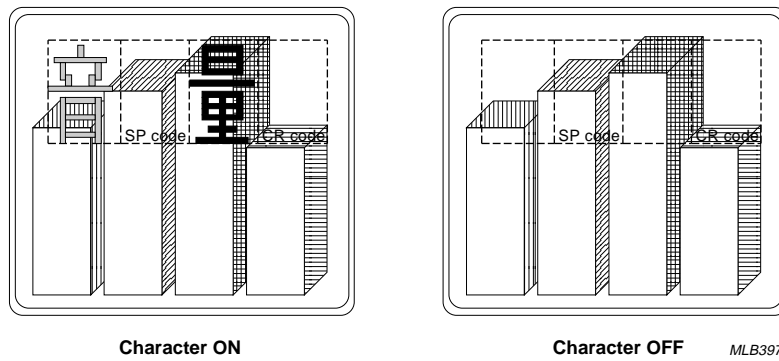

Fig.22 Blinking in No background (superimpose) mode.

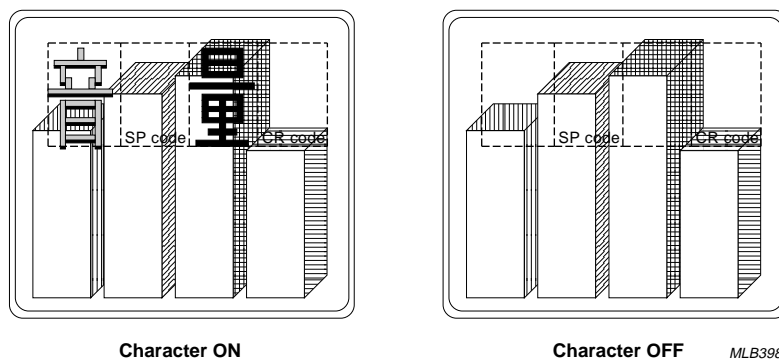
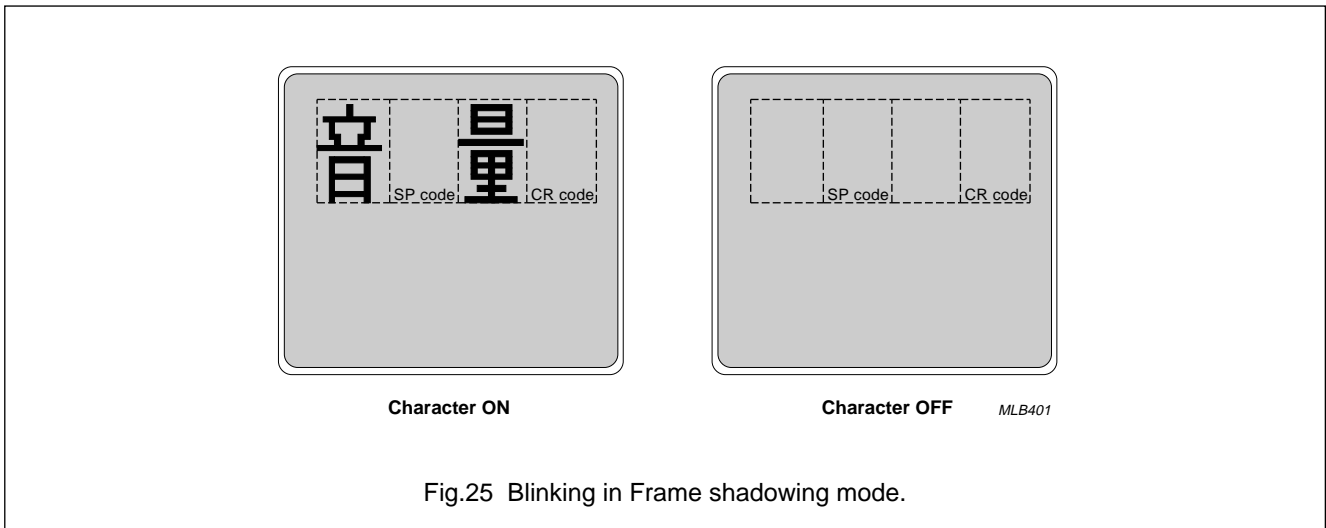
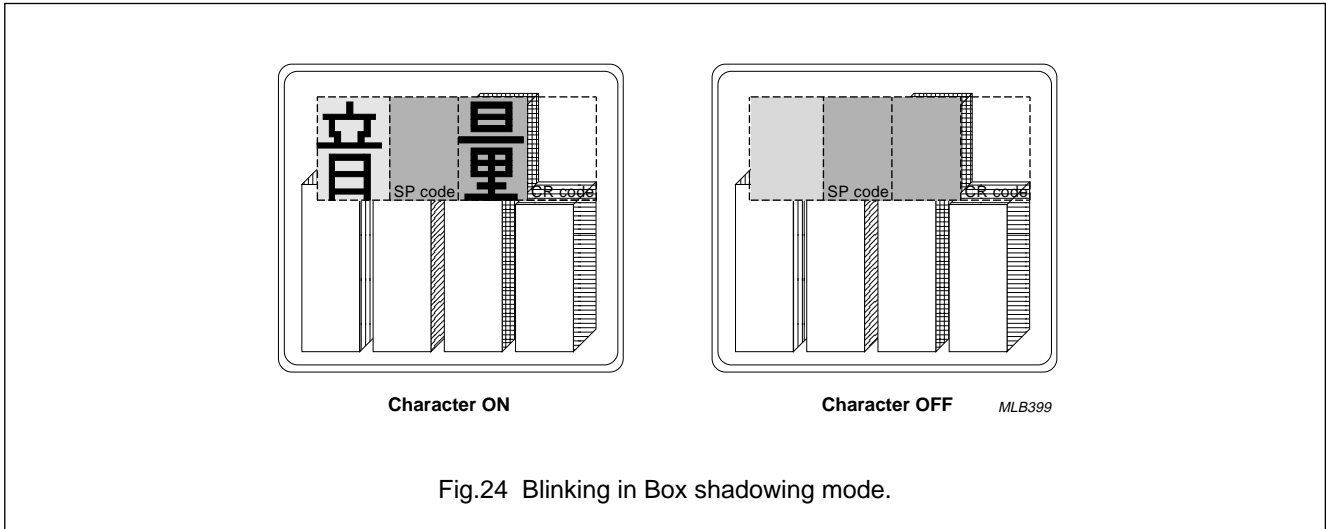

Fig.23 Blinking in North shadowing mode.

Microcontroller for monitor OSD and auto-sync applications

PCE84C886



Microcontroller for monitor OSD and auto-sync applications

PCE84C886

12.4 Derivative Register 34

This register selects the 4 display modes; the active state of the signal at the HSYN CN and VSYN CN inputs and the output polarity of the FB and VOW0 to VOW2 outputs. It also enables/disables the OSD clock.

Table 25 Derivative Register 34

7	6	5	4	3	2	1	0
–	–	S1	S0	Hp	Vp	Bp	EN

Table 26 Description of Derivative Register 34 bits

BIT	SYMBOL	DESCRIPTION
7	–	These two bits are reserved.
6	–	
5	S1	Display mode select bits on a frame basis; see Table 27.
4	S0	
3	Hp	HSYN CN signal polarity control bit. When Hp = 0, the active level of the signal at the HSYN CN input is LOW; this is also the default state. When Hp = 1, the active level of the signal at the HSYN CN input is HIGH. See Fig.15.
2	Vp	VSYN CN signal polarity control bit. When Vp = 0, the active level of the signal at the VSYN CN input is LOW; this is also the default state. When Vp = 1, the active level of the signal at the VSYN CN input is HIGH. See Fig.15.
1	Bp	Output polarity control bit for FB, VOW0, VOW1 and VOW2. When Bp = 1; these outputs are active HIGH; this is also the default state. When Bp = 0; these outputs are active LOW.
0	EN	OSD clock enable/disable bit. When EN = 1; the OSD clock is enabled. When EN = 0; the OSD clock is disabled.

Table 27 Selection of Display Modes

S1	S0	DISPLAY MODE
0	0	Mode 0: No background (superimpose) mode. The OSD characters are superimposed on the monitor video signals. See Fig.26.
0	1	Mode 1: North shadowing mode. The characters' shadows are generated as if a light source was placed North of the character (see Fig.27). Character shadowing only appears within the cell boundary. Consequently, if Row 18 contains a bit pattern then North shadowing will not be shown on the screen (see Fig.19). The depth of shadow displayed is dependent upon the character size. Characters with sizes of 1H/1V; 1H/2V and 1H/3V have a depth of shadow equivalent to 1 scan line whereas a character of size 1H/4V has a depth of shadow equivalent to 2 scan lines. Examples of characters with North shadowing, for the 4 character sizes, are shown in Fig.28.
1	0	Mode 2: Box shadowing mode. A background dot matrix of 12 × 18 bits surrounds the character font; where there is no foreground dot a background dot is displayed (see Fig.29).
1	1	Mode 3: Frame shadowing mode. A background colour fills the whole screen when no bit patterns are being displayed (see Fig.30). 1 of 8 background colours can be selected using Derivative Register 37; the default background colour is blue.

Microcontroller for monitor OSD
and auto-sync applications

PCE84C886

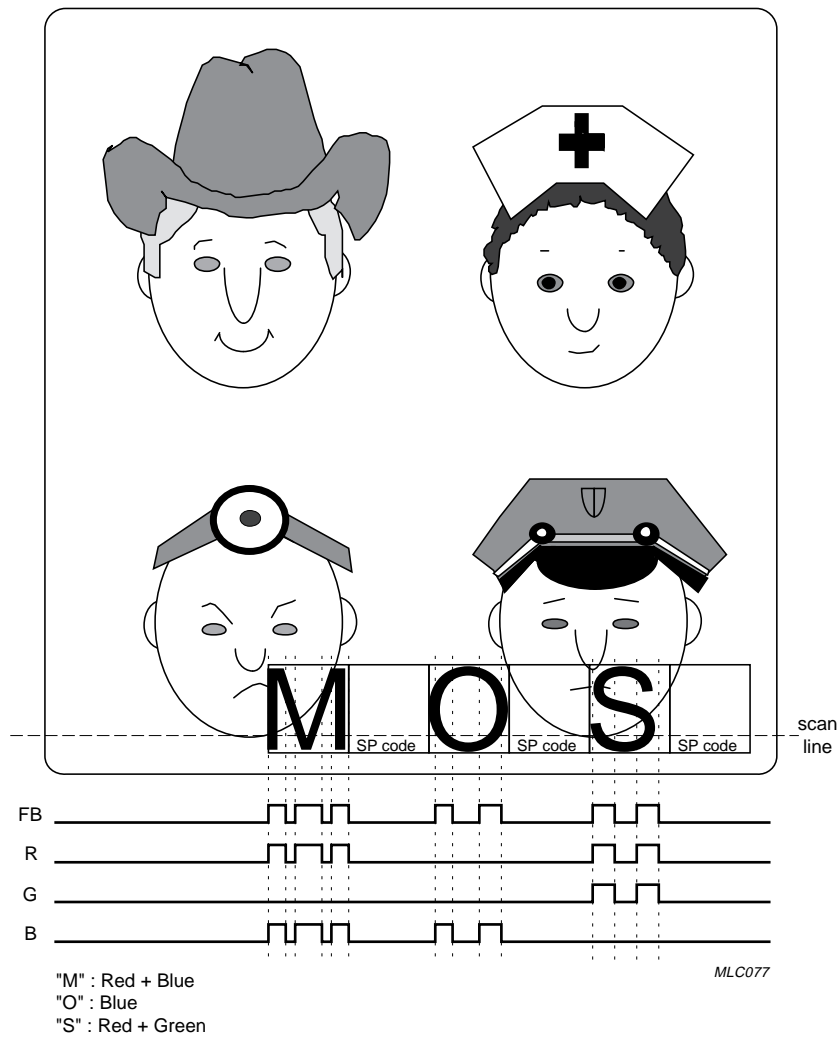

Fig.26 Mode 0: No background (superimpose) mode.

Microcontroller for monitor OSD
and auto-sync applications

PCE84C886

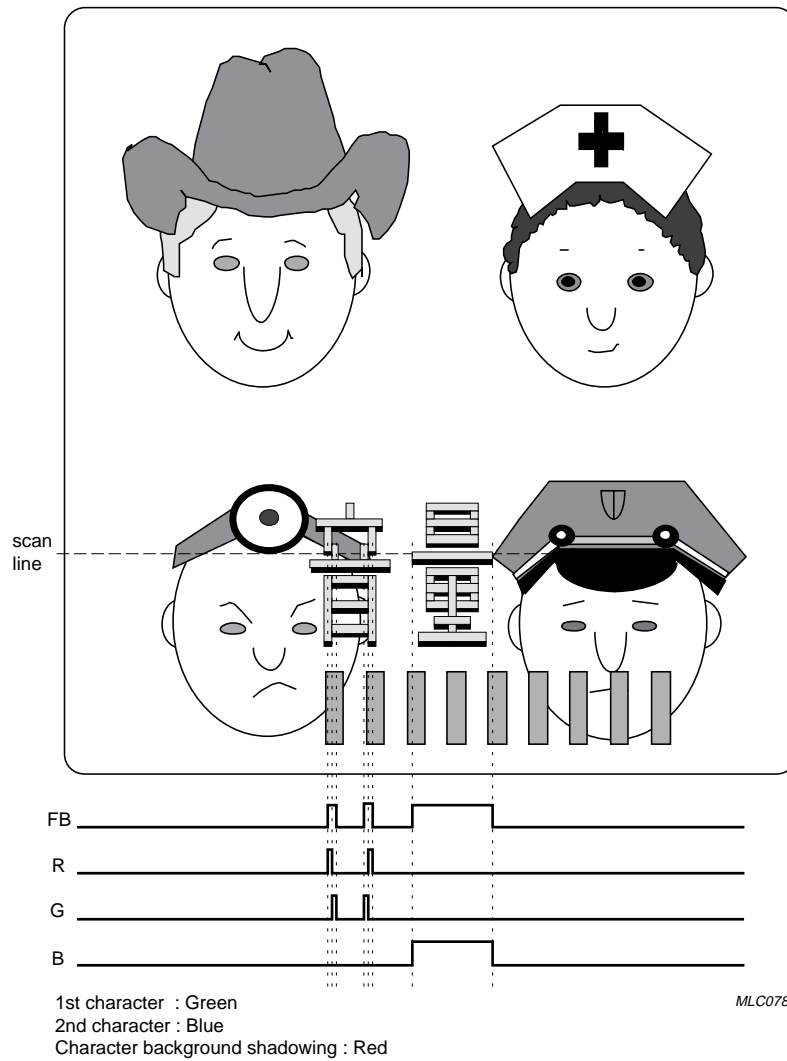
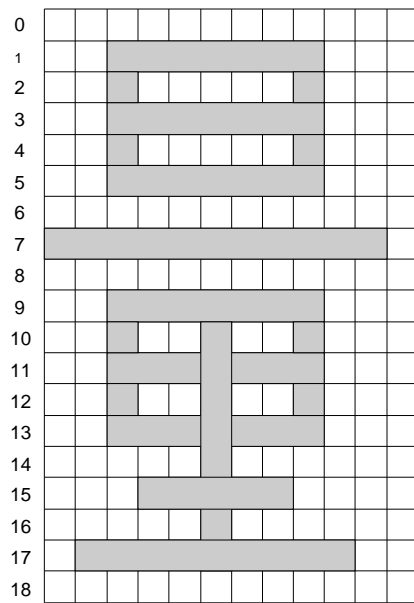

Fig.27 Mode 1: North shadowing background mode.

Microcontroller for monitor OSD
and auto-sync applications

PCE84C886



(a) Character designed in character ROM

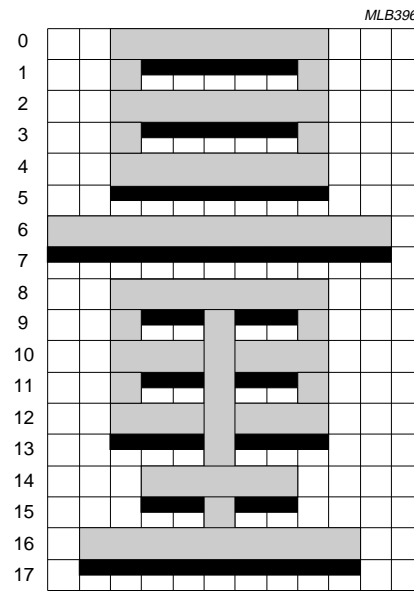

(b) 1H/2V or 1H/4V character displayed on the screen

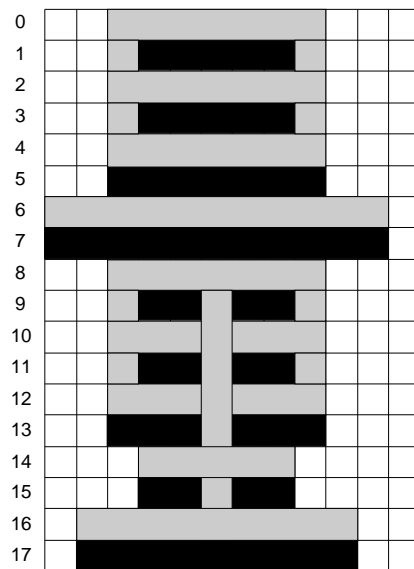

(c) 1H/1V character displayed on the screen

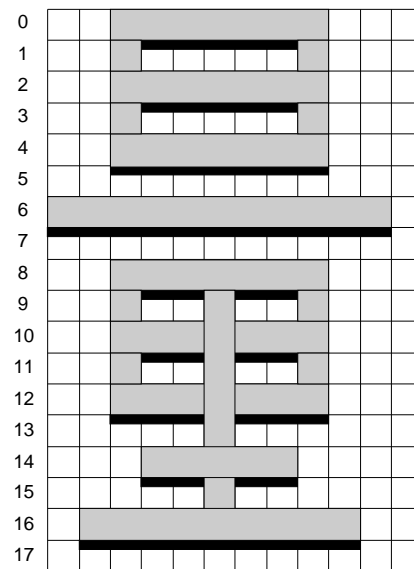

(d) 1H/3V character displayed on the screen

Fig.28 Example of North shadowing mode.

Microcontroller for monitor OSD
and auto-sync applications

PCE84C886

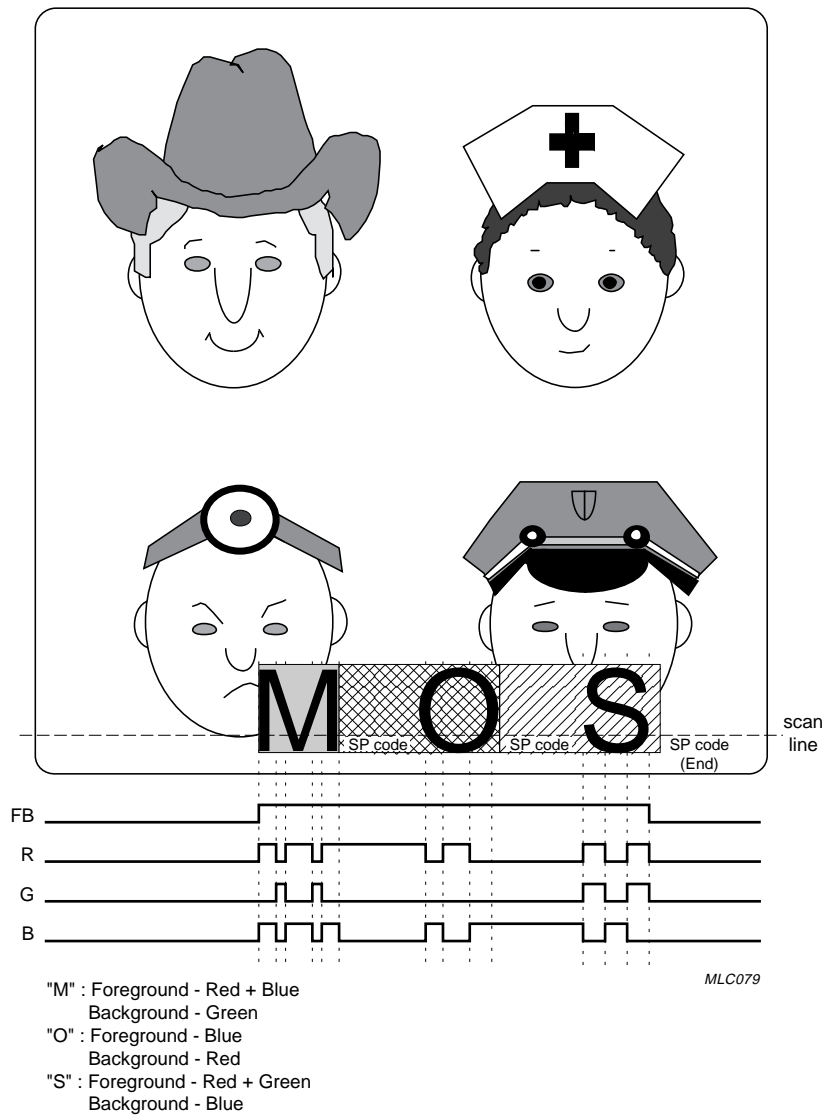

Fig.29 Mode 2: Box shadowing (background) mode.

Microcontroller for monitor OSD
and auto-sync applications

PCE84C886

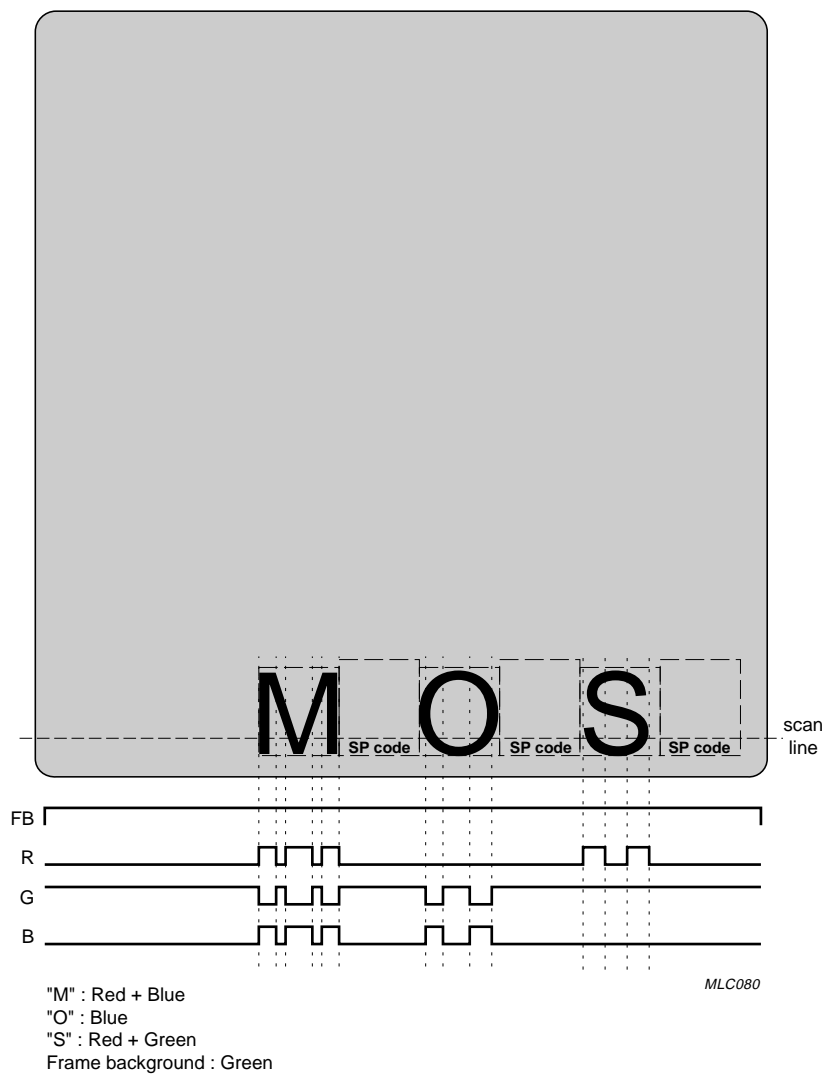

Fig.30 Mode 3: Frame shadowing mode.

Microcontroller for monitor OSD and auto-sync applications

PCE84C886

12.5 Derivative Register 35

Derivative Register 35 selects the vertical starting position of the display row.

Table 28 Derivative Register 35

7	6	5	4	3	2	1	0
–	–	V5	V4	V3	V2	V1	V0

Table 29 Description of Derivative Register 35 bits.

BIT	SYMBOL	DESCRIPTION
7	–	These 2 bits are reserved.
6	–	
5	V5	These 6 bits enable 1 of 64 vertical start positions to be selected for the display row. The vertical starting position is calculated as follows: $VP = [4 \times (V5 \rightarrow V0)] \times \text{horizontal scan lines}$ Where $(V5 \rightarrow V0)$ is the decimal value of the contents of Register 35; $(V5 \rightarrow V0) \geq 0$.
4	V4	
3	V3	
2	V2	
1	V1	
0	V0	

12.6 Derivative Register 36

Derivative Register 36 selects the horizontal starting position of the display row.

Table 30 Derivative Register 36

7	6	5	4	3	2	1	0
–	–	H5	H4	H3	H2	H1	H0

Table 31 Description of Derivative Register 36 bits

BIT	SYMBOL	DESCRIPTION
7	–	These 2 bits are reserved.
6	–	
5	H5	These 6 bits enable 1 of 64 horizontal start positions to be selected for the display row. The horizontal starting position is calculated as follows: $HP = [4 \times (H5 \rightarrow H0) + 5] \times \text{OSD clock}$ Where $(H5 \rightarrow H0)$ is the decimal value of the contents of Register 36; $(H5 \rightarrow H0) \geq 10$.
4	H4	
3	H3	
2	H2	
1	H1	
0	H0	

Microcontroller for monitor OSD and auto-sync applications

PCE84C886

12.7 Derivative Register 37

Derivative Register 37 selects the background colour when the OSD is in Frame shadowing mode.

Table 32 Derivative Register 37

7	6	5	4	3	2	1	0
–	–	–	–	–	FRR	FRG	FRB

Table 33 Description of Derivative Register 37 bits

BIT	SYMBOL	DESCRIPTION
7	–	These 5 bits are reserved.
6	–	
5	–	
4	–	
3	–	
2	FRR	These three bits are used to select the background colour in Frame shadowing mode; see Table 34. The default colour is blue.
1	FRG	
0	FRB	

Table 34 Selection of Background colour

FRR (RED)	FRG (GREEN)	FRB (BLUE)	COLOUR
0	0	0	black
0	0	1	blue
0	1	0	green
0	1	1	cyan
1	0	0	red
1	0	1	magenta
1	1	0	yellow
1	1	1	white

Microcontroller for monitor OSD and auto-sync applications

PCE84C886

13 TO FORMAT THE OSD

13.1 Number of characters per row

The number of characters per row is a function of character width. The width of the character displayed is only dependent upon the value held in the 7-bit programmable counter (PLLCN) and is not affected by a change in horizontal resolution (any change in f_{Hsync} will be reflected by a linear change in the frequency of the OSD clock).

The maximum number of characters per row can be determined by calculating the number of OSD clock pulses that occur during the Hsync active period and dividing the result by the number of horizontal dots in the character matrix (which is 12). If Hsync is assumed to be active for 85% of its cycle period then the maximum number of characters per row (N) can be calculated as follows:

$$N = \frac{0.85 \times f_{OSD}}{12 \times f_{Hsync}}$$

13.2 Number of rows per frame

The number of rows per frame is a function of character height and the spacing between the rows of characters.

The height of a character displayed on the screen is determined by the number of visible scan lines per frame and the character size. The number of scan lines is dependent upon the resolution of the monitor; character size is selected by the user (see Section 10.1.2). The PCE84C886 also provides a choice of four inter-line spaces: 0H, 4H, 8H and 12H (see Section 10.1.2).

If the inter-line spacing is assumed to be zero then the number of rows per frame (R) can be calculated by dividing the number of visible scan lines (SL) by the character size (CS) and dividing the result by the number of vertical dots in the character matrix (which is 18). This can be expressed mathematically as follows:

$$R = \frac{SL}{18 \times CS}$$

Table 35 shows the number of rows per frame for different horizontal resolutions.

13.3 Character size selection for different display resolutions

To cater for the variable display resolutions (640 x 400, 640 x 480, 800 x 600, 1024 x 768 and 1280 x 1024) of auto-sync monitors, the PCE84C886 offers a choice of 4 different character sizes: 1H/1V, 1H/2V, 1H/3V and 1H/4V. This allows the height of displayed characters to be of similar size even when the monitors resolution is changed (see Table 35).

Table 35 Recommended character size selection for different display resolutions

RESOLUTION	CHARACTER SIZE	ROWS/FRAME
640 × 400	1H/2V	11
640 × 480	1H/2V	13
800 × 600	1H/3V	11
1024 × 768	1H/4V	10
1280 × 1024	1H/4V	14

Microcontroller for monitor OSD and auto-sync applications

PCE84C886

14 8-BIT COUNTER (T3)

One application for this counter is in the frequency measurement of the Hsync signal.

The block diagram of the 8-bit counter is shown in Fig.31. A Schmitt trigger is used at the input for noise rejection and also to shape the input signal into a square wave. The rising edge of the input increments the ripple counter by '1'. The minimum distance between the rising edges of two successive input pulses is 10 μs; the minimum pulse width (HIGH-to-LOW level) of the input is 1 μs.

T3 may be read using the instruction MOV A, D24 (where D24 is Derivative Register 24). To ensure that a valid read operation has been carried out, the counter needs to be read at least twice. As soon as data is read, the counter is reset to zero. The counter is also reset to zero on overflow or Power-on-reset.

The piggy-back device to be used with the PCE84C886 is the PCA84C841B. As this piggy-back device is also used with other microcontrollers in the 84CXXXA family, in order to prevent contention between the T3 pin of the PCE84C886 and the corresponding pin P13 used by the other microcontrollers, when writing to Port 1, P13 must be set to a logic 1 (this port line is not available in the PCE84C886).

15 I²C-BUS INTERFACE

The PCE84C886 has an on-chip I²C-bus interface that can be used in master or slave mode. Full details of the I²C-bus are given in the document "The I²C-bus and how to use it". This document may be ordered using the code 9398 393 40011.

The I²C-bus interface lines SDA and SCL share the same pins as Derivative Port lines DP20 and DP21 respectively. Selection of the pin function as either an I²C-bus line or a Derivative Port line is achieved using the SDAE and SCLE bits in Derivative Register 22 (see Section 12.1). Only port Option 2 is available for both of these pins.

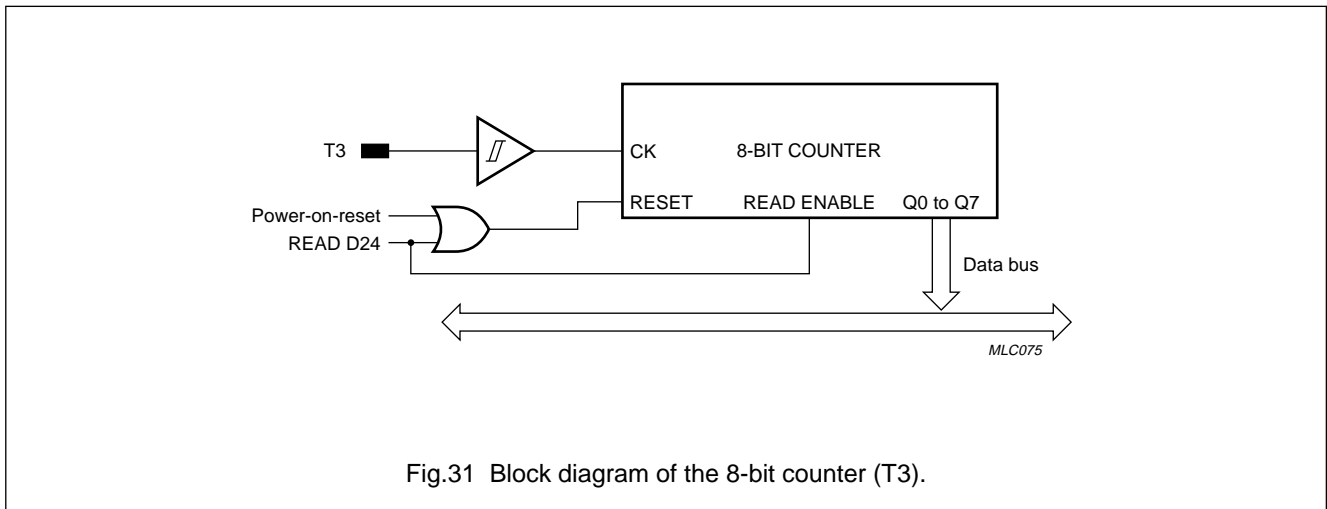

Fig.31 Block diagram of the 8-bit counter (T3).

Microcontroller for monitor OSD and auto-sync applications

PCE84C886

16 OUTPUT PORTS

Each I/O port line may be individually configured using one of three mask options. The three I/O mask options are specified below:

Option 1 Standard input/output with switched pull-up current source; this is shown in Fig.32.

Option 2 Input/output with Open drain output; this is shown in Fig.33.

Option 3 Push-pull output; this is shown in Fig.34.

The state of each output port after a Power-on-reset can also be selected using the mask options. All port mask options are given in Section 16.1.

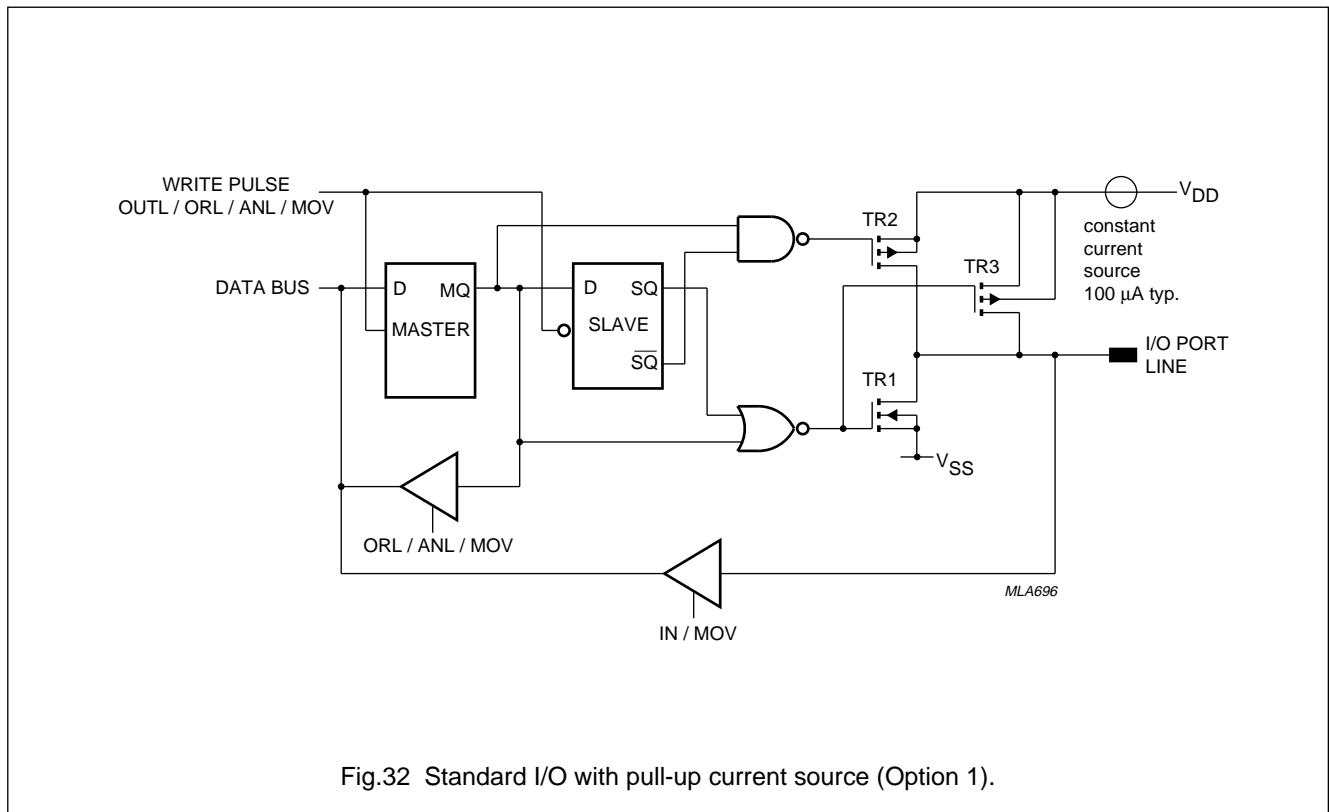

Fig.32 Standard I/O with pull-up current source (Option 1).

Microcontroller for monitor OSD and auto-sync applications

PCE84C886

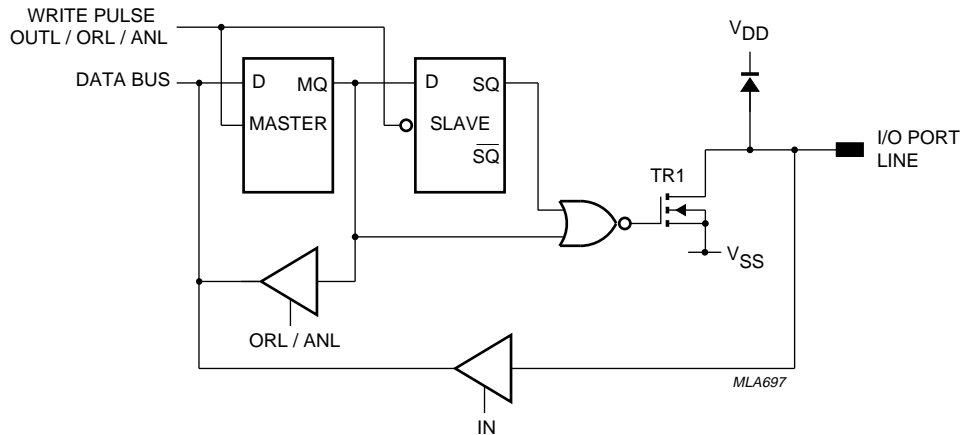

Fig.33 I/O with open-drain output (Option 2).

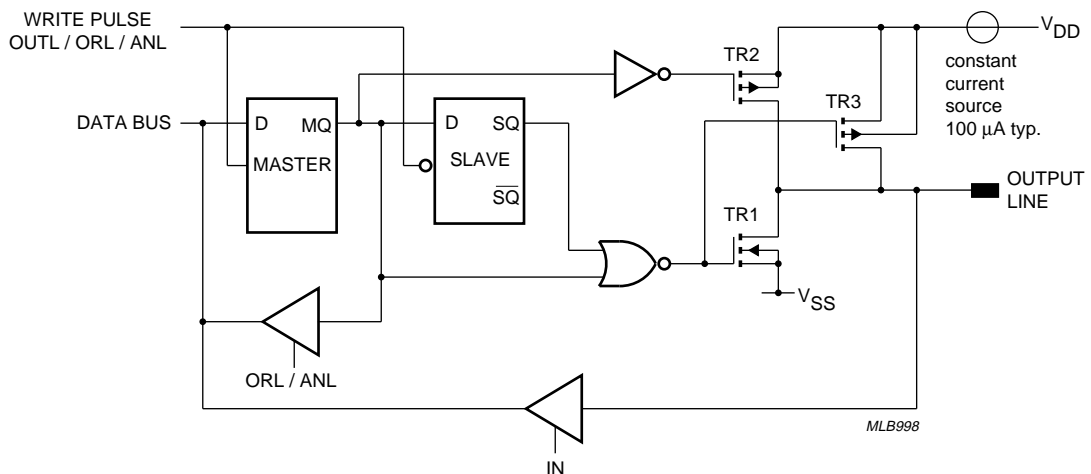

Fig.34 Push-pull output (Option 3).

Microcontroller for monitor OSD and auto-sync applications

PCE84C886

16.1 Mask options

Table 36 lists the port mask options for the PCE84C886. Table 37 is intended for customer use when ordering the device.

Table 36 Port options

PORT	PIN	OPTION	
		CONFIGURATION	RESET STATE
P00	13	1, 2 or 3	HIGH or LOW
P01	14	1, 2 or 3	HIGH or LOW
P02	15	1, 2 or 3	HIGH or LOW
P03	16	1, 2 or 3	HIGH or LOW
P04	17	1, 2 or 3	HIGH or LOW
P05	18	1, 2 or 3	HIGH or LOW
P06	19	1, 2 or 3	HIGH or LOW
P07	20	1, 2 or 3	HIGH or LOW
P10	7	1, 2 or 3	HIGH or LOW
P11	8	1, 2 or 3	HIGH or LOW
P12	10	1, 2 or 3	HIGH or LOW
P14	12	1, 2 or 3	HIGH or LOW
DP00	29	1, 2 or 3	HIGH or LOW
DP01	28	1, 2 or 3	HIGH or LOW
DP02	27	1, 2 or 3	HIGH or LOW
DP03	26	1, 2 or 3	HIGH or LOW
DP04	25	1, 2 or 3	HIGH or LOW
DP05	24	1, 2 or 3	HIGH or LOW
DP06	23	1, 2 or 3	HIGH or LOW
DP07	22	1, 2 or 3	HIGH or LOW
DP10	38	1, 2 or 3	HIGH or LOW
DP11	37	1, 2 or 3	HIGH or LOW
DP12	36	1, 2 or 3	HIGH or LOW
DP13	9	1, 2 or 3	HIGH or LOW
DP20	40	2	HIGH
DP21	39	2	HIGH
DP22	3	1, 2 or 3	HIGH or LOW
DP23	4	1, 2 or 3	HIGH or LOW
FB	1	2 or 3	HIGH or LOW
VOW2	2	2 or 3	HIGH or LOW

Table 37 Customer selected mask options

PORT	PIN	OPTION	
		CONFIGURATION	RESET STATE
P00	13		
P01	14		
P02	15		
P03	16		
P04	17		
P05	18		
P06	19		
P07	20		
P10	7		
P11	8		
P12	10		
P14	12		
DP00	29		
DP01	28		
DP02	27		
DP03	26		
DP04	25		
DP05	24		
DP06	23		
DP07	22		
DP10	38		
DP11	37		
DP12	36		
DP13	9		
DP20	40	2	S
DP21	39	2	S
DP22	3		
DP23	4		
FB	1		
VOW2	2		

Microcontroller for monitor OSD and auto-sync applications

PCE84C886

17 DERIVATIVE REGISTERS

There are 30 Derivative Registers in the PCE84C886. The Derivative Port I/O registers are located at addresses 00 to 05H. When DP0TR, DP1TR and DP2TR are read the data is read directly from the pin. However, when DP0R, DP1R and DP2R are read the data is read from the port latch (see Figs 32 to 34 for the port configuration).

Table 38 Register map (see note 1)

ADDR (HEX)	REG	7	6	5	4	3	2	1	0	R/W
00	DP0TR	DP07 (X)	DP06 (X)	DP05 (X)	DP04 (X)	DP03 (X)	DP02 (X)	DP01 (X)	DP00 (X)	R
01	DP1TR	– (X)	– (X)	– (X)	– (X)	DP13 (X)	DP12 (X)	DP11 (X)	DP10 (X)	R
02	DP2TR	– (X)	– (X)	– (X)	– (X)	DP23 (X)	DP22 (X)	DP21 (X)	DP20 (X)	R
03	DP0R	DP07 (1)	DP06 (1)	DP05 (1)	DP04 (1)	DP03 (1)	DP02 (1)	DP01 (1)	DP00 (1)	RW
04	DP1R	– (X)	– (X)	– (X)	– (X)	DP13 (1)	DP12 (1)	DP11 (1)	DP10 (1)	RW
05	DP2R	– (X)	– (X)	– (X)	– (X)	DP23 (1)	DP22 (1)	DP21 (1)	DP20 (1)	RW
10	PWM0	– (X)	PWM06 (0)	PWM05 (0)	PWM04 (0)	PWM03 (0)	PWM02 (0)	PWM01 (0)	PWM00 (0)	RW
11	PWM1	– (X)	PWM16 (0)	PWM15 (0)	PWM14 (0)	PWM13 (0)	PWM12 (0)	PWM11 (0)	PWM10 (0)	RW
12	PWM2	– (X)	PWM26 (0)	PWM25 (0)	PWM24 (0)	PWM23 (0)	PWM22 (0)	PWM21 (0)	PWM20 (0)	RW
13	PWM3	– (X)	PWM36 (0)	PWM35 (0)	PWM34 (0)	PWM33 (0)	PWM32 (0)	PWM31 (0)	PWM30 (0)	RW
14	PWM4	– (X)	– (X)	PWM45 (0)	PWM44 (0)	PWM43 (0)	PWM42 (0)	PWM41 (0)	PWM40 (0)	RW
15	PWM5	– (X)	– (X)	PWM55 (0)	PWM54 (0)	PWM53 (0)	PWM52 (0)	PWM51 (0)	PWM50 (0)	RW
16	PWM6	– (X)	– (X)	PWM65 (0)	PWM64 (0)	PWM63 (0)	PWM62 (0)	PWM61 (0)	PWM60 (0)	RW
17	PWM7	– (X)	– (X)	PWM75 (0)	PWM74 (0)	PWM73 (0)	PWM72 (0)	PWM71 (0)	PWM70 (0)	RW
18	PWM8L	– (X)	PWM86L (0)	PWM85L (0)	PWM84L (0)	PWM83L (0)	PWM82L (0)	PWM81L (0)	PWM80L (0)	RW
19	PWM8H	– (X)	PWM86H (0)	PWM85H (0)	PWM84H (0)	PWM83H (0)	PWM82H (0)	PWM81H (0)	PWM80H (0)	RW
20	ADCCN	– (X)	ADCS1 (0)	ADCS0 (0)	DAC3 (0)	DAC2 (0)	DAC1 (0)	DAC0 (0)	COMP ⁽²⁾ (0)	RW
21	PWME	PWM7E (0)	PWM6E (0)	PWM5E (0)	PWM4E (0)	PWM3E (0)	PWM2E (0)	PWM1E (0)	PWM0E (0)	RW
22	CON1	PWM8E (0)	SCLE (0)	SDAE (0)	ADCE2 (0)	ADCE1 (0)	ADCE0 (0)	VOW1E (0)	VOW0E (0)	RW

Microcontroller for monitor OSD and auto-sync applications

PCE84C886

ADDR (HEX)	REG	7	6	5	4	3	2	1	0	R/W
23	CON2	VINT (0)	VIEN (0)	– (X)	– (X)	– (X)	P8LVL (0)	P7LVL (0)	P6LVL (0)	RW
24	T3CON	T3B7 (0)	T3B6 (0)	T3B5 (0)	T3B4 (0)	T3B3 (0)	T3B2 (0)	T3B1 (0)	T3B0 (0)	R
25	PLLCN	– (X)	PLL6 (0)	PLL5 (0)	PLL4 (0)	PLL3 (0)	PLL2 (0)	PLL1 (0)	PLL0 (0)	RW
30	DCRAR	– (X)	– (X)	DCRA5 (0)	DCRA4 (0)	DCRA3 (0)	DCRA2 (0)	DCRA1 (0)	DCRA0 (0)	RW
31	DCRTR	– (X)	– (X)	– (X)	– (X)	DCRT3 (1)	DCRT2 (1)	DCRT1 (1)	DCRT0 (1)	W
32	DCRCR	– (X)	– (X)	DCRC5 (1)	DCRC4 (1)	DCRC3 (1)	DCRC2 (1)	DCRC1 (1)	DCRC0 (1)	W
33	CON3	– (X)	– (X)	– (X)	– (X)	BR1 (0)	BR0 (0)	BF1 (1)	BF0 (1)	RW
34	CON4	– (X)	– (X)	S1 (0)	S0 (0)	Hp (0)	Vp (0)	Bp (1)	EN (0)	RW
35	VPOS	– (X)	– (X)	V5 (1)	V4 (1)	V3 (1)	V2 (1)	V1 (1)	V0 (1)	W
36	HPOS	– (X)	– (X)	H5 (0)	H4 (0)	H3 (0)	H2 (0)	H1 (0)	H0 (0)	W
37	FRC	– (X)	– (X)	– (X)	– (X)	– (X)	FRR (0)	FRG (0)	FRB (1)	W

Notes

- Values within parenthesis show the bit state after a reset operation. 'X' denotes an undefined state.
- This bit is Read only.

18 LIMITING VALUES

In accordance with the Absolute Maximum Rating System (IEC 34).

SYMBOL	PARAMETER	MIN.	MAX.	UNIT
V_{DD}	supply voltage	–0.3	+8.0	V
V_I	input voltage on any pin with respect to ground (V_{SS})	–0.3	$V_{DD} + 0.3$	V
I_{OH}	maximum source current for all port lines	–	–10.0	mA
I_{OL}	maximum sink current for all port lines	–	30.0	mA
P_{tot}	total power dissipation	–	1	W
T_{amb}	operating ambient temperature	–25	+85	°C
T_{stg}	storage temperature	–55	+125	°C

Microcontroller for monitor OSD and auto-sync applications

PCE84C886

19 DC CHARACTERISTICS

$V_{DD} = 5\text{ V} \pm 10\%$; $V_{SS} = 0\text{ V}$; $T_{amb} = -25\text{ to }+85\text{ }^{\circ}\text{C}$; all voltages with respect to V_{SS} ; unless otherwise specified.

SYMBOL	PARAMETER	CONDITIONS	MIN.	TYP.	MAX.	UNIT
Supply						
V_{DD}	operating supply voltage		4.5	5.0	5.5	V
I_{DD}	operating supply current	$f_{OSD} = f_{xtal} = 10\text{ MHz}$	–	5	10	mA
		$f_{OSD} = f_{xtal} = 6\text{ MHz}$	–	3.5	7	mA
		$f_{OSD} = \text{Stop}; f_{xtal} = 10\text{ MHz}$	–	3	6	mA
		$f_{OSD} = \text{Stop}; f_{xtal} = 6\text{ MHz}$	–	1.5	4	mA
V_{POR}	Power-on-reset voltage level		0.7	1.3	1.9	V
Ports P0, P1, DP0, DP1 and DP2 inputs						
V_{IL}	LOW level input voltage		0	–	$0.3V_{DD}$	V
V_{IH}	HIGH level input voltage		$0.7V_{DD}$	–	V_{DD}	V
I_{LI}	input leakage current	$V_{SS} < V_I < V_{DD}$	–	–	± 10	μA
Port P0 outputs						
V_{OL}	LOW level output voltage	$V_{DD} = 5\text{ V}; I_{OL} = 10\text{ mA}$	–	–	1.2	V
I_{OH1}	HIGH level pull-up output source current	$V_{DD} = 5\text{ V}; V_O = 0.7V_{DD}$	–40	–100	–	μA
		$V_{DD} = 5\text{ V}; V_O = V_{SS}$	–	–140	–400	μA
I_{OH2}	HIGH level push-pull output source current	$V_{DD} = 5\text{ V}; V_O = V_{DD} - 0.4\text{ V}$	–3.0	–7.0	–	mA
DP00/PWM0 to DP07/PWM7 as derivative ports						
I_{OL}	LOW level output sink current	$V_{DD} = 5\text{ V}; V_{OL} = 0.4\text{ V}$	5.0	12.0	–	mA
I_{OH1}	HIGH level pull-up output source current	$V_{DD} = 5\text{ V}; V_O = 0.7V_{DD}$	–40	–100	–	μA
		$V_{DD} = 5\text{ V}; V_O = V_{SS}$	–	–140	–400	μA
I_{OH2}	HIGH level push-pull output source current	$V_{DD} = 5\text{ V}; V_O = V_{DD} - 0.4\text{ V}$	–3.0	–7.0	–	mA
DP00/PWM0 to DP07/PWM7 as PWM outputs						
I_{OL}	LOW level output sink current	$V_{DD} = 5\text{ V}; V_{OL} = 0.4\text{ V}$	0.7	1.5	–	mA
I_{OH1}	HIGH level pull-up output source current	$V_{DD} = 5\text{ V}; V_O = 0.7V_{DD}$	–40	–100	–	μA
		$V_{DD} = 5\text{ V}; V_O = V_{SS}$	–	–140	–400	μA
I_{OH2}	HIGH level push-pull output source current	$V_{DD} = 5\text{ V}; V_O = V_{DD} - 0.4\text{ V}$	–0.7	–1.5	–	mA
P10 to P14, DP20 and DP21 outputs						
I_{OL}	LOW level output sink current	$V_{DD} = 5\text{ V}; V_{OL} = 0.4\text{ V}$	5.0	12.0	–	mA
I_{OH1}	HIGH level pull-up output source current	$V_{DD} = 5\text{ V}; V_O = 0.7V_{DD}$	–40	–100	–	μA
		$V_{DD} = 5\text{ V}; V_O = V_{SS}$	–	–140	–400	μA
I_{OH2}	HIGH level push-pull output source current	$V_{DD} = 5\text{ V}; V_O = V_{DD} - 0.4\text{ V}$	–3.0	–7.0	–	mA
DP20/SDA and DP21/SCL outputs						
I_{OL}	LOW level output sink current	$V_{DD} = 5\text{ V}; V_{OL} = 0.4\text{ V}$	3.0	–	–	mA
I_{OH1}	HIGH level pull-up output source current	$V_{DD} = 5\text{ V}; V_O = 0.7V_{DD}$	–40	–100	–	μA
		$V_{DD} = 5\text{ V}; V_O = V_{SS}$	–	–140	–400	μA
I_{OH2}	HIGH level push-pull output source current	$V_{DD} = 5\text{ V}; V_O = V_{DD} - 0.4\text{ V}$	–	–7.0	–	mA

Microcontroller for monitor OSD and auto-sync applications

PCE84C886

SYMBOL	PARAMETER	CONDITIONS	MIN.	TYP.	MAX.	UNIT
VOW1/DP22; VOW0/DP23 and DP13/PWM8 as derivative output ports						
I_{OL}	LOW level output sink current	$V_{DD} = 5\text{ V}; V_{OL} = 0.4\text{ V}$	5.0	12.0	–	mA
I_{OH1}	HIGH level pull-up output source current	$V_{DD} = 5\text{ V}; V_O = 0.7V_{DD}$	–40	–100	–	μA
		$V_{DD} = 5\text{ V}; V_O = V_{SS}$	–	–140	–400	μA
I_{OH2}	HIGH level push-pull output source current	$V_{DD} = 5\text{ V}; V_O = V_{DD} - 0.4\text{ V}$	–3.0	–7.0	–	mA
VOW1/DP22 and VOW0/DP23 as VOW outputs						
I_{OL}	LOW level output sink current	$V_{DD} = 5\text{ V}; V_{OL} = 0.4\text{ V}$	1.4	3.0	–	mA
I_{OH1}	HIGH level pull-up output source current	$V_{DD} = 5\text{ V}; V_O = 0.7V_{DD}$	–40	–100	–	μA
		$V_{DD} = 5\text{ V}; V_O = V_{SS}$	–	–140	–400	μA
I_{OH2}	HIGH level push-pull output source current	$V_{DD} = 5\text{ V}; V_O = V_{DD} - 0.4\text{ V}$	–1.4	–3.0	–	mA
DP13/PWM8 as PWM8 output						
I_{OL}	LOW level output sink current	$V_{DD} = 5\text{ V}; V_{OL} = 0.4\text{ V}$	1.4	3.0	–	mA
I_{OH1}	HIGH level pull-up output source current	$V_{DD} = 5\text{ V}; V_O = 0.7V_{DD}$	–40	–100	–	μA
		$V_{DD} = 5\text{ V}; V_O = V_{SS}$	–	–140	–400	μA
I_{OH2}	HIGH level push-pull output source current	$V_{DD} = 5\text{ V}; V_O = V_{DD} - 0.4\text{ V}$	–1.4	–3.0	–	mA
Outputs FB and VOW2						
I_{OL}	LOW level output sink current	$V_{DD} = 5\text{ V}; V_{OL} = 0.4\text{ V}$	1.4	3.0	–	mA
I_{OH1}	HIGH level pull-up output source current	$V_{DD} = 5\text{ V}; V_O = 0.7V_{DD}$	–40	–100	–	μA
		$V_{DD} = 5\text{ V}; V_O = V_{SS}$	–	–140	–400	μA
I_{OH2}	HIGH level push-pull output source current	$V_{DD} = 5\text{ V}; V_O = V_{DD} - 0.4\text{ V}$	–1.4	–3.0	–	mA
DP10/ADC0 to DP12/ADC2 as derivative output ports						
I_{OL}	LOW level output sink current	$V_{DD} = 5\text{ V}; V_{OL} = 0.4\text{ V}$	5.0	12.0	–	mA
I_{OH1}	HIGH level pull-up output source current	$V_{DD} = 5\text{ V}; V_O = 0.7V_{DD}$	–40	–100	–	μA
		$V_{DD} = 5\text{ V}; V_O = V_{SS}$	–	–140	–400	μA
I_{OH2}	HIGH level push-pull output source current	$V_{DD} = 5\text{ V}; V_O = V_{DD} - 0.4\text{ V}$	–3.0	–7.0	–	mA
TEST/EMU; RESET; INTN/T0; T1; HSYNEN; VSYNEN and T3						
V_{IL}	LOW level input voltage		0	–	$0.3V_{DD}$	V
V_{IH}	HIGH level input voltage		$0.7V_{DD}$	–	V_{DD}	V
I_{LI}	input leakage current	$V_{SS} < V_I < V_{DD}$	–1.0	–	+1.0	μA

Microcontroller for monitor OSD and auto-sync applications

PCE84C886

20 AC CHARACTERISTICS

SYMBOL	PARAMETER	CONDITIONS	MIN.	TYP.	MAX.	UNIT
f _{xtal}	Crystal oscillator frequency Option 1: g _m = 0.4 mS Option 2: g _m = 1.2 mS	V _{DD} = 5 V	1	–	6	MHz
			4	–	10	MHz
f _{PXE}	PXE resonator frequency Option 2: g _m = 1.2 mS	V _{DD} = 5 V	1	–	6	MHz
f _{OSD}	OSD clock frequency		4.0	–	14	MHz
f _{Hsync}	Hsync frequency	duty cycle = 10 : 90	30	–	64	kHz
f _{Vsync}	Vsync frequency	duty cycle = 10 : 90	50	–	120	Hz
C _{OSD}	external capacitance at pin C		–	0.33	–	μF
C _{xtal1}	external capacitance at XTAL1 (IN) pin (PXE resonator)		–	30	100	pF
C _{xtal2}	external capacitance at XTAL2 (OUT) pin (PXE resonator)		–	30	100	pF
t _{T3}	minimum pulse width period at T3 input	rising or falling edge of T3 pulse < 30 ns	1	–	–	μs
Analog-to-Digital (software) Converter						
V _{AI}	comparator analog input voltages ADC0; ADC1 and ADC2		V _{SS}	–	V _{DD}	V
V _{AE}	conversion error range		–	–	±1/2	LSB
T _{AFC}	conversion time (from any change in ADC input i.e. channel number; voltage level or enable/disable)		–	–	7	μs

**Microcontroller for monitor OSD
and auto-sync applications**

PCE84C886

21 DEVELOPMENT SUPPORT

Table 39 details the hardware items available for development support and Table 40 lists the development support documentation.

Table 39 Hardware

ITEM	TYPE	ORDER NUMBER
LCDS Development System		
Mother board - LCDS84	OM1025	9339 931 50112
Daughter board - LCD84C846	OM4833	9350 426 00112
Piggy-back version		
PCA84C841B	–	9350 419 50112

Table 40 Documentation

DOCUMENT NAME	REPORT NUMBER
OSD + BCM monitor application board (BCM9211) and software (Version 1.0)	Taiwan/AN9302
OSD + BCM Software Version 1.1 and Monitor Application Board (BCM9211)	Taiwan/AN9308
PCE84C886 OSD microcontroller optimization techniques	Taiwan/AN9311

Microcontroller for monitor OSD
and auto-sync applications

PCE84C886

22 PACKAGE OUTLINE

SDIP42: plastic shrink dual in-line package; 42 leads (600 mil)

SOT270-1

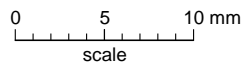
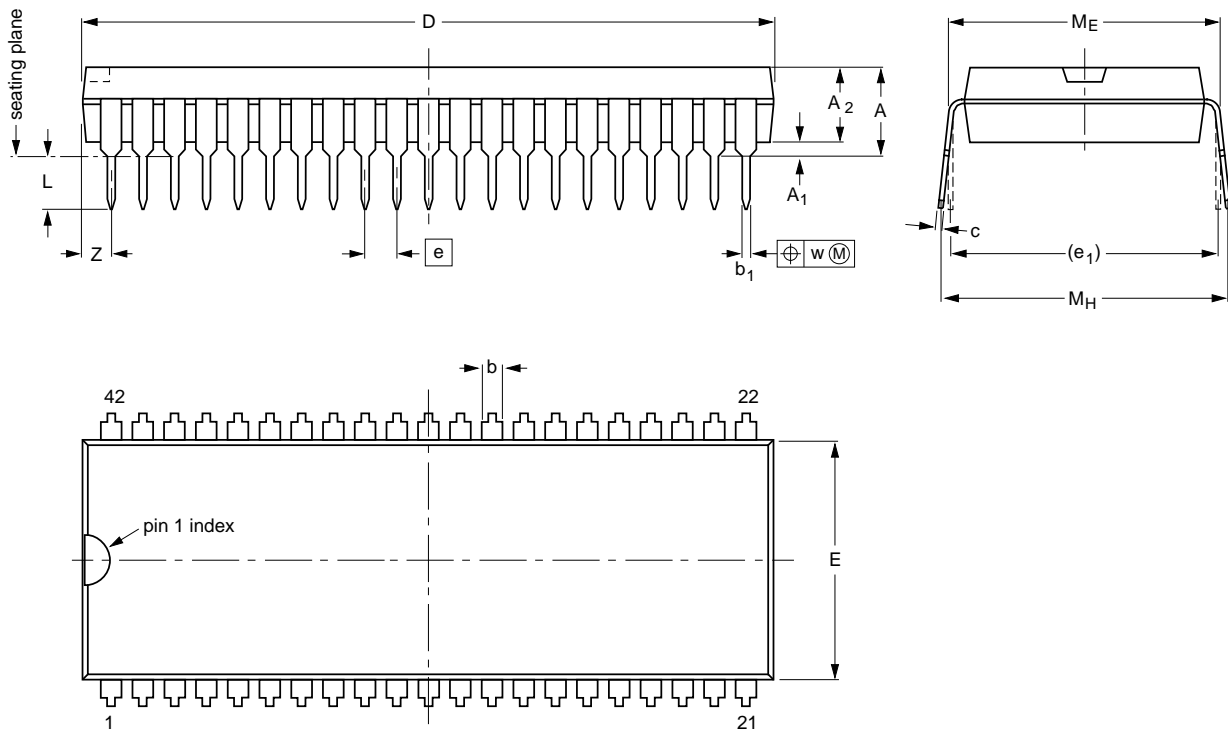

DIMENSIONS (mm are the original dimensions)

UNIT	A max.	A ₁ min.	A ₂ max.	b	b ₁	c	D ⁽¹⁾	E ⁽¹⁾	e	e ₁	L	M _E	M _H	w	Z ⁽¹⁾ max.
mm	5.08	0.51	4.0	1.3 0.8	0.53 0.40	0.32 0.23	38.9 38.4	14.0 13.7	1.778	15.24	3.2 2.9	15.80 15.24	17.15 15.90	0.18	1.73

Note

1. Plastic or metal protrusions of 0.25 mm maximum per side are not included.

OUTLINE VERSION	REFERENCES				EUROPEAN PROJECTION	ISSUE DATE
	IEC	JEDEC	EIAJ			
SOT270-1						90-02-13 95-02-04

Microcontroller for monitor OSD and auto-sync applications

PCE84C886

23 SOLDERING

23.1 Introduction

There is no soldering method that is ideal for all IC packages. Wave soldering is often preferred when through-hole and surface mounted components are mixed on one printed-circuit board. However, wave soldering is not always suitable for surface mounted ICs, or for printed-circuits with high population densities. In these situations reflow soldering is often used.

This text gives a very brief insight to a complex technology. A more in-depth account of soldering ICs can be found in our "*IC Package Databook*" (order code 9398 652 90011).

23.2 Soldering by dipping or by wave

The maximum permissible temperature of the solder is 260 °C; solder at this temperature must not be in contact with the joint for more than 5 seconds. The total contact time of successive solder waves must not exceed 5 seconds.

The device may be mounted up to the seating plane, but the temperature of the plastic body must not exceed the specified maximum storage temperature ($T_{stg\ max}$). If the printed-circuit board has been pre-heated, forced cooling may be necessary immediately after soldering to keep the temperature within the permissible limit.

23.3 Repairing soldered joints

Apply a low voltage soldering iron (less than 24 V) to the lead(s) of the package, below the seating plane or not more than 2 mm above it. If the temperature of the soldering iron bit is less than 300 °C it may remain in contact for up to 10 seconds. If the bit temperature is between 300 and 400 °C, contact may be up to 5 seconds.

Microcontroller for monitor OSD and auto-sync applications

PCE84C886

24 DEFINITIONS

Data sheet status	
Objective specification	This data sheet contains target or goal specifications for product development.
Preliminary specification	This data sheet contains preliminary data; supplementary data may be published later.
Product specification	This data sheet contains final product specifications.
Limiting values	
Limiting values given are in accordance with the Absolute Maximum Rating System (IEC 134). Stress above one or more of the limiting values may cause permanent damage to the device. These are stress ratings only and operation of the device at these or at any other conditions above those given in the Characteristics sections of the specification is not implied. Exposure to limiting values for extended periods may affect device reliability.	
Application information	
Where application information is given, it is advisory and does not form part of the specification.	

25 LIFE SUPPORT APPLICATIONS

These products are not designed for use in life support appliances, devices, or systems where malfunction of these products can reasonably be expected to result in personal injury. Philips customers using or selling these products for use in such applications do so at their own risk and agree to fully indemnify Philips for any damages resulting from such improper use or sale.

26 PURCHASE OF PHILIPS I²C COMPONENTS



Purchase of Philips I²C components conveys a license under the Philips' I²C patent to use the components in the I²C system provided the system conforms to the I²C specification defined by Philips. This specification can be ordered using the code 9398 393 40011.

Philips Semiconductors – a worldwide company

Argentina: IEROD, Av. Juramento 1992 - 14.b, (1428)
BUENOS AIRES, Tel. (541)786 7633, Fax. (541)786 9367

Australia: 34 Waterloo Road, NORTH RYDE, NSW 2113,
Tel. (02)805 4455, Fax. (02)805 4466

Austria: Triester Str. 64, A-1101 WIEN, P.O. Box 213,
Tel. (01)60 101-1236, Fax. (01)60 101-1211

Belgium: Postbus 90050, 5600 PB EINDHOVEN, The Netherlands,
Tel. (31)40-2783749, Fax. (31)40-2788399

Brazil: Rua do Rocio 220 - 5th floor, Suite 51,
CEP: 04552-903-SÃO PAULO-SP, Brazil,
P.O. Box 7383 (01064-970),
Tel. (011)821-2333, Fax. (011)829-1849

Canada: PHILIPS SEMICONDUCTORS/COMPONENTS:
Tel. (800) 234-7381, Fax. (708) 296-8556

Chile: Av. Santa Maria 0760, SANTIAGO,
Tel. (02)773 816, Fax. (02)777 6730

China/Hong Kong: 501 Hong Kong Industrial Technology Centre,
72 Tat Chee Avenue, Kowloon Tong, HONG KONG,
Tel. (852)2319 7888, Fax. (852)2319 7700

Colombia: IPRELENZO LTDA, Carrera 21 No. 56-17,
77621 BOGOTA, Tel. (571)249 7624/(571)217 4609,
Fax. (571)217 4549

Denmark: Prags Boulevard 80, PB 1919, DK-2300
COPENHAGEN S, Tel. (45)32 88 26 36, Fax. (45)31 57 19 49

Finland: Sinikalliontie 3, FIN-02630 ESPOO,
Tel. (358)0-615 800, Fax. (358)0-61580 920

France: 4 Rue du Port-aux-Vins, BP317,
92156 SURESNES Cedex,
Tel. (01)4099 6161, Fax. (01)4099 6427

Germany: P.O. Box 10 51 40, 20035 HAMBURG,
Tel. (040)23 53 60, Fax. (040)23 53 63 00

Greece: No. 15, 25th March Street, GR 17778 TAVROS,
Tel. (01)4894 339/4894 911, Fax. (01)4814 240

India: Philips INDIA Ltd, Shivsagar Estate, A Block,
Dr. Annie Besant Rd. Worli, Bombay 400 018
Tel. (022)4938 541, Fax. (022)4938 722

Indonesia: Philips House, Jalan H.R. Rasuna Said Kav. 3-4,
P.O. Box 4252, JAKARTA 12950,
Tel. (021)5201 122, Fax. (021)5205 189

Ireland: Newstead, Clonskeagh, DUBLIN 14,
Tel. (01)7640 000, Fax. (01)7640 200

Italy: PHILIPS SEMICONDUCTORS S.r.l.,
Piazza IV Novembre 3, 20124 MILANO,
Tel. (0039)2 6752 2531, Fax. (0039)2 6752 2557

Japan: Philips Bldg 13-37, Kohnan 2-chome, Minato-ku, TOKYO 108,
Tel. (03)3740 5130, Fax. (03)3740 5077

Korea: Philips House, 260-199 Itaewon-dong,
Yongsan-ku, SEOUL, Tel. (02)709-1412, Fax. (02)709-1415

Malaysia: No. 76 Jalan Universiti, 46200 PETALING JAYA,
SELANGOR, Tel. (03)750 5214, Fax. (03)757 4880

Mexico: 5900 Gateway East, Suite 200, EL PASO, TX 79905,
Tel. 9-5(800)234-7381, Fax. (708)296-8556

Netherlands: Postbus 90050, 5600 PB EINDHOVEN, Bldg. VB,
Tel. (040)2783749, Fax. (040)2788399

New Zealand: 2 Wagener Place, C.P.O. Box 1041, AUCKLAND,
Tel. (09)849-4160, Fax. (09)849-7811

Norway: Box 1, Manglerud 0612, OSLO,
Tel. (022)74 8000, Fax. (022)74 8341

Pakistan: Philips Electrical Industries of Pakistan Ltd.,
Exchange Bldg. ST-2/A, Block 9, KDA Scheme 5, Clifton,
KARACHI 75600, Tel. (021)587 4641-49,
Fax. (021)577035/5874546

Philippines: PHILIPS SEMICONDUCTORS PHILIPPINES Inc.,
106 Valero St. Salcedo Village, P.O. Box 2108 MCC, MAKATI,
Metro MANILA, Tel. (63) 2 816 6380, Fax. (63) 2 817 3474

Portugal: PHILIPS PORTUGUESA, S.A.,
Rua dr. António Loureiro Borges 5, Arquiparque - Miraflores,
Apartado 300, 2795 LINDA-A-VELHA,
Tel. (01)4163160/4163333, Fax. (01)4163174/4163366

Singapore: Lorong 1, Toa Payoh, SINGAPORE 1231,
Tel. (65)350 2000, Fax. (65)251 6500

South Africa: S.A. PHILIPS Pty Ltd.,
195-215 Main Road Martindale, 2092 JOHANNESBURG,
P.O. Box 7430, Johannesburg 2000,
Tel. (011)470-5911, Fax. (011)470-5494

Spain: Balmes 22, 08007 BARCELONA,
Tel. (03)301 6312, Fax. (03)301 42 43

Sweden: Kottbygatan 7, Akalla. S-164 85 STOCKHOLM,
Tel. (0)8-632 2000, Fax. (0)8-632 2745

Switzerland: Allmendstrasse 140, CH-8027 ZÜRICH,
Tel. (01)488 2211, Fax. (01)481 77 30

Taiwan: PHILIPS TAIWAN Ltd., 23-30F, 66, Chung Hsiao West
Road, Sec. 1. Taipeh, Taiwan ROC, P.O. Box 22978,
TAIPEI 100, Tel. (886) 2 382 4443, Fax. (886) 2 382 4444

Thailand: PHILIPS ELECTRONICS (THAILAND) Ltd.,
209/2 Sanpavuth-Bangna Road Prakanong,
Bangkok 10260, THAILAND,
Tel. (66) 2 745-4090, Fax. (66) 2 398-0793

Turkey: Talatpasa Cad. No. 5, 80640 GÜLTEPE/ISTANBUL,
Tel. (0212)279 27 70, Fax. (0212)282 67 07

Ukraine: Philips UKRAINE, 2A Akademika Koroleva str., Office 165,
252148 KIEV, Tel. 380-44-4760297, Fax. 380-44-4766991

United Kingdom: Philips Semiconductors LTD.,
276 Bath Road, Hayes, MIDDLESEX UB3 5BX,
Tel. (0181)730-5000, Fax. (0181)754-8421

United States: 811 East Arques Avenue, SUNNYVALE,
CA 94088-3409, Tel. (800)234-7381, Fax. (708)296-8556

Uruguay: Coronel Mora 433, MONTEVIDEO,
Tel. (02)70-4044, Fax. (02)92 0601

Internet: <http://www.semiconductors.philips.com/ps/>

For all other countries apply to: Philips Semiconductors,
International Marketing and Sales, Building BE-p,
P.O. Box 218, 5600 MD EINDHOVEN, The Netherlands,
Telex 35000 phtcnl, Fax. +31-40-2724825

SCDS47

© Philips Electronics N.V. 1996

All rights are reserved. Reproduction in whole or in part is prohibited without the prior written consent of the copyright owner.

The information presented in this document does not form part of any quotation or contract, is believed to be accurate and reliable and may be changed without notice. No liability will be accepted by the publisher for any consequence of its use. Publication thereof does not convey nor imply any license under patent- or other industrial or intellectual property rights.

Printed in The Netherlands

453061/1100/01/pp56
Document order number:

Date of release: 1996 Jan 08
9397 750 00551