

14 STAGE BINARY COUNTER/OSCILLATOR

- HIGH SPEED
 $f_{MAX} = 58 \text{ MHz (TYP.) AT } V_{CC} = 5 \text{ V}$
- LOW POWER DISSIPATION
 $I_{CC} = 4 \mu\text{A (MAX.) AT } T_A = 25 \text{ }^\circ\text{C}$
- HIGH NOISE IMMUNITY
 $V_{NIH} = V_{NIL} = 28 \% V_{CC} \text{ (MIN.)}$
- OUTPUT DRIVE CAPABILITY
 10 LSTTL LOADS
- SYMMETRICAL OUTPUT IMPEDANCE
 $|I_{OH}| = I_{OL} = 4 \text{ mA (MIN.)}$
- BALANCED PROPAGATION DELAYS
 $t_{PLH} = t_{PHL}$
- WIDE OPERATING VOLTAGE RANGE
 $V_{CC} \text{ (OPR)} = 2 \text{ V TO } 6 \text{ V}$
- PIN AND FUNCTION COMPATIBLE
 WITH 4060B

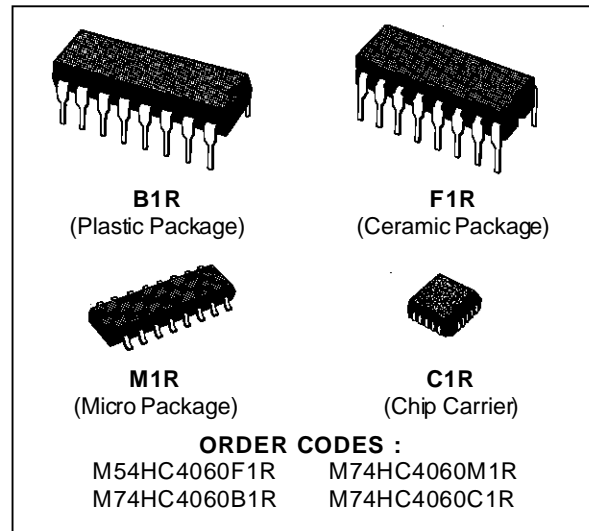

DESCRIPTION

The M54/74HC4060 is a high speed CMOS 14-STAGE BINARY COUNTER/OSCILLATOR fabricated in silicon gate C²MOS technology. It has the same high speed performance of LSTTL combined with true CMOS low power consumption. It operates ten times faster than metal-gate C²MOS IC (4060B) with the same power dissipation.

The oscillator configuration allows design of either RC or crystal oscillator circuits. A high level on the CLEAR accomplishes the reset function, i.e. all counter outputs are made low and the oscillator is disabled.

A negative transition on the clock input increments the counter. Ten kinds of divided output are provided ; 4 to 10 and 12 to 14 stage inclusive. The maximum division available at Q12 is 1/16384 f oscillator.

The $\overline{\phi}_1$ input and the CLEAR input are equipped with protection circuits against static discharge and transient excess voltage.

PIN CONNECTIONS (top view)

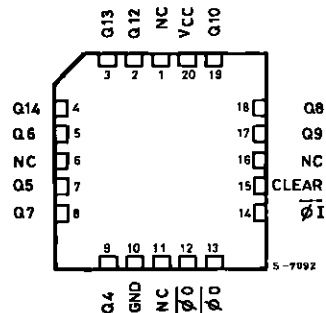
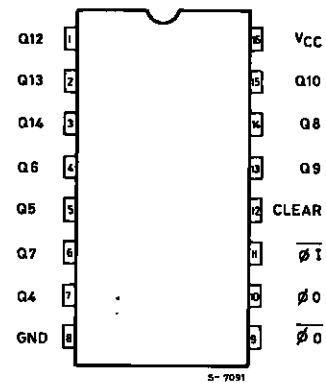

NC =
No Internal
Connection

M54/M74HC4060

INPUT AND OUTPUT EQUIVALENT CIRCUIT

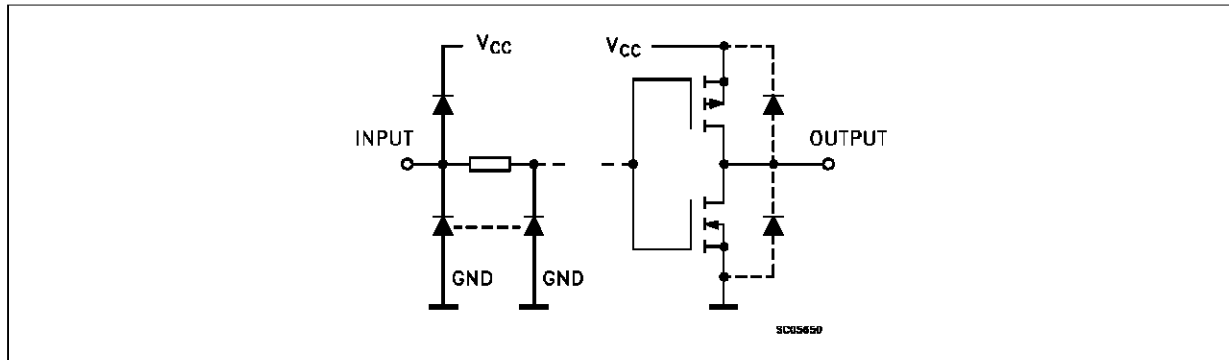

TRUTH TABLE

$\overline{\phi 1}$	CLEAR	FUNCTION
X	H	COUNTER IS RESET TO ZERO STATE $\phi 0$ OUTPUT GOES TO HIGH LEVEL $\overline{\phi 0}$ OUTPUT GOES TO LOW LEVEL
	L	COUNT UP ONE STEP
	L	NO CHANGE

X: DON'T CARE

LOGIC DIAGRAM

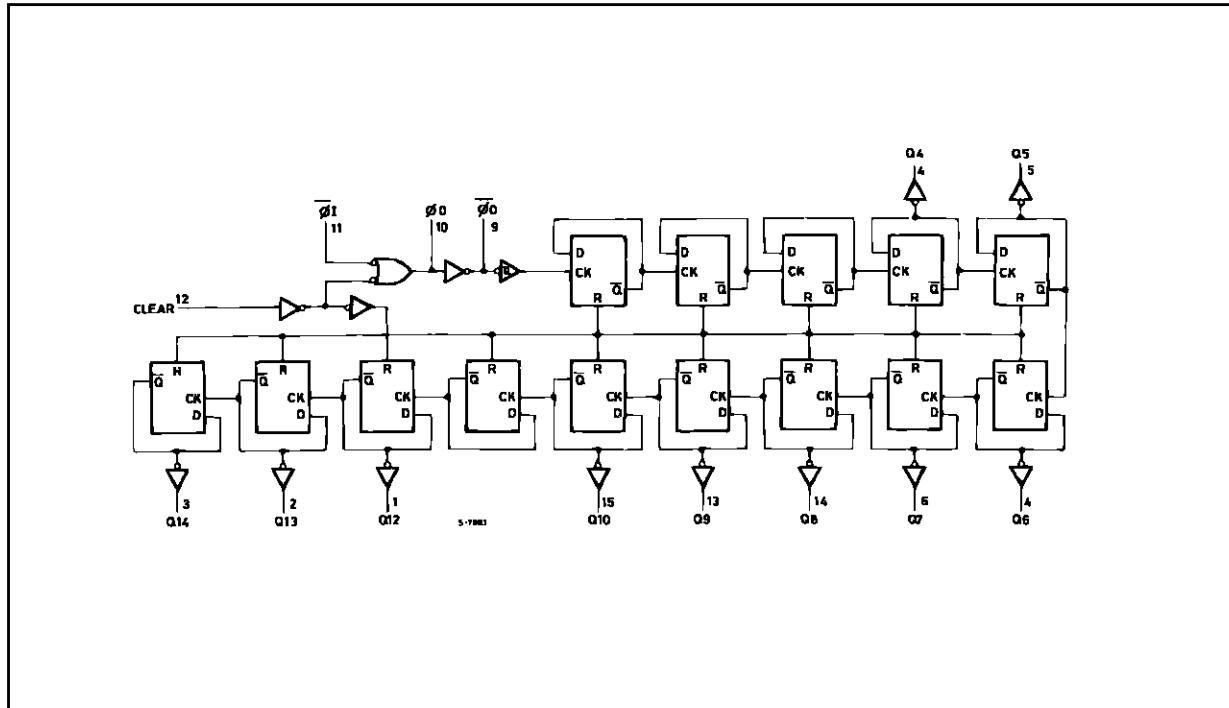

PIN DESCRIPTION

PIN No	SYMBOL	NAME AND FUNCTION
1, 2, 3	Q12 to Q14	Counter Outputs
7, 5, 4, 6, 14, 13, 15	Q4 to Q10	Counter Outputs
9	$\overline{\phi O}$	External Capacitor Connection
10	ϕO	External Resistor Connection
11	$\overline{\phi I}$	Clock Input/Oscillator Pin
12	CLEAR	Master Reset
8	GND	Ground (0V)
16	V _{CC}	Positive Supply Voltage

IEC LOGIC SYMBOL

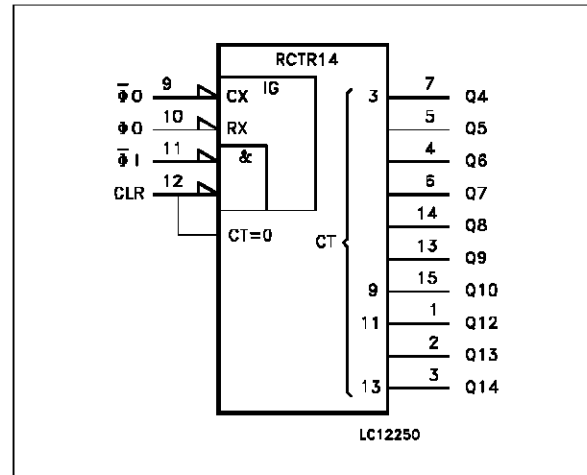

ABSOLUTE MAXIMUM RATINGS

Symbol	Parameter	Value	Unit
V _{CC}	Supply Voltage	-0.5 to +7	V
V _I	DC Input Voltage	-0.5 to V _{CC} + 0.5	V
V _O	DC Output Voltage	-0.5 to V _{CC} + 0.5	V
I _{IK}	DC Input Diode Current	± 20	mA
I _{OK}	DC Output Diode Current	± 20	mA
I _O	DC Output Source Sink Current Per Output Pin	± 25	mA
I _{CC} or I _{GND}	DC V _{CC} or Ground Current	± 50	mA
P _D	Power Dissipation	500 (*)	mW
T _{stg}	Storage Temperature	-65 to +150	°C
T _L	Lead Temperature (10 sec)	300	°C

Absolute Maximum Ratings are those values beyond which damage to the device may occur. Functional operation under these condition is not implied.
 (*) 500 mW: ≅ 65 °C derate to 300 mW by 10mW/°C: 65 °C to 85 °C

RECOMMENDED OPERATING CONDITIONS

Symbol	Parameter	Value	Unit	
V _{CC}	Supply Voltage	2 to 6	V	
V _I	Input Voltage	0 to V _{CC}	V	
V _O	Output Voltage	0 to V _{CC}	V	
T _{op}	Operating Temperature: M54HC Series M74HC Series	-55 to +125 -40 to +85	°C °C	
t _r , t _f	Input Rise and Fall Time	V _{CC} = 2 V V _{CC} = 4.5 V V _{CC} = 6 V	0 to 1000 0 to 500 0 to 400	ns

DC SPECIFICATIONS

Symbol	Parameter	Test Conditions		Value						Unit		
		V _{CC} (V)		T _A = 25 °C 54HC and 74HC			-40 to 85 °C 74HC		-55 to 125 °C 54HC			
				Min.	Typ.	Max.	Min.	Max.	Min.		Max.	
V _{IH}	High Level Input Voltage	2.0		1.5			1.5		1.5		V	
		4.5		3.15			3.15		3.15			
		6.0		4.2			4.2		4.2			
V _{IL}	Low Level Input Voltage	2.0				0.5		0.5		0.5	V	
		4.5				1.35		1.35		1.35		
		6.0				1.8		1.8		1.8		
V _{OH}	High Level Output Voltage (Q Outputs)	2.0	V _I = V _{IH} or V _{IL}	I _O = -20 μA	1.9	2.0		1.9		1.9	V	
		4.5			4.4	4.5		4.4		4.4		
		6.0			5.9	6.0		5.9		5.9		
		4.5	I _O = -4.0 mA	4.18	4.31		4.13		4.10			
		6.0		I _O = -5.2 mA	5.68	5.8		5.63		5.60		
V _{OL}	Low Level Output Voltage (Q Outputs)	2.0	V _I = V _{IH} or V _{IL}	I _O = 20 μA		0.0	0.1		0.1		0.1	V
		4.5				0.0	0.1		0.1		0.1	
		6.0				0.0	0.1		0.1		0.1	
		4.5	I _O = 4.0 mA		0.17	0.26		0.33		0.40		
		6.0		I _O = 5.2 mA		0.18	0.26		0.33		0.40	
V _{OH}	High Level Output Voltage (∅O, ∅O Output)	2.0	V _I = V _{IH} or V _{IL}	I _O = -20 μA	1.8	2.0		1.8		1.8	V	
		4.5			4.4	4.5		4.0		4.0		
		6.0			5.5	5.9		5.5		5.5		
V _{OL}	Low Level Output Voltage (∅O, ∅O Output)	2.0	V _I = V _{IH} or V _{IL}	I _O = 20 μA		0.0	0.2		0.2		0.2	V
		4.5				0.0	0.5		0.5		0.5	
		6.0				0.1	0.5		0.5		0.5	
I _I	Input Leakage Current	6.0	V _I = V _{CC} or GND				±0.1		±1		±1	μA
I _{CC}	Quiescent Supply Current	6.0	V _I = V _{CC} or GND				4		40		80	μA

AC ELECTRICAL CHARACTERISTICS ($C_L = 50$ pF, Input $t_r = t_f = 6$ ns)

Symbol	Parameter	Test Conditions		Value						Unit	
		V _{CC} (V)		T _A = 25 °C 54HC and 74HC			-40 to 85 °C 74HC		-55 to 125 °C 54HC		
				Min.	Typ.	Max.	Min.	Max.	Min.		Max.
t _{TLH} t _{THL}	Output Transition Time	2.0			30	75		95		110	ns
		4.5			8	15		19		22	
		6.0			7	13		16		19	
t _{PLH} t _{PHL}	Propagation Delay Time (ø1 - Q4)	2.0			170	300		375		450	ns
		4.5			41	60		75		90	
		6.0			30	51		64		76	
t _{PD}	Propagation Delay Time Difference (Qn- Qn+1)	2.0			32	75		95		110	ns
		4.5			7	15		19		22	
		6.0			5	13		16		19	
t _{PLH} t _{PHL}	Propagation Delay Time (CLEAR - Qn)	2.0			85	195		245		295	ns
		4.5			23	39		49		59	
		6.0			17	33		42		50	
f _{MAX}	Maximum Clock Frequency	2.0			6	12		5		4	ns
		4.5			30	50		24		20	
		6.0			35	65		28		24	
t _{W(H)} t _{W(L)}	Minimum Pulse Width (ø1)	2.0			30	75		95		110	ns
		4.5			8	15		19		22	
		6.0			7	13		16		19	
t _{W(H)}	Minimum Pulse Width (CLEAR)	2.0			30	75		95		110	ns
		4.5			8	15		19		22	
		6.0			7	13		16		19	
t _{REM}	Minimum Removal Time	2.0			40	100		125		150	ns
		4.5			10	20		25		30	
		6.0			9	17		21		26	
C _{IN}	Input Capacitance				5	10		10		10	pF
C _{PD} (*)	Power Dissipation Capacitance				27						pF

(*) C_{PD} is defined as the value of the IC's internal equivalent capacitance which is calculated from the operating current consumption without load. (Refer to Test Circuit). Average operating current can be obtained by the following equation. $I_{CC(opr)} = C_{PD} \cdot V_{CC} \cdot f_{IN} + I_{CC}$

SWITCHING CHARACTERISTICS TEST CIRCUIT

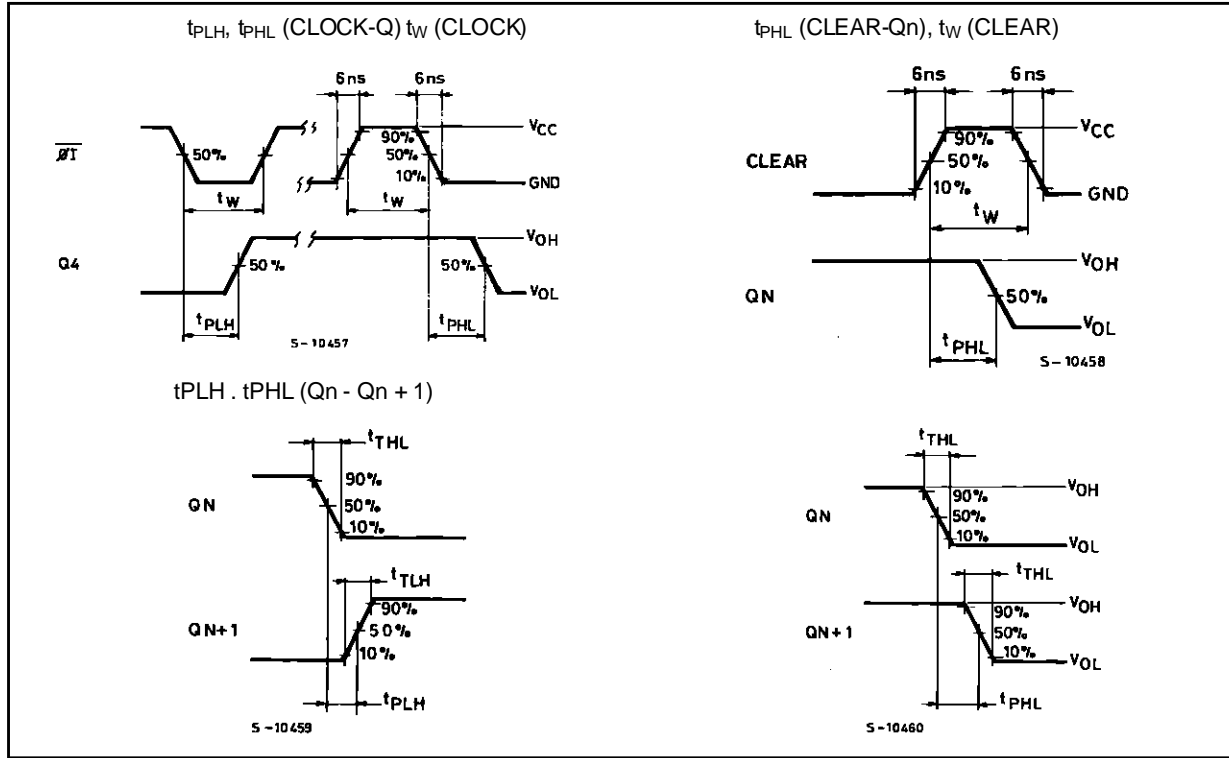

TEST CIRCUIT I_{CC} (Opr.)

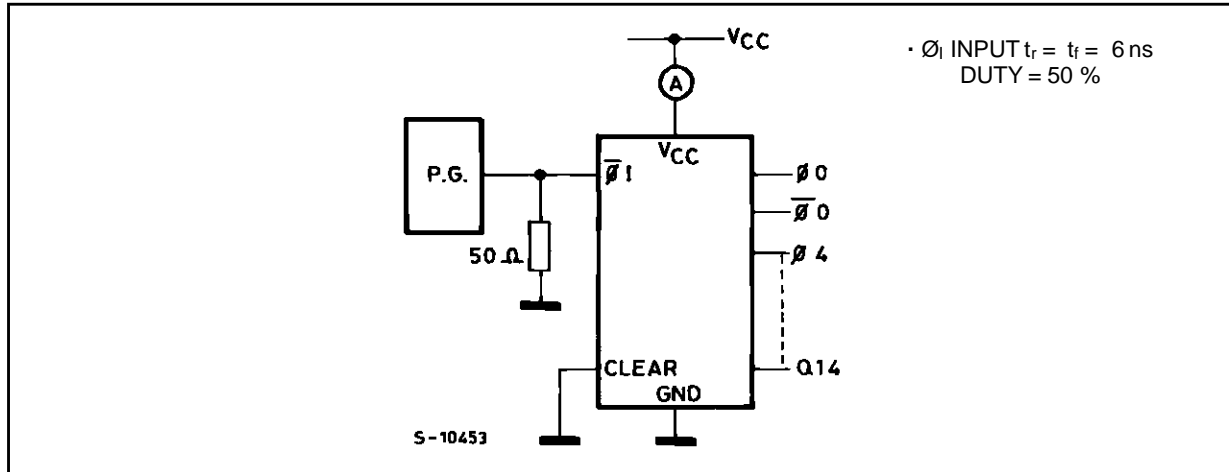

Note : When CR or crystal oscillation circuit is adopted, the dynamic power dissipation will be greater than the measured value from the test circuit shown left, because these oscillation circuits spend much supply current.

TYPICAL CLOCK DRIVE CIRCUITS

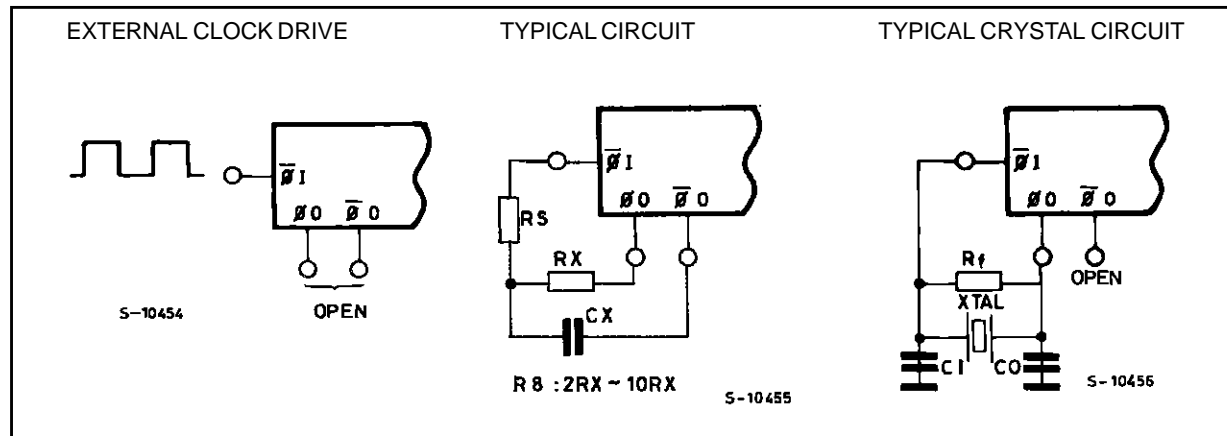

Plastic DIP16 (0.25) MECHANICAL DATA

DIM.	mm			inch		
	MIN.	TYP.	MAX.	MIN.	TYP.	MAX.
a1	0.51			0.020		
B	0.77		1.65	0.030		0.065
b		0.5			0.020	
b1		0.25			0.010	
D			20			0.787
E		8.5			0.335	
e		2.54			0.100	
e3		17.78			0.700	
F			7.1			0.280
I			5.1			0.201
L		3.3			0.130	
Z			1.27			0.050

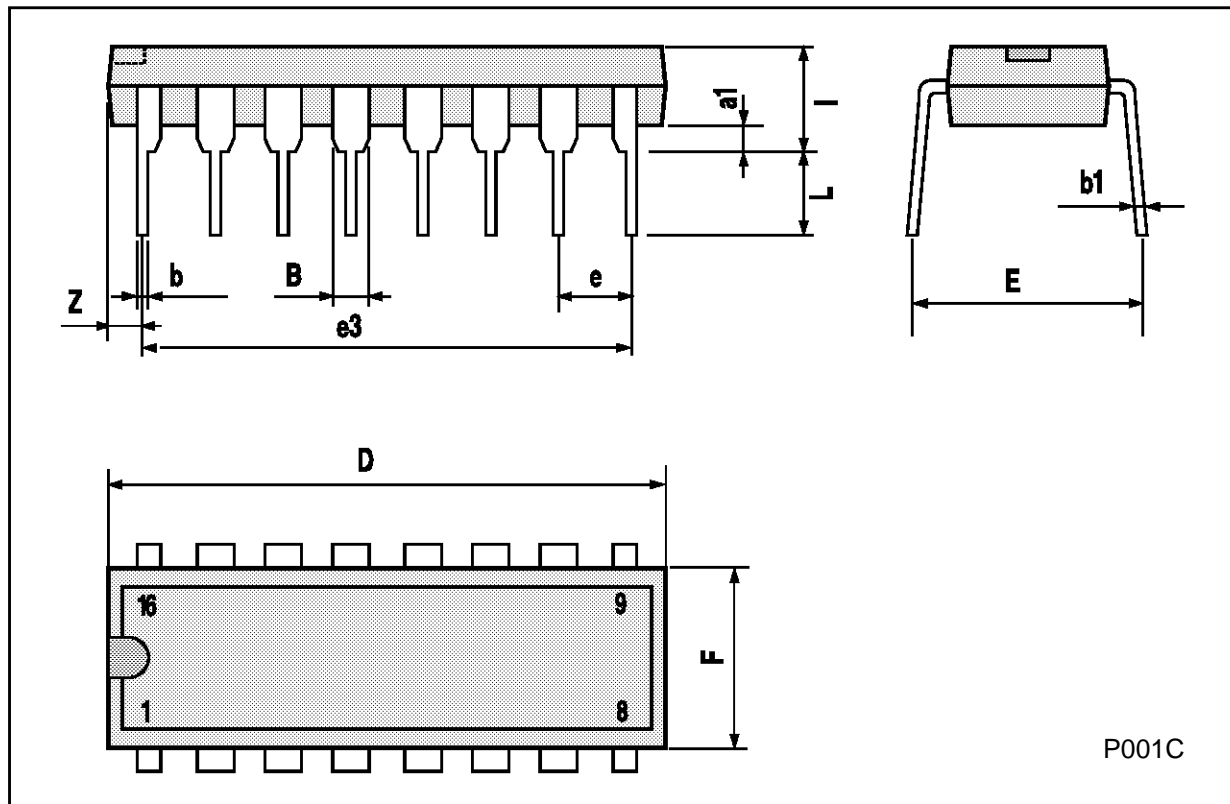

P001C

Ceramic DIP16/1 MECHANICAL DATA

DIM.	mm			inch		
	MIN.	TYP.	MAX.	MIN.	TYP.	MAX.
A			20			0.787
B			7			0.276
D		3.3			0.130	
E	0.38			0.015		
e3		17.78			0.700	
F	2.29		2.79	0.090		0.110
G	0.4		0.55	0.016		0.022
H	1.17		1.52	0.046		0.060
L	0.22		0.31	0.009		0.012
M	0.51		1.27	0.020		0.050
N			10.3			0.406
P	7.8		8.05	0.307		0.317
Q			5.08			0.200

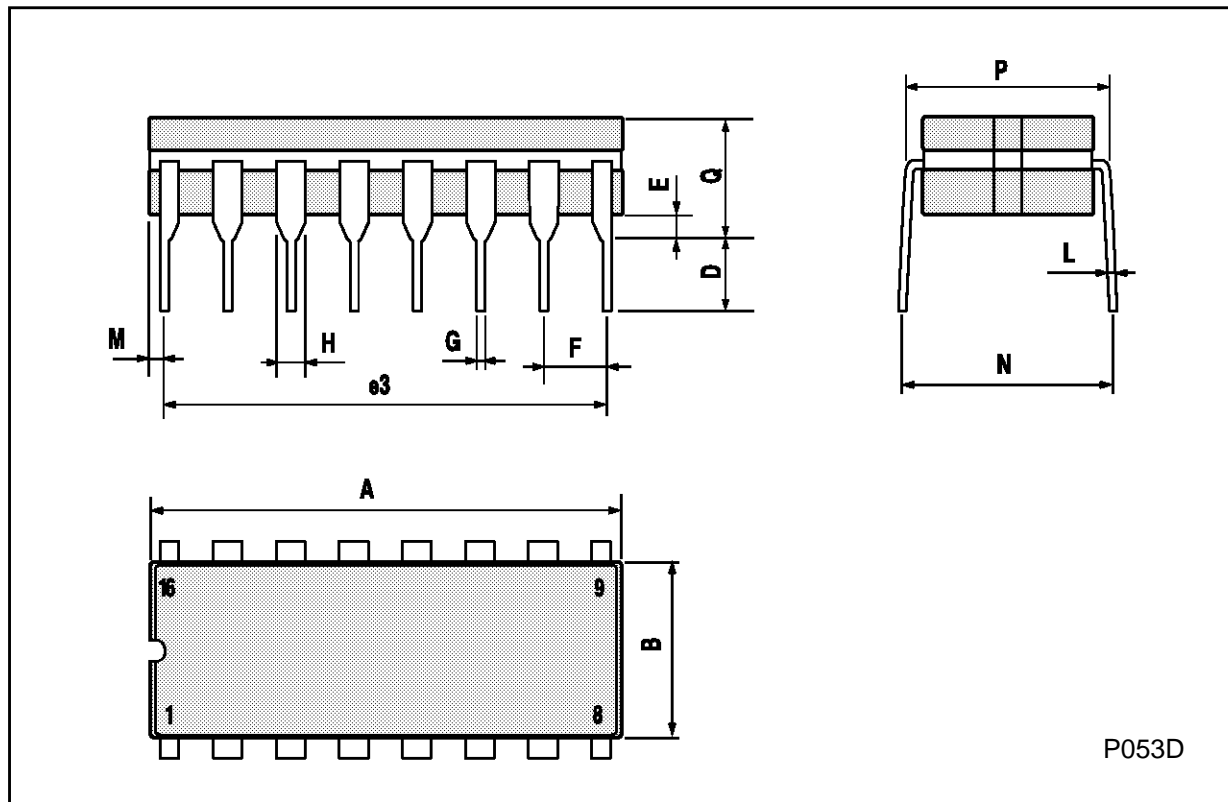

SO16 (Narrow) MECHANICAL DATA

DIM.	mm			inch		
	MIN.	TYP.	MAX.	MIN.	TYP.	MAX.
A			1.75			0.068
a1	0.1		0.2	0.004		0.007
a2			1.65			0.064
b	0.35		0.46	0.013		0.018
b1	0.19		0.25	0.007		0.010
C		0.5			0.019	
c1	45° (typ.)					
D	9.8		10	0.385		0.393
E	5.8		6.2	0.228		0.244
e		1.27			0.050	
e3		8.89			0.350	
F	3.8		4.0	0.149		0.157
G	4.6		5.3	0.181		0.208
L	0.5		1.27	0.019		0.050
M			0.62			0.024
S	8° (max.)					

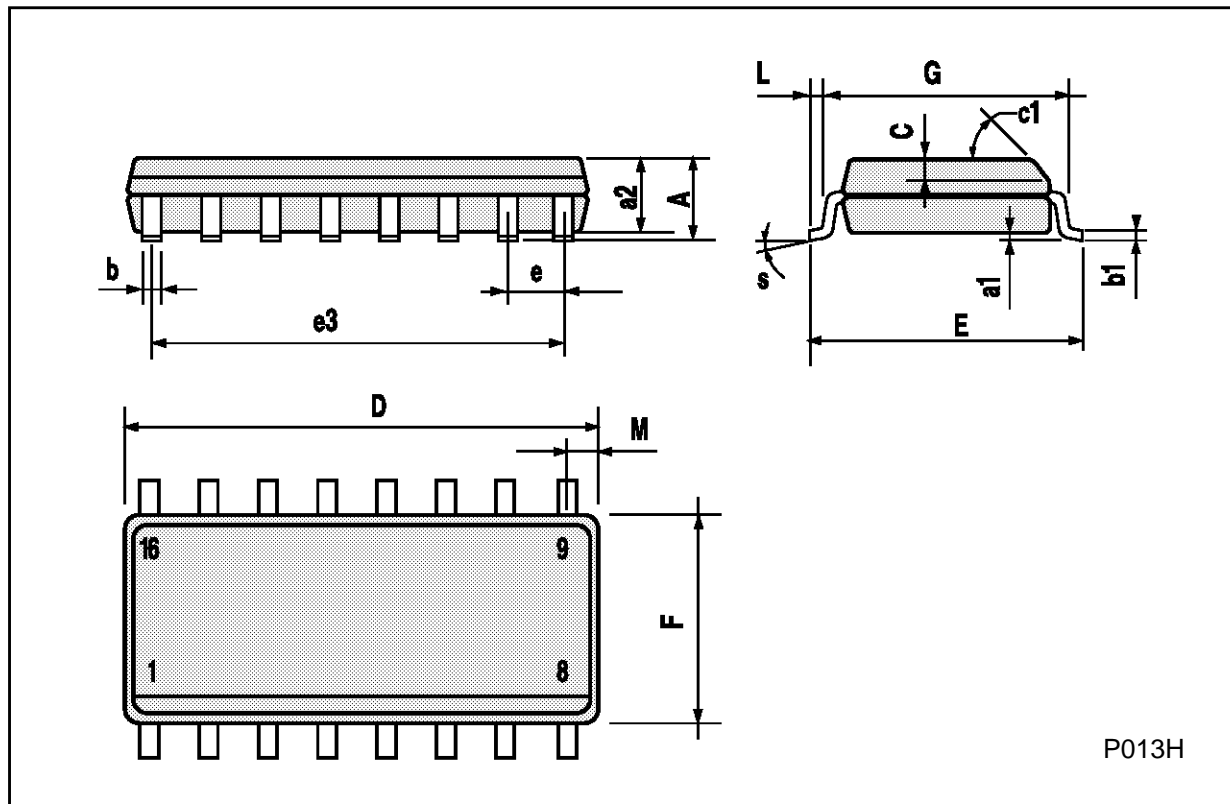

P013H

PLCC20 MECHANICAL DATA

DIM.	mm			inch		
	MIN.	TYP.	MAX.	MIN.	TYP.	MAX.
A	9.78		10.03	0.385		0.395
B	8.89		9.04	0.350		0.356
D	4.2		4.57	0.165		0.180
d1		2.54			0.100	
d2		0.56			0.022	
E	7.37		8.38	0.290		0.330
e		1.27			0.050	
e3		5.08			0.200	
F		0.38			0.015	
G			0.101			0.004
M		1.27			0.050	
M1		1.14			0.045	

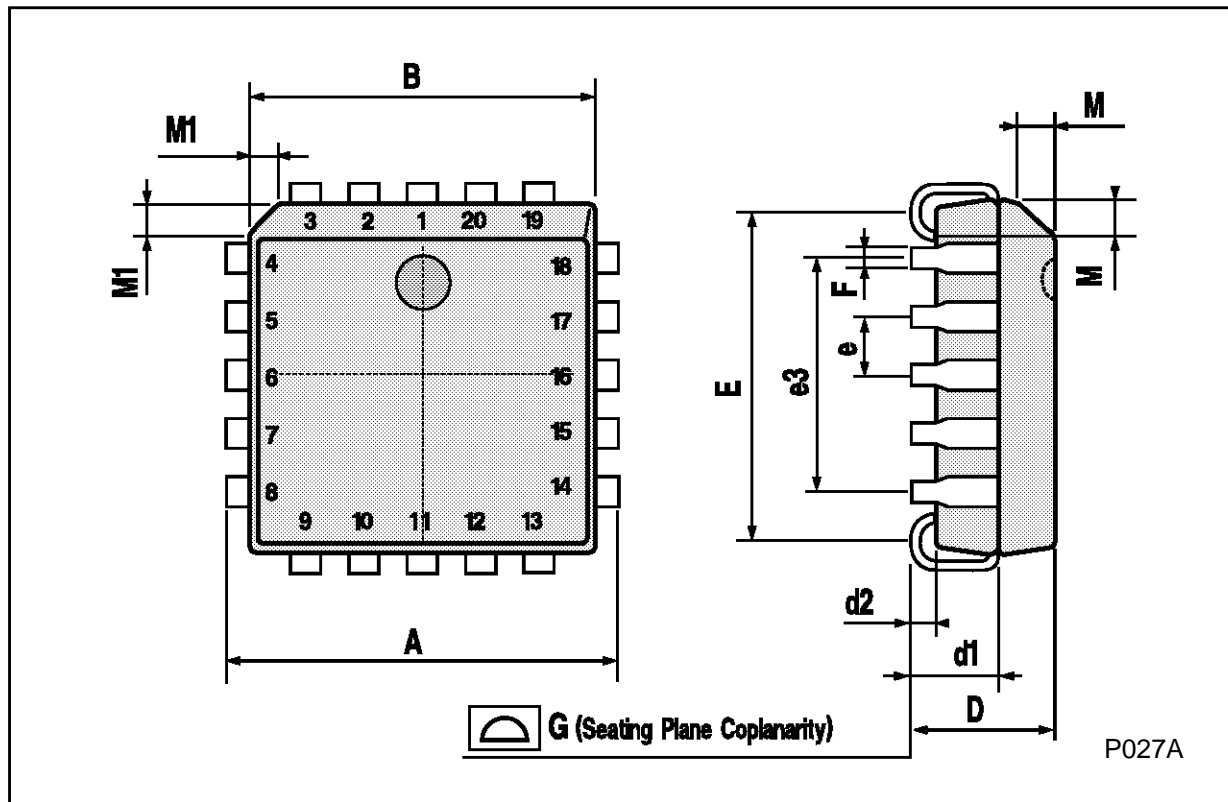

Information furnished is believed to be accurate and reliable. However, SGS-THOMSON Microelectronics assumes no responsibility for the consequences of use of such information nor for any infringement of patents or other rights of third parties which may result from its use. No license is granted by implication or otherwise under any patent or patent rights of SGS-THOMSON Microelectronics. Specifications mentioned in this publication are subject to change without notice. This publication supersedes and replaces all information previously supplied. SGS-THOMSON Microelectronics products are not authorized for use as critical components in life support devices or systems without express written approval of SGS-THOMSON Microelectronics.

© 1994 SGS-THOMSON Microelectronics - All Rights Reserved

SGS-THOMSON Microelectronics GROUP OF COMPANIES

Australia - Brazil - France - Germany - Hong Kong - Italy - Japan - Korea - Malaysia - Malta - Morocco - The Netherlands -
Singapore - Spain - Sweden - Switzerland - Taiwan - Thailand - United Kingdom - U.S.A