

DSP56166 DSP56166ROM

Product Brief

16-bit Digital Signal Processor

The DSP56166 is a general-purpose MPU-style Digital Signal Processor (DSP). On a single semiconductor chip, the DSP56166 comprises a very efficient 16-bit digital signal processing core, program and data memories, a number of peripherals, and system support circuitry. Like the DSP56156, the DSP56166 (see Figure 1) features a timer, two serial ports, a byte-wide host port, a built-in sigma-delta ($\Sigma\Delta$) codec, and a phase-locked loop (PLL). The DSP56166, with additional data memory and lower power consumption is a cost-effective, high-performance solution for many DSP applications, especially for speech coding and portable digital communications.

The central processing unit of the DSP56166 is the DSP56100 core processor. Like all DSP56100-based DSPs, the DSP56166 consists of three execution units operating in parallel, allowing up to six operations to be performed during each instruction cycle. This parallelism greatly increases the effective processing speed of the DSP56166. The MPU-style programming model and instruction set allow straightforward generation of efficient, compact code. The basic architectures and development tools of Motorola's 16-bit, 24-bit, and 32-bit DSPs are so similar that understanding how to design and program one greatly reduces the time needed to learn the others.

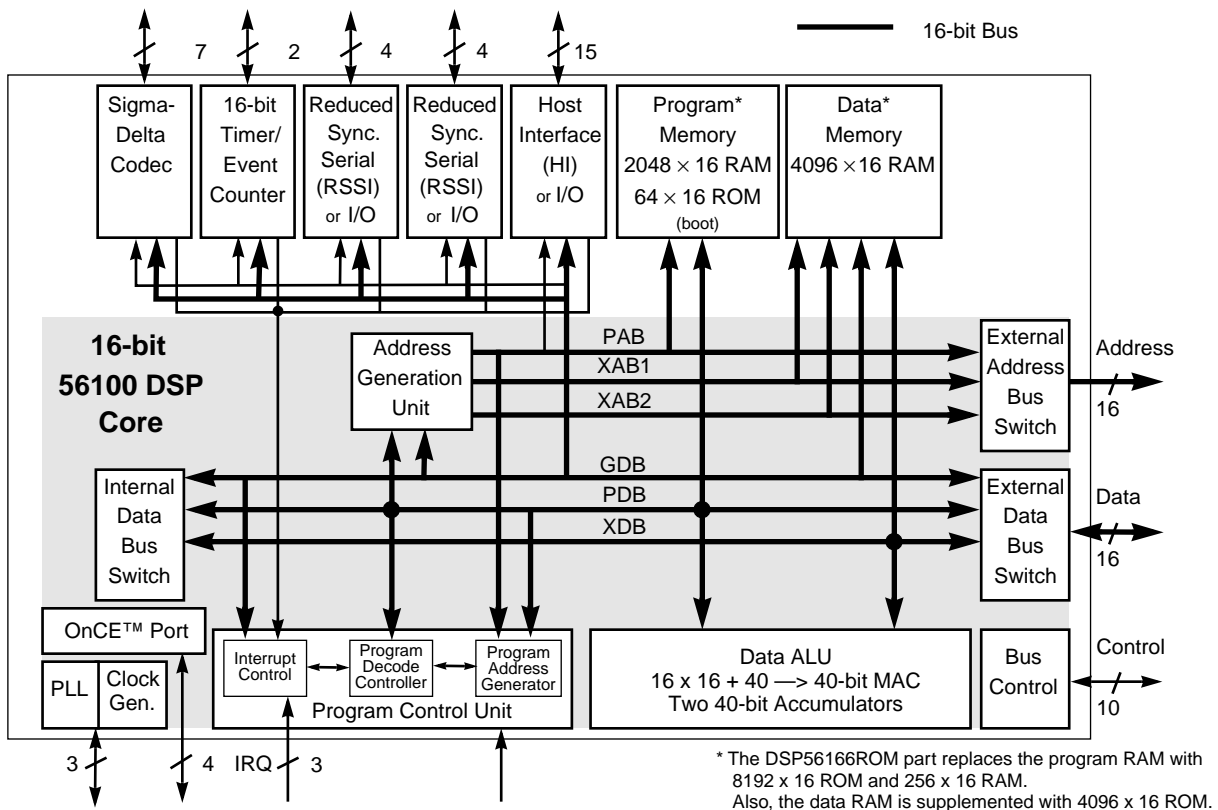

Figure 1 DSP56166 Block Diagram

Specifications and information herein are subject to change without notice.
OnCE is a trademark of Motorola, Inc.



DSP56166 Features

Digital Signal Processing Core

- Efficient, object code compatible, 16-bit 56100-Family DSP engine
 - Up to 30 Million Instructions Per Second (MIPS) – 33 ns instruction cycle at 60 MHz
 - Up to 180 Million Operations Per Second (MOPS) at 60 MHz
 - Highly parallel instruction set with unique DSP addressing modes
 - Two 40-bit accumulators including extension byte
 - Parallel 16×16 -bit multiply-accumulate in 1 instruction cycle (2 clock cycles)
 - Double precision 32×32 -bit multiply with 72-bit result in 6 instruction cycles
 - Least Mean Square (LMS) adaptive loop filter in 2 instructions
 - 40-bit Addition/Subtraction in 1 instruction cycle
 - Fractional and integer arithmetic with support for multiprecision arithmetic
 - Hardware support for block-floating point FFT
 - Hardware-nested DO loops including infinite loops
 - Zero-overhead fast interrupts (2 instruction cycles)
 - Three 16-bit internal data buses and three 16-bit internal address buses for maximum information transfer on-chip

Memory

- On-chip Harvard architecture permitting simultaneous accesses to program and memories
- 2048×16 -bit on-chip program RAM and 64×16 -bit bootstrap ROM (or 8192×16 -bit on-chip program ROM and 256×16 on-chip program RAM on the DSP56166ROM)
- 4096×16 -bit on-chip data RAM (and 4096×16 on-chip data ROM on the DSP56166ROM)
- External memory expansion with 16-bit address and data buses
- Bootstrap loading from external data bus, Host Interface (HI), or Reduced Synchronous Serial Interface (RSSI)

Peripheral and Support Circuits

- Byte-wide Host Interface (HI) with Direct Memory Access support
- Two Reduced Synchronous Serial Interfaces (RSSI) to communicate with codecs and synchronous serial devices
 - Up to 8 software-selectable time slots in network mode
- 16-bit Timer/Event Counter also generates and measures digital waveforms
- On-chip sigma-delta voice band Codec:
 - Sampling clock rates between 100 kHz and 3 MHz
 - Four software-programmable decimation/interpolation ratios
 - Internal voltage reference ($2/5$ of positive power supply)
 - No external components required

- On-chip peripheral registers memory mapped in data memory space
- Double buffered peripherals
- Up to 25 general purpose I/O pins
- Three external interrupt request pins
- On-Chip Emulation (OnCE™) port for unobtrusive, processor speed-independent debugging
- Software-programmable, Phase-Locked Loop based (PLL) frequency synthesizer for the core clock

Miscellaneous Features

- Power-saving Wait and Stop modes
- Fully static, HCMOS design for operating frequencies from 40 or 60 MHz down to DC
- 112-pin Ceramic Quad Flat Pack (CQFP) surface-mount package; 20 × 20 × 3 mm
- 112-pin Plastic Thin Quad Flat Pack (TQFP) surface-mount package; 20 × 20 × 1.4 mm
- 5 V power supply

Product Documentation

The data sheet plus the two manuals listed in Table 1 are required for a complete DSP56166 description and are necessary to properly design with the part. Documentation is available from a local Motorola distributor, a semiconductor sales office, or through a Motorola Literature Distribution Center.

Table 1 DSP56166 Documentation

Topic	Description	Order Number
DSP56100 Family Manual	Detailed description of the 56000-family architecture and the 16-bit core processor and instruction set	DSP56100FAMUM/AD
DSP56166 User's Manual	Detailed description of memory, peripherals, and interfaces	DSP56166UM/AD
DSP56166 Data Sheet	Pin and package descriptions, and electrical and timing specifications	DSP56166/D

Motorola reserves the right to make changes without further notice to any products herein. Motorola makes no warranty, representation or guarantee regarding the suitability of its products for any particular purpose, nor does Motorola assume any liability arising out of the application or use of any product or circuit, and specifically disclaims any and all liability, including without limitation consequential or incidental damages. "Typical" parameters can and do vary in different applications. All operating parameters, including "Typical", must be validated for each customer application by customer's technical experts. Motorola does not convey any license under its patent rights nor the rights of others. Motorola products are not designed, intended, or authorized for use as components in systems intended for surgical implant into the body, or other applications intended to support or sustain life, or for any other application in which the failure of the Motorola product could create a situation where personal injury or death may occur. Should Buyer purchase or use Motorola products for any such unintended or unauthorized application, Buyer shall indemnify and hold Motorola and its officers, employees, subsidiaries, affiliates, and distributors harmless against all claims, costs, damages, and expenses, and reasonable attorney fees arising out of, directly or indirectly, any claim of personal injury or death associated with such unintended or unauthorized use, even if such claim alleges that Motorola was negligent regarding the design or manufacture of the part.

Motorola and  are registered trademarks of Motorola, Inc.
Motorola, Inc. is an Equal Opportunity/Affirmative Action Employer.

Literature Distribution Centers:

USA: Motorola Literature Distribution; P.O. Box 20912; Phoenix, Arizona 85036.

EUROPE: Motorola Ltd.; European Literature Center; 88 Tanners Drive, Blakelands, Milton Keynes, MK14 5BP, Great Britain.

JAPAN: Nippon Motorola Ltd.; 4-32-1, Nishi-Gotanda, Shinagawa-ku, Tokyo 141 Japan.

ASIA-PACIFIC: Motorola Semiconductors H.K. Ltd.; Silicon Harbor Center, No. 2 Dai King Street, Tai Po Industrial Estate, Tai Po, N.T., Hong Kong.



MOTOROLA