

TEAC®

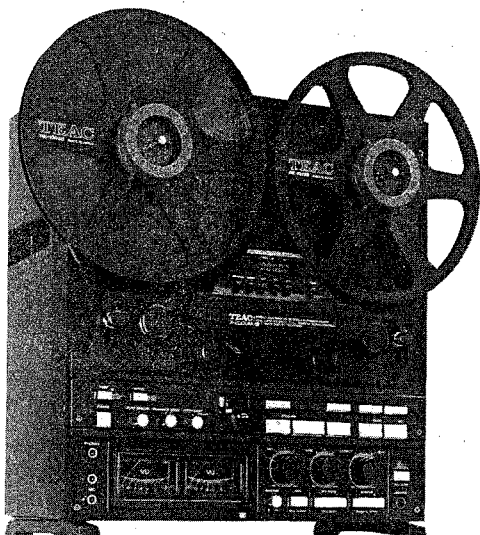

SERVICE MANUAL

X-2000M/X-2000

Stereo Tape Deck

- dbx Noise Reduction system made under license from dbx, Incorporated. The name "dbx" and the dbx symbol are trademarks of dbx, Incorporated.

CAUTION

△ Parts marked with this sign are safety critical components. They must always be replaced with identical components—refer to the appropriate parts list and ensure exact replacement.

- dbxおよびdbxマークはdbxインコーポレーテッドの登録商標です。
- dbxシステムはdbxインコーポレーテッドの実施権に基づいて製造されています。

注意

△印は安全重要部品です。交換する時は必ずティアック指定の部品を使用してください。

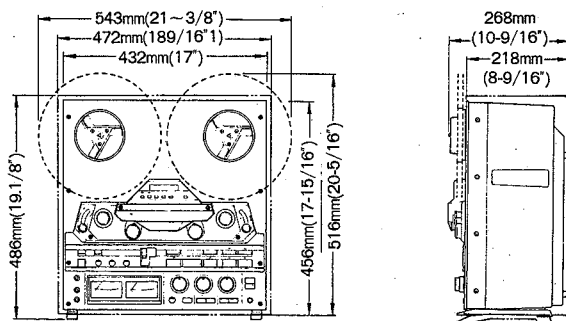

Fig. 1-1 Dimensions

1 SPECIFICATIONS AND SERVICE DATA

仕様とサービス・データ

SPECIFICATIONS

Track System

X-2000M: 2 track, 2 channel stereo or mono
4 track playback switchable

X-2000: 4 track, 2 channel stereo or mono

Head System

X-2000M: 4 heads: erase, record, 2T playback and 4T playback

X-2000: 3 heads: erase, record, playback

Reel Size 10-1/2" and 7"

Tape Speed

X-2000M: 38cm/s (15 ips) and 19cm/s (7-1/2 ips)

X-2000: 19cm/s (7-1/2 ips) and 9.5cm/s (3-3/4 ips)

Inputs (level and impedance)

MIC: Specified input level: -60dB (0.775mV)/10kohms
Min. input level: -70dB (245μV)

LINE IN: Specified input level: -12dB (195mV)/50kohms
Min. input level: -22dB (61.5mV)

Outputs (level and impedance)

OUTPUT: Specified output level: -5dB (436mV)/10kohms
Max. output level: +1dB (0.869V)

PHONES: Specified output level: -24dB (48.9mV)/8ohms

Playback equalization

	"LH" tape	"EE" tape
38cm/s:	3,180μs + 50μs ∞ + 35μs (IEC)	3,180μs + 35μs
19cm/s:	3,180μs + 50μs	3,180μs + 35μs
9.5cm/s:	3,180μs + 90μs	3,180μs + 50μs

Motors

Capstan motor: FG servo DC motor

Reel motor: 2 DC slotless motors

Bias Frequency 150kHz

Power Requirements X-2000M/X-2000

100/120/220/240V, AC 50/60Hz, 115W/110W (General export model)

220V AC 50Hz, 115W/110W (Europe model)

240V AC 50Hz, 115W/110W (U.K./Australia model)

120V AC 60Hz, 115W/110W (U.S.A./Canada model)

100V AC 50/60Hz, 80W/ — (Japan model)

Weight 21.0kg (46-5/16 lbs) net

25kg (55-1/8 lbs) (with wooden case)

Dimensions See page 1.

SERVICE DATA

MECHANICAL

Tape Speed Deviation 3,000Hz ± 30Hz

Tape Speed Drift 15Hz

Wow and Flutter

Playback: 38cm/s: 0.04% (WRMS), 0.08% (RMS)
19cm/s: 0.05% (WRMS), 0.10% (RMS)
9.5cm/s: 0.07% (WRMS), 0.12% (RMS)

Record/Playback: 38cm/s: 0.10% (RMS)

19cm/s: 0.12% (RMS)

9.5cm/s: 0.15% (RMS)

Pinch Roller Pressure 1.35kg ~ 1.9kg (3.0 lbs ~ 4.2 lbs)

Tape Tension

Play mode:

Take-up: 50g ± 10g (1.4oz ~ 2.1oz)

Supply: 50g ± 10g (1.4oz ~ 2.1oz)

Fast winding mode

Take-up: 110g ± 10g (3.5oz ~ 4.2oz)

Brake Torque

Forward direction: 1.2 ~ 1.9kg-cm (17 ~ 26oz-inch)

Reverse direction: 0.7kg-cm (9.7oz-inch) or less

Fast Winding Time 100 seconds or less for 550m (1800 feet)

Pitch Control Standard tape speed ±6% or more

TIMER Activate Time 4 sec. ± 2 sec.

ELECTRICAL

Frequency Response

Refer to the specifications in "3 ELECTRICAL ADJUSTMENTS AND CHECKS".

Signal to Noise Ratio (min. ratio)

	X-2000M		X-2000	
	LH	EE	LH	EE
Playback:				
38cm/s:	53dB	56dB	—	—
19cm/s:	53dB	56dB	49dB	53dB
9.5cm/s:	—	—	46dB	50dB
Overall:				
38cm/s:	52dB	55dB	—	—
19cm/s:	52dB	55dB	48dB	52dB
9.5cm/s:	—	—	45dB	49dB

Overall (dbx): 65dB min. (All speeds, various EQ tapes)

Erase Efficiency At 1kHz (measured with input 10dB higher than the specified input level)
68dB min.

Channel Separation 50dB min. at 1kHz

Adjacent Track Crosstalk 40dB min. at 125Hz (X-2000)

Total Harmonic Distortion At 1kHz, and at HIGH speed

0.8% or less (LH, EE)

0.8% or less (dbx IN)

- Improvements may result in SPECIFICATIONS AND SERVICE DATA changes.
- Value of "dB" in the data refers to 0dB (0.775V), except where specified.

注.

1. 仕様およびサービス・データは改善のため、予告なく変更することがあります。
2. 本マニュアルの0dBは0.775Vを基準としています。



2 MECHANICAL ADJUSTMENTS AND CHECKS

機構部の調整と確認

2-1 ROTATING PART THRUST CLEARANCE CHECKS

Reference values

Capstan shaft:	0.1mm to 0.25mm (magnefloat type)
Inertia roller:	0.05mm to 0.3mm
Tension arm guide roller:	0.05mm to 0.3mm
Reel motor:	0 (spring type)
Tension arm:	0 (spring type)

NOTE: Since the capstan shaft is a magnefloat type, check that it is forced towards the rear of the deck while rotating.

2-2 CAPSTAN MOTOR REPLACEMENT

1. When the capstan motor is replaced, install it with its lead wires and washers as shown.
2. Check that, when the deck is operated by repeating the forward and reverse play modes, the capstan drive belt changes position on the flywheels smoothly.

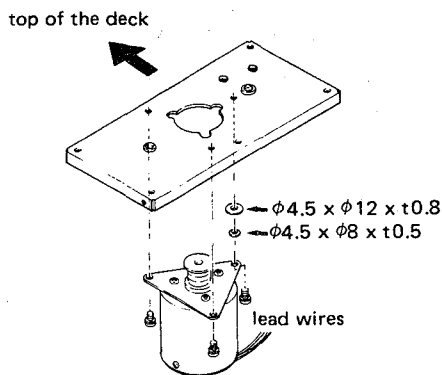

Fig. 2-1 Capstan motor replacement

2-3 BRAKE ADJUSTMENT

NOTE: The explanation and figure in this paragraph are for the left side brake, similar checks and adjustment are applicable for the right side one.

1. With brake applied (brake solenoid off), move brake band bracket in directions (A) so that brake arm comes in parallel with reel motor chassis.
2. Adjust the mounting position of brake solenoid in directions (D) so that when brake solenoid switches on and off the stroke of the solenoid plunger is about 2mm.
3. Adjust band ass'y retaining plate in directions (B), (C) and (E) so that brake felt does not touch brake drum when brake solenoid switches off.
4. Upon completion of adjustments, check that tape tension does not drop in any tape transport modes and there is not any tape winding troubles.

2-1 回転部のスラスト・クリアランス・チェック

以下は参考値(無調整)

キャプスタン・シャフト:	0.1~0.25mm(マグネフロート・タイプ)
ガイド・ローラ	: 0.05~0.3mm
テンション・アーム・ガイド・ローラ:	0.05~0.3mm
リール・モータ	: 0(スプリング・タイプ)
テンション・アーム	: 0(スプリング・タイプ)

注. キャプスタン・シャフトはマグネフロートタイプの為、定常回転中はスラスト受け方向(デッキ後面方向)に押されている事を確認すること。

2-2 キャプスタン・モータの交換

1. キャプスタン・モータを交換する場合は、図2-1の矢印が示すワッシャの取付け位置に注意すること。
2. 取付後FWD, REVを繰返したとき、キャプスタン・ベルトの走行位置がスムーズに切換ることを確認すること。

2-3 ブレーキ調整

1. ブレーキがかかった状態(ブレーキ・ソレノイドOFF)で、ブレーキ・アームとリール・モータ・シャーシのスキマが平行になるようブレーキ・バンド・ブラケット取付位置をA方向に調整する。
2. 次に、ブレーキ・ソレノイドをON・OFFしたときのプランジャのストロークが約2mmになるように、ブレーキ・ソレノイドの取付け位置をD方向に調整する。
3. ブレーキ・ソレノイドON状態の時、ブレーキ・ドラムとブレーキ・フェルトとが接触しないように、ブレーキ・バンド受けの取付け位置をB, C, E方向に調整する。
4. 調整後、すべてのテープ操作に於て、テンション落ち、テープ巻き込み等が生じないことを確認する。

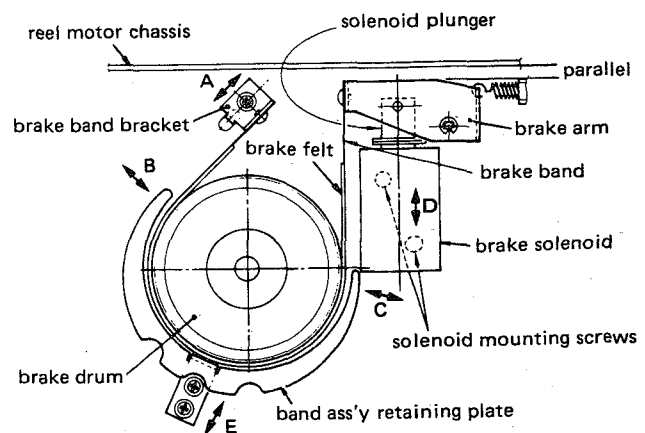

Fig. 2-2 Brake adjustment

2-4 BRAKE TORQUE MEASUREMENT

1. Place an empty 7" reel, connected to a spring scale by a string, on the reel table.
2. Pull the scale away from the reel and read the scale indication only when the reel table is steady motion.
3. Do steps 1 and 2 for each measuring condition, (A) through (D) in Fig. 2-3.
4. The values are as chart in Fig. 2-3.

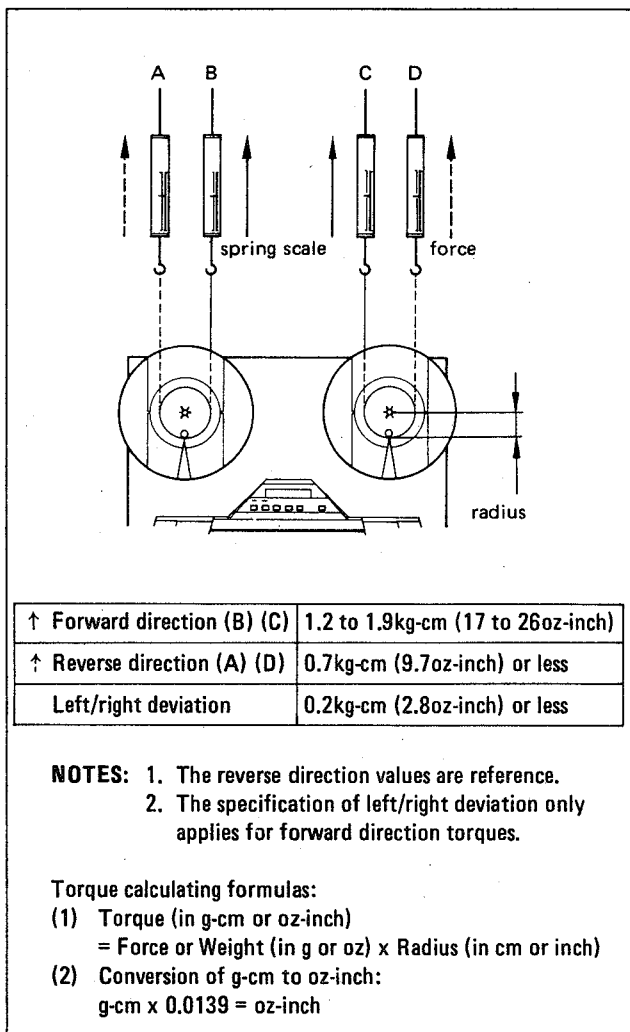

Fig. 2-3

2-5 PAUSE POSITION ADJUSTMENT

1. Place the deck in the pause mode.
2. Adjust by turning the pause positioning nut so that the clearance between the capstan shaft and the tape is 0.5mm to 1.0mm.
3. Of the two capstan shaft/pinch rollers, adjustment is allowable only for the side having the narrower clearance.
4. Check that, by repetition of play mode to pause mode and stop mode to pause mode, there is clearance at both sides.

2-4 ブレーキ・トルク測定

	正方向	負方向	左右差
右リール	1.2~1.9	0.7	0.2以下
左リール	1.2~1.9	0.7	

単位：kg・cm（トルクは参考値）

2-5 ピンチ・ローラ・ポーズ位置調整

デッキをポーズ状態にし、ポーズ位置調整ナットにより、キャプスタンとピンチローラ間のすき間を0.5~1.0mmに調整する。キャプスタンとピンチローラのすき間は、左右で差を生ずるが、調整はすき間の少ない側のみ行なう。調整後PLAY→PAUSE, STOP→PAUSEを何回か行ない、すき間を確認すること。

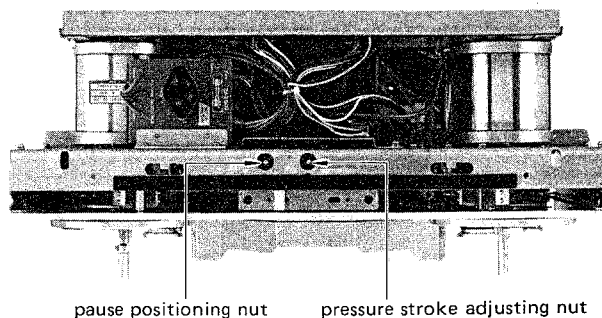

Fig. 2-4 Pause position and pinch roller pressure stroke adjustments

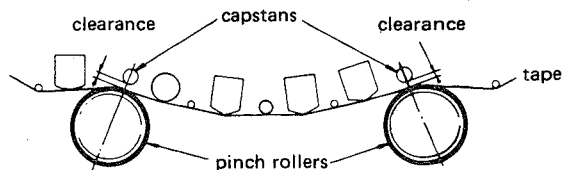
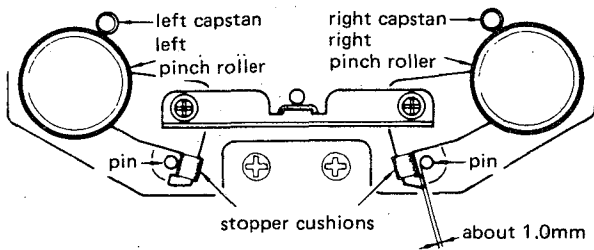

Fig. 2-5 Pause position adjustment

2-6 PINCH ROLLER PRESSURE STROKE ADJUSTMENT

1. Set the deck in the forward or reverse play mode.
2. Adjust by turning the pressure stroke adj. nut (Fig. 2-4) so that the clearance between the pin and the stopper cushion is about 1.0mm.
3. Since the clearance is produced at one side (left or right), adjustment for this side only is permissible.



Either the left or right should have a clearance of about 1.0mm.
スキマ1mm程度 (左右どちらか)

Fig. 2-6

2-7 PINCH ROLLER PRESSURE MEASUREMENT

- NOTES:**
1. The explanation below applies to both the left and right pinch rollers.
 2. Both pinch roller pressures are automatically set with equal value.

1. Hold both the left and right tension arms in the upper positions using rubber bands, string etc.
2. Set the deck in either play mode with no tape loaded.
3. Attach the spring scale to the pinch roller as shown in the figure.
4. Draw the pinch roller away from the capstan shaft (in the direction of a line intersecting the centers of the capstan shaft and the pinch roller) until the capstan shaft and the pinch roller are separated.
5. Return the scale back until the pinch roller just begins to turn. The scale should then be reading as follow.
Reference value: 1.35kg to 1.9kg (3.0 lbs to 4.2 lbs)
6. If the reading is out of specification, replace defective part(s).
There are no adjustable parts.

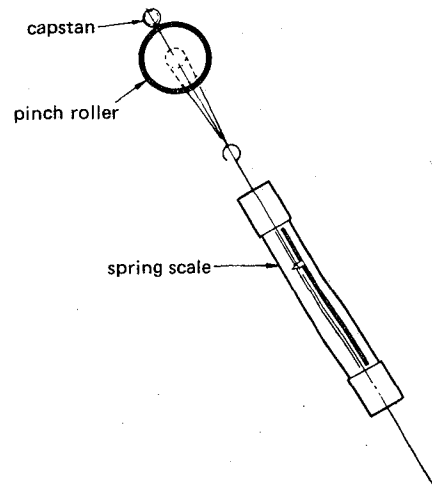

Fig. 2-7

2-6 ピンチローラ圧着ストローク調整

1. 調整時のデッキの作動モード……………PLAY
2. 図2-4に示す圧着ストローク調整ナットにより、図2-6に示すようにピンとストッパー・クッションのすき間を約1mmに調整する(ピンとストッパー・クッションが離れていて、すき間が確認出来れば良い)。
3. このすき間は、圧着スプリングのバラツキにより、左右いずれか一方にしか出来ないが、すき間の出来た側のみ調整すれば良い。

2-7 ピンチローラ圧着力測定

圧着力：1.35～1.9kg (戻し法)

注. 左右ピンチローラ圧着力は自動的にセットされ、また無調整方式なので上記規格を満足しない場合は部品交換が必要です。

2-8 TAPE TENSION ADJUSTMENT

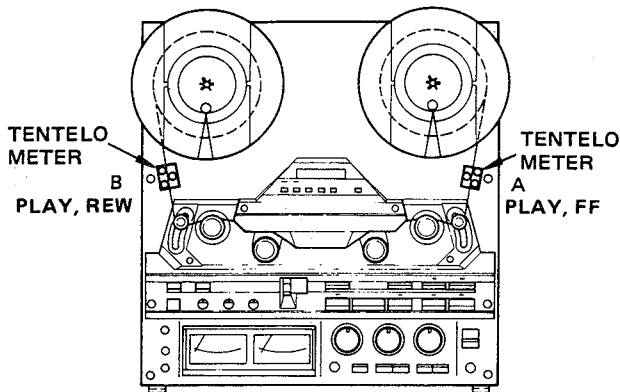

Fig. 2-8 Tape tension measuring points

NOTES

1. Since these settings are precisely factory adjusted, in general, they should not be re-adjusted. If it is specifically required, a special meter is needed.
Tentelo meter: Model T2-H20-1 or T2-H15-UM.
2. To facilitate adjustment, the deck should be placed in a vertical position.
3. For the reels mounted on both left and right reel tables, use the same size ones.
4. Before all the following adjustments (2-8-1 ~ 2-8-4), perform next instructions in order to activate the relevant circuit.
 - a. Thread the tape to lift up both tension/shut-off arms.
 - b. Set the POWER switch to ON.
 - c. Leave the deck as it is for 5 to 10 minutes.

2-8-1 IN PLAY MODE

1. Place a reel loading TEAC YTT-8013 test tape on the left reel table and an empty reel on the right reel table, then thread the tape.
2. Let the tape run in fast forward mode until both reels have nearly the same tape winding diameter.
3. During play with a LOW speed, measure tape tension at points A and B.
4. Adjust R122 and R222 so that the specified tape tension of $50g \pm 10g$ (1.4oz ~ 2.1 oz) is obtained.
(Obtain a 50g or 1.8oz value as far as possible).

2-8 テープ・テンション調整

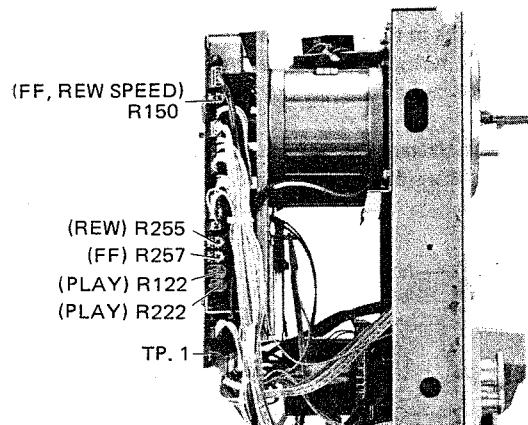

Fig. 2-9 Tape tension adjuster location

注意

1. テープ・テンションの測定には次のテンション・メータが必要です。
テンテロ・メータ (米国, テンテル社製)
モデル T2-H20-1又はT2-H15-UM
2. 測定及び調整は、デッキを垂直位置に行なってください。
3. 左右同サイズのリールを使用してください。
4. デッキの電源オン後5~10分以上経過してから測定・調整を行なってください。

2-8-1 PLAYテンション調整

1. テープ(7号リール, 10号リールどちらでもよい)をかけ, 左右同程度の巻径にする。
2. テープをLOW SPEED, PLAYモードで走行させる。
3. AおよびBの位置にテンテロ・メータを当て, R122, R222をまわしてテンションを $50g \pm 10g$ (できるだけ50gに近い値)に調整する。

2-8-3 IN FAST FORWARD MODE

1. Load a TEAC YTT-8013 test tape on the left reel table and an empty reel on the right reel table, then thread the tape.
2. Stop the left reel by hand and set the deck in fast forward mode.
3. Adjust R257 to obtain a 100g to 120g (3.5oz ~ 4.2oz) value at point A (Obtain a 110g or 3.9 oz value as far as possible).

REMARK: Back tension in fast forward (or fast rewind) is automatically set when tape speed is adjusted as in paragraph 2-12-2.

2-8-4 IN REWIND MODE

1. Load a TEAC YTT-8013 test tape on the right reel table and the empty reel on the left reel table, then thread the tape.
2. Stop the right reel by hand and set the deck in the rewind mode.
3. Adjust R255 to obtain a 100g to 120g (3.5oz ~ 4.2oz) value at point B (Obtain a 100g or 3.9oz as far as possible).

2-9 TENSION ARM HEIGHT ADJUSTMENT

1. Thread any standard tape on the deck using a standard empty reels such as TEAC RE-1002.
2. Set the deck in the play mode.
3. Stop left (right) inertia roller's rotation by hand. Adjust by turning the left (right) tension arm height adjusting screw (refer to Fig. 2-10) so that the tape moves in the center of the inertia roller.

NOTE: When adjusting, pay special attention to the relationship between position-detecting shutter and the opening of photo-interrupter to prevent, for example, the shutter from being caught.

4. Release the inertia roller. Fine-adjust the adjusting nut again until there is no tape curling on the tape guide pin between the erase head and the left (right) inertia roller.
5. After Adjusting the height of both left and right tension arms, check that the tape running condition is good by switching between fast forward and rewind modes.
6. If the tape running position is different when the inertia roller stops and when it turns, the condition when the inertia roller is rotating has priority.

2-8-3 FFテンション調整

1. サプライ側のリール(左リール)を固定してFFモードにする(テープを走行させない状態に保つ)。
2. Aの位置にテンテロ・メータを当て、R257をまわしてテンションを110g±10g(できるだけ110gに近い値)に調整する。

参考：FF(REW)時のサプライ側テープ・テンション(バック・テンション)は、2-12-2項に述べるFF REW)テープ・スピード調整により自動的にセットされます。

2-8-4 REWテンション調整

1. サプライ側のリール(右リール)を固定してREWモードにする(テープを走行させない状態に保つ)。
2. Bの位置にテンテロ・メータを当て、R255をまわしてテンションを110g±10g(できるだけ110gに近い値)に調整する。

注：FFとREWのテンションはできるかぎり等しくする。

2-9 テンションアーム高さ調整

1. テッキのモード：PLAY。
2. 調整しようとする側のガイドローラの回転を手で止め、ガイドローラのセンターをテープが走行するようにテンションアーム高さ調整ナット(図2-10参照)を調整する。
3. 手で停止させたガイドローラを放し、ガイドローラと消去ヘッドの間のテープガイドピンの所でテープがカールしないように再度テンションアーム高さ調整ネジを微調整する。
4. 左右のテンションアーム高さ調整後、FF、REWの繰返し動作を行ってテープ走行状態を見る。

注：ガイドローラを停止させた時と回転させた時とでテープ走行位置が変化する場合はガイドローラ回転中のテープ走行を優先する。

Figure shows left side tension arm.
図は左側テンション・アームを示す。

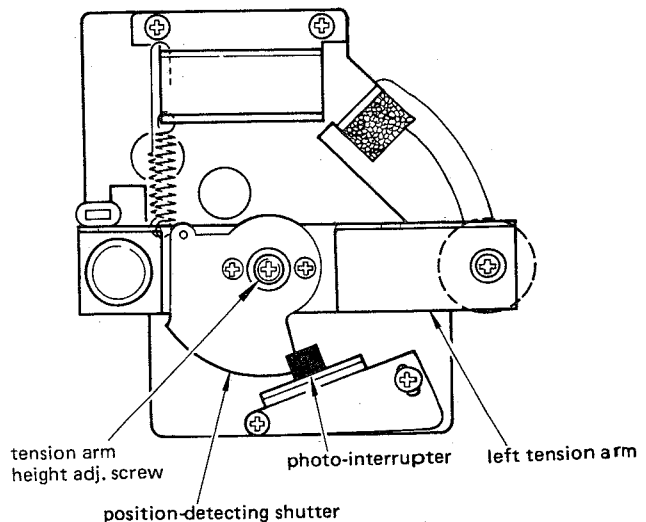

Fig. 2-10

2-10 REEL TABLE HEIGHT ADJUSTMENT

1. Adjust the tension arm height beforehand (See 2-9).
2. Check each reel table height using a TEAC RE-1002 empty reel and letting the tape run in each tape operating mode.
3. If the tape rubs against the reel flanges, adjust the reel table height by means of the two reel table mounting screws.

2-10 リール台高さ調整

1. 前項のテンション・アーム高さ調整後に本調整を行ってください。
2. TEAC RE-1002リールを使用し、各テープ動作でテープがリール・フランジに接触するかどうかをチェックする。
3. もし接触する場合はリール台を固定している2本のネジをゆるめ、リール台取付位置を動かして調整する。

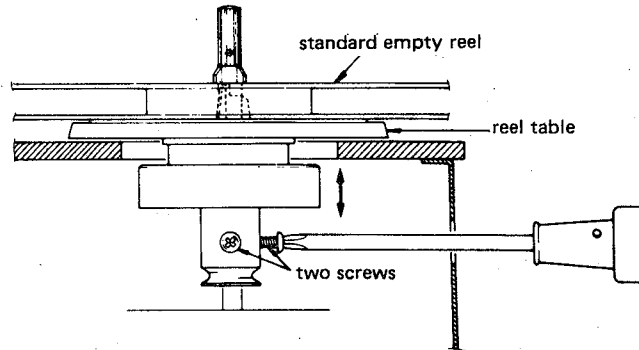

Fig. 2-11

2-11 TAPE PATH ALIGNMENTS

The following procedure is for parallelism adjustment of left pinch roller. A similar procedure is also applied for the right pinch roller.

2-11-1 COARSE ADJUSTMENT OF PINCH ROLLER PARALLELISM

1. Let pinch roller draw near to capstan shaft by manually lifting up tape lifter shown in Fig. 2-12.
2. Check pinch roller/capstan shaft parallelism viewed from direction of arrow A shown in Fig. 2-12. (Refer to Fig. 2-13, 14.)
3. If not parallel, loosen the reinforcement plate screw near the correction-required side (Refer to Fig. 2-15), then correct tilt of pinch roller spindle using correction jig. (Part No. 573600100). Adjustment can be done by tilting correction jig in direction of arrow A or A'.

NOTE:

- (1) Use the jig as near as possible to the pinch roller spindle.
 - (2) Do not touch the surface of spindle.
 - (3) Use no other tool for this adjustment!
4. Remove pinch roller, then push up tape lifter to visually align pinch roller spindle with the capstan shaft viewed from direction of arrow B in Fig. 2-12.
 5. If needed, adjust by tilting correction jig in direction of arrow B or B' in Fig. 2-15.

2-11-2 FINE ADJUSTMENT OF PINCH ROLLER PARALLEL ALIGNMENT

1. Repeat play and stop and confirm tape travel positioning does not vary.
2. If necessary, adjust pinch roller alignment as shown in Fig. 2-15.

2-11 テープ走行調整

ピンチ・ローラとキャプスタン・シャフトとの平行度は、テープ走行の安定に最も重要な事項です。

以下に左ピンチ・ローラの平行度調整の手順を述べますが、右ピンチ・ローラについても同様に調整して下さい。

2-11-1 ピンチ・ローラ平行度の仮調整

1. 図2-12に示すテープ・リフタを手で押し上げ、ピンチ・ローラをキャプスタン・シフトに近づける。
2. 図2-12に示すA方向から見て、ピンチ・ローラとキャプスタン・シャフトの平行度をチェックする。
3. 平行でない場合は、調整棒を使用して図2-15に示す、A又はA'方向にピンチ・ローラ軸の傾きを修正する。(調整棒は出来るだけピンチ・ローラ軸に近い位置にセットして下さい)。(調整棒 品番5736000100)
4. 次にピンチ・ローラを外し、テープ・リフタを上げ、図2-12のB方向から見てピンチ・ローラとキャプスタン・シャフトの平行度をチェックする。
平行でない場合は、調整棒を使用して図2-15に示すB又はB'方向にピンチ・ローラ軸の傾きを修正する。

2-11-2 ピンチ・ローラ平行度微調整

1. PLAY STOPを繰り返しテープ走行位置が変化しないことを確認する。
2. もし変化する場合は図2-15の方法でピンチ・ローラ軸の傾きを微調整する。

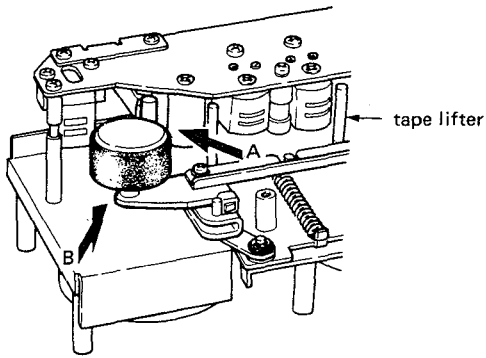

Fig. 2-12 Directions for pinch roller parallelism check

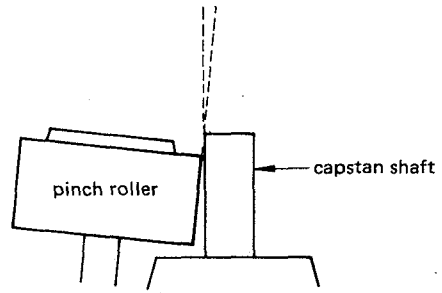

Fig. 2-13 View in direction A (example of non-parallelism)

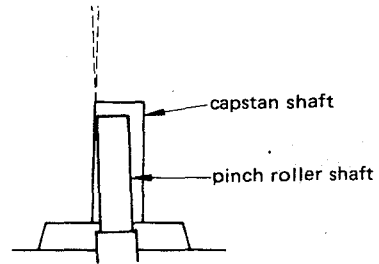

Fig. 2-14 View in direction B (example of non-parallelism)

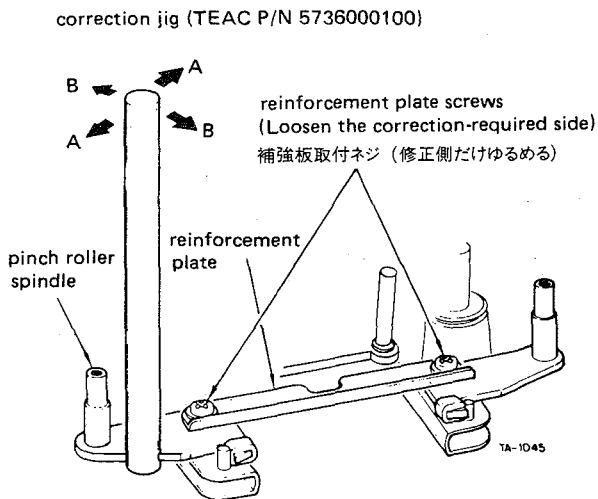

Fig. 2-15 Pinch roller/capstan alignment

2-12 TAPE SPEED ADJUSTMENT

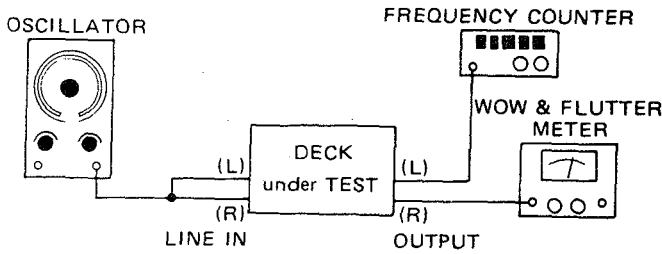

Fig. 2-16

- NOTES:**
1. Conduct all the following in both forward and reverse play modes.
 2. When ordering test tapes, allow for the longer delivery time that is required for them.

2-12-1 PLAY SPEED

1. Connect a frequency counter to either OUTPUT terminal.
2. Load TEAC YTT-2004 (X-2000: YTT-2003) test tape. Set the SPEED switch—HIGH, and PITCH CONT knob—OFF.
3. Play the tape. Adjust HIGH SPEED control (see Fig. 2-17) for a reading of 3,000Hz \pm 5Hz.
4. Check the following at the beginning and the end of the tape.
Specifications:
Tape speed deviation 3,000Hz \pm 30Hz
Tape speed drift 15Hz
5. Change the test tape to a TEAC YTT-2003 (X-2000: YTT-2002), and SPEED switch setting to LOW.
6. Repeat steps 3 through 4. Adjust LOW SPEED control if necessary.
7. Pull the PITCH CONT knob out. Set SPEED switch HIGH. Play a YTT-2004 (X-2000: YTT-2003)
8. Check if the speed variation of at least 3,000Hz \pm 180Hz is obtained when the PITCH CONT knob is rotated fully in both directions.
9. Change the test tape to YTT-2003 (X-2000: YTT-2002), SPEED switch setting to LOW. Repeat step 8.

FAST WINDING SPEED

1. Set the deck in vertical position.
2. Connect oscilloscope between TP1 test point on the POWER PCB and ground.
3. Thread a TEAC YTT-8013 test tape. In this case, either use of 7inch reels or 10inch are permitted provided both left and right reels are the same size.
4. During fast forward or rewind mode, adjust R150(see Fig. 2-9) so that wavelength displayed on the oscilloscope becomes 7msec. (Fig. 2-18). Adjustment should be satisfied at any tape winding position.
5. Check that almost equal value of fast winding speed is obtained between fast forward and rewind modes.

2-12 テープ・スピード調整

2-12-1 FWD/REV PLAYスピード

1. 調整箇所 図2-17参照
2. テープ・スピード調整時、ピッチ・コントロール・スイッチは OFFにしておくこと。
3. 規格
テープ速度偏差 3,000Hz \pm 30Hz
テープ速度変動幅 15Hz以内 (無調整参考値)

2-12-2 FF/REWスピード

1. パワー基板のTP. 1(図2-9参照) にオシロスコープを接続する。
2. デッキをFFモード又はREWモードにする。
3. TP. 1の波形の波長が7m secになるようにR150(図2-9参照) を調整する……図2-18
4. FFとREWで大きな差がないことを確認する。

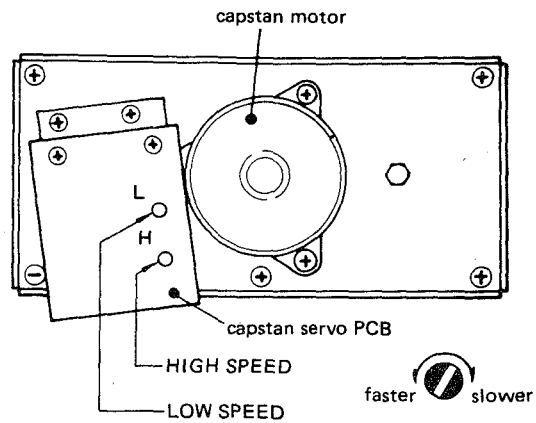

Fig. 2-17 FWD/REV play speed adjustment points

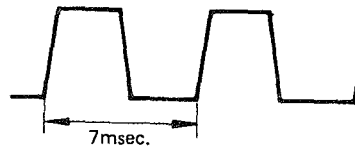

Fig. 2-18 Waveform at TP1

2-13 WOW AND FLUTTER CHECKS

- NOTES:**
1. All the following apply to both forward and reverse play modes.
 2. The following measurements should be made at the beginning and the end of the tape.
 3. When ordering test tapes, allow for the longer delivery time that is required for them.

Playback

1. Connect the test equipment to the deck as shown in Fig. 2-16.
2. Load and play a TEAC YTT-2004 (X-2000: YTT-2003) test tape for HIGH speed (19cm/s or 7-1/2ips), or a TEAC YTT-2003 (X-2000: YTT-2002) test tape for LOW speed (9.5cm/s or 3-3/4ips).
3. Read the indication on the wow and flutter meter.

Specifications:

X-2000M:	HIGH (38cm/s):	0.04% WRMS	0.08% RMS
	LOW (19cm/s):	0.05% WRMS	0.10% RMS
X-2000 :	HIGH (19cm/s):	0.05% WRMS	0.10% RMS
	LOW (9.5cm/s):	0.07% WRMS	0.12% RMS

Overall

4. Load a TEAC YTT-8013 test tape (blank). Apply and record a 3,000Hz signal.
5. During simultaneous tape monitoring (playing) the recorded signal, read the wow and flutter meter display.

Specifications:

X-2000M:	HIGH:	0.10% RMS	LOW:	0.12% RMS
X-2000 :	HIGH:	0.12% RMS	LOW:	0.15% RMS

2-14 LUBRICATION

Oiling is needed after every 1,000 hours of operation or once a year if the deck is infrequently used. For this purpose, TEAC spindle oil (from TEAC TZ-255 oil kit), Mobil D.T.E. Oil Light, etc. are recommended. Lubrication is normally not necessary except at the points shown.

1. Place the deck in the horizontal position.
2. Apply a few drops of oil to the respective spindles shown, excluding capstans, then spread the oil evenly on the spindle surfaces using a cotton cloth, etc.
3. For capstans, apply a few drops to the indicated position.
4. After oiling all the points, leave the deck for 1 to 2 hours until the oil is thoroughly absorbed.

2-15 VOLTAGE CONVERSION (FOR GENERAL EXPORT MODELS)

Frequency Conversion

Since the X-Series uses DC motors, frequency conversion is not necessary.

Voltage Conversion

1. First remove the two feet by removing the screws in each one.
2. Unscrew the left and right sides of the cabinet.
3. Locate the voltage selector as seen from the top side of the deck.
4. Turn the slotted center post of the selector with a screwdriver to match the numerals corresponding to the voltage requirement of your area to the point marked "SET UP VOLTAGE" (click sound is heard).
5. Replace the cabinet and feet.

2-13 ワウ・フラッタ・チェック

使用テープ YTT-2003……………LOW (19cm/sec)

YTT-2004……………HIGH (38cm/sec)

7号リール使用時の巻始め及び巻終りを測定。

テープ速度	再生法		録再法
	RMS	WRMS	RMS
19cm/s	0.10%	0.05%	0.12%
38cm/s	0.08%	0.04%	0.10%

2-14 注油

デッキの回転部分には1000時間使用毎或いは1年に1回程度注油が必要です。

オイルは、TEACスピンドル・オイル(TEAC TZ-255オイル・キット)又はMobil D.T.E.オイル・ライト等を使用してください。

1. デッキを水平位置に置く。
2. テンション・ローラ、ガイド・ローラ、ピンチ・ローラには数滴、キャプスタンには一滴、それぞれ図2-19に矢印で示す個所に注油する。
3. 注油は多過ぎないように、またテープ走行部分にオイルが付着しないよう注意してください。

Figure shows left side. Do also for right side.

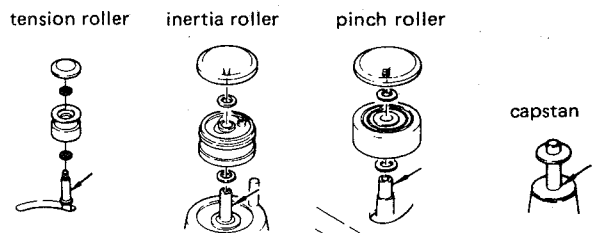

Fig. 2-19

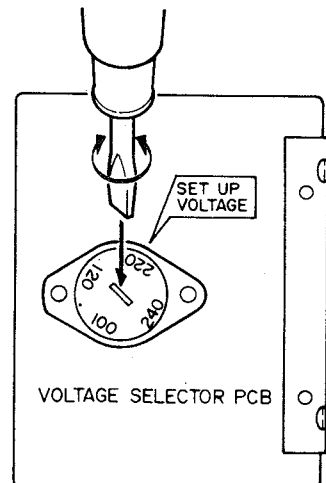

Fig. 2-20

2-16 HEAD ALIGNMENT

There is no need for head height and tilt adjustments because the record and playback heads of X-2000M/X-2000 are a semi-fixed type (erase head fully-fixed).

2-16-1 HEAD MOUNTING (RECORD AND PLAYBACK HEADS)

1. Refer to Fig. 2-22.
2. With head mounting screws, mount heads to head mounting plate. Attach shield case to the playback head.
3. Mount head ass'y to head base using mounting screw and mount tangency adjustment screw.
4. Mount azimuth adjustment screws.

2-16-2 PLAYBACK HEAD ADJUSTMENT

1. See Fig. 2-23 for necessary connections.
2. Set the MONITOR switch to TAPE.
3. Run the test tape TEAC YTT-1003 in play mode to reproduce the 400Hz signal on the tape.
4. Slightly loosen the mounting screws which hold playback head in place and adjust the tangency using adjustment screws, for maximum output. When the maximum output is attained, retighten both mounting screws.
5. Play the 16kHz signal on the tape and adjust the azimuth of the playback head using adjustment screws for less than 45° of phase difference between the two channels (see Fig. 2-25).

NOTE: Azimuth adjustment should be completed by turning adjustment screws in tightening direction (clockwise).

6. Set the PLAYBACK HEAD switch to 4T and perform the same tangency and azimuth adjustment procedures to 4 Track playback head (X-2000M only).

2-16-3 RECORD HEAD ADJUSTMENT

Proceed to record head adjustment only after playback head adjustment has been completed.

1. See Fig. 2-23 for necessary connections.
2. Set the MONITOR switch to TAPE.
3. Load the blank test tape TEAC YTT-8013 (NORMAL) or YTT-8053 (EE) and record a 400Hz, -12dB (195mV) signal in recording mode to reproduce it simultaneously.
4. Adjust the tangency of the recording head as in step 4 under paragraph 2-16-2.
5. Simultaneously record and reproduce a 400Hz, -42dB (6.15 mV) signal and adjust the azimuth of the recording head using adjustment screws for less than 45° of phase difference between the two channels (see Fig. 2-25).

NOTES: ● Azimuth adjustment should be completed by turning adjustment screws in tightening direction (clockwise).
● Be careful not to confuse the bias signal (150kHz) in measurement.

6. Place the deck in reverse recording mode and perform the same tangency and azimuth adjustment procedures to the reverse recording head.

2-16 ヘッド調整

X-2000Mの録音ヘッドと再生ヘッドは準固定式(消去ヘッドは完全固定式)になっています。このためヘッドの高さ調整とチルト調整は不要です。

2-16-1 ヘッド取付(録音ヘッド,再生ヘッド)

1. Fig.2-22参照
2. ヘッド取付ネジでヘッドをヘッド取付板に固定する(ヘッドAss'y)。このとき再生ヘッドにはシールド・ケースをセットする。
3. ヘッドAss'yをヘッド固定ネジとヘッド首振りネジでヘッド・ベースに取付ける。
4. アジマス調整ネジを取付ける。

2-16-2 再生ヘッド調整

1. 接続 Fig.2-23
2. MONITORスイッチTAPE
3. TEAC YTT-1003テープ・テストをPLAYモードで走行させ、400Hz区分を再生する。
4. 再生ヘッドのヘッド固定ネジをやや緩め、ヘッド首振りネジを左右に動かして400Hz再生出力が最大になるようヘッドの首振り角度を調整する。調整終了後両ネジを締める。
5. 次にYTT-1003の16kHz区分を再生し、LchとRchの位相差が45°以内になるようアジマス調整ネジを調整する。(Fig. 2-24)

注. アジマス調整ネジは締める方向(右回し)で調整を終ること。

6. 次にPLAYBACK HEADを4Tにし、上記と同様の手順で、4T再生ヘッドのヘッド首振りとアジマスの調整を行なう。

2-16-3 録音ヘッド調整

録音ヘッド調整の前に再生ヘッド調整が終っていること。

1. 接続 Fig.2-23
2. MONITORスイッチ TAPE
3. TEAC YTT-8013(NORMAL)又はYTT-8053(EE)テープをセットし、400Hz/-12dB(195mV)信号を録音しながら同時再生する。
4. 再生ヘッド調整と同様に録音ヘッドの首振り角度を調整する。
5. 次に10kHz/-42dB(6.15mV)信号を録音再生し、LchとRchの位相差が45°以内になるようアジマス調整する。(Fig.2-24)。

注. ● アジマス調整ネジは締める方向(右回し)で調整を終ること。

- バイアス信号(150kHz)を測定しないよう注意すること。

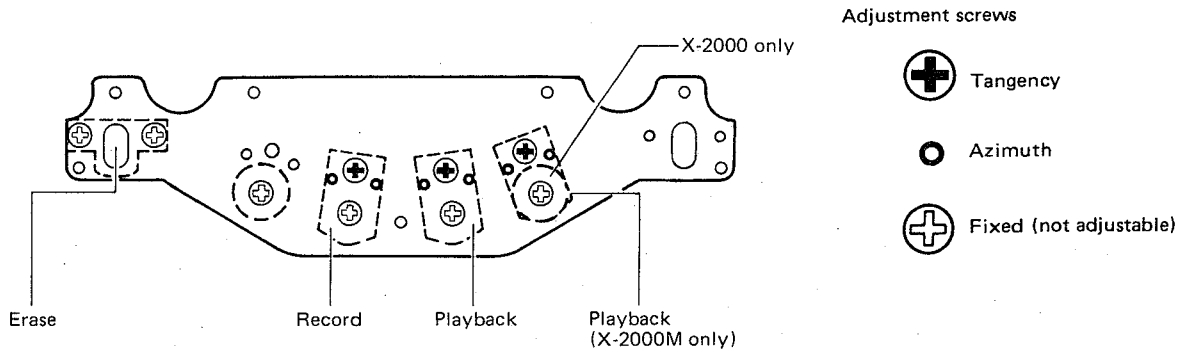

Fig. 2-21 Head arrangement

* X-2000Mでは無調整

<p>*TILT あおり</p> <p>The head surface should be parallel to the tape guide pin surface.</p> <p>ヘッド表面がテープ・ガイドの表面に平行であること。</p>	
<p>AZIMUTH アジマス</p> <p>The gap of the head core should be perpendicular to the tape travel.</p> <p>ヘッド・コアのギャップがテープ走行方向に対して垂直であること。</p>	
<p>*HEIGHT 高さ</p> <p>The upper (lower) core of the head should be level with the upper (lower) edge of the tape.</p> <p>コア上縁(下縁)がテープの上縁(下縁)ヘッドに一致していること。</p>	
<p>TANGENCY 首振り</p> <p>The dotted line should be perpendicular to the surface of the tape.</p> <p>ヘッドの中心線(点線)がテープに垂直であること。</p>	

Fig. 2-22 Head regulation elements

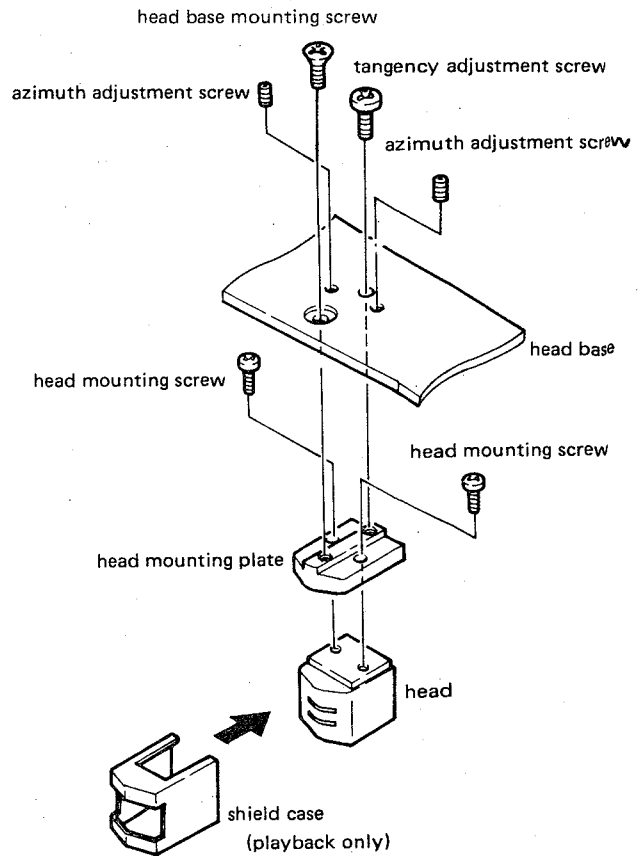

Fig. 2-23 Head mounting

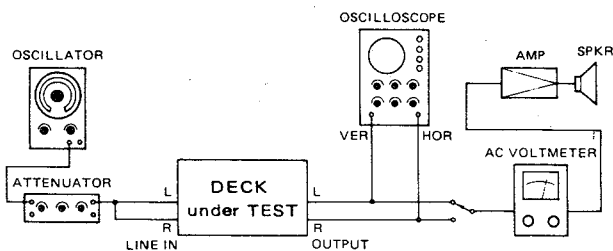

Fig. 2-24 Connection for phase check

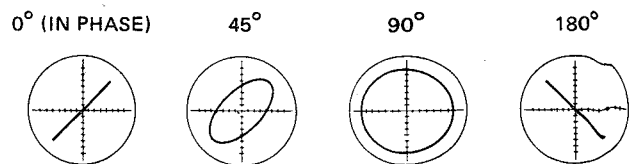

Fig. 2-25 Confirming phase relationship

3 ELECTRICAL ADJUSTMENTS AND CHECKS

アンプ部の調整と確認

3-1 ADJUSTMENT POINTS LOCATION AND CONNECTION

調整箇所と接続

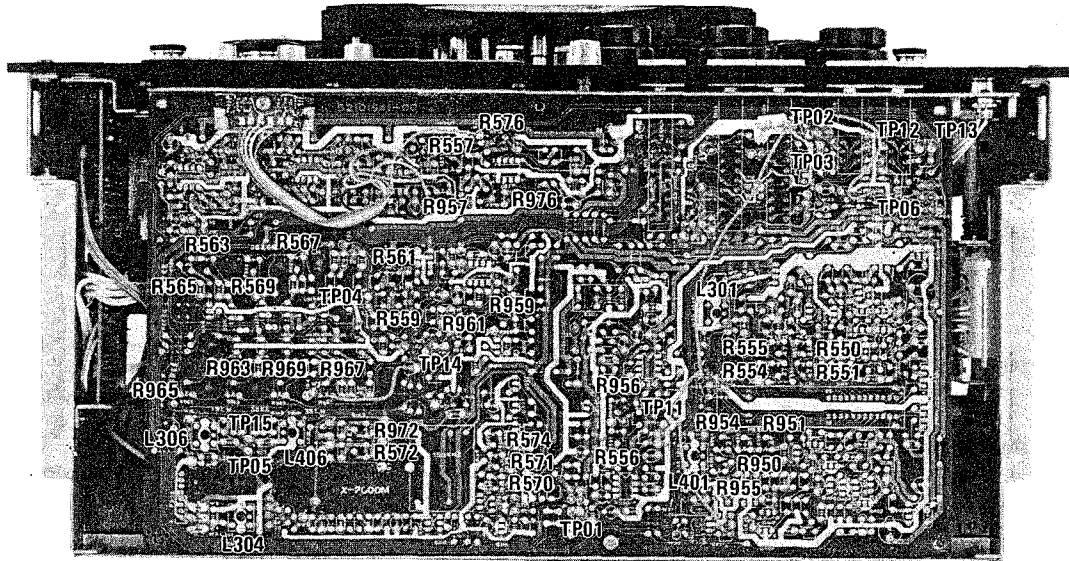

X-2000M

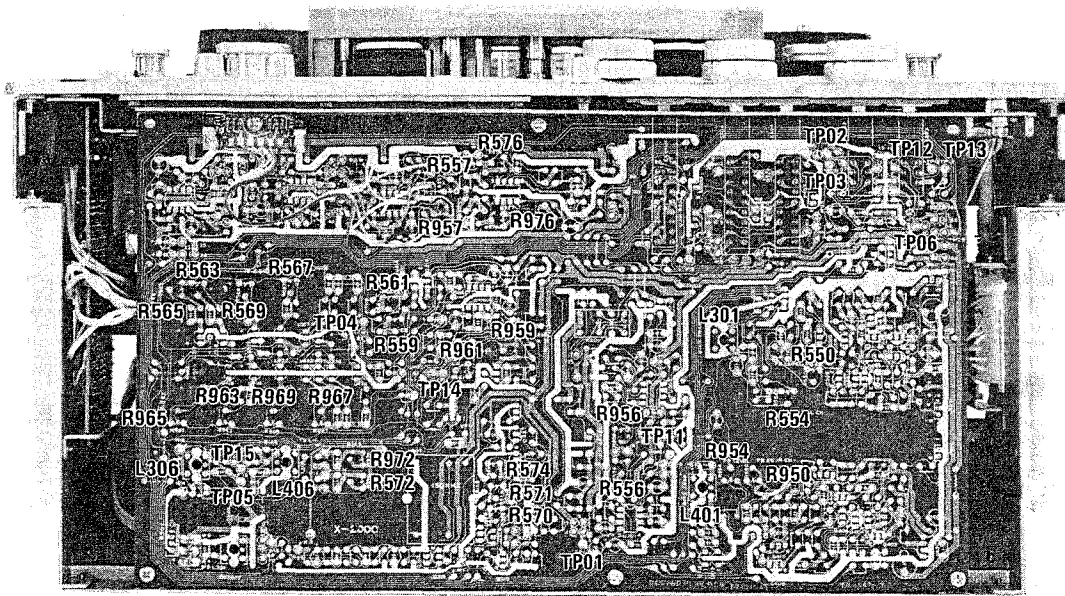

X-2000

R550/R950		Playback EQ	R567/R967	NORMAL	High speed Rec EQ
R551/R951	X-2000M 4T		R569/R969	EE	
R554/R954		Playback level	R570	EE	Low speed Rec bias
R555/R955	X-2000M 4T		R571	NORMAL	
R556/R956		Output level	R572/R972	EE	High speed Rec bias
R557/R957		Input level	R574	NORMAL	
R558/R958		VU meter	R576/R976		Phase shift
R559/R959	EE	Rec level	L301/L401		Bias trap (playback)
R561/R961	NORMAL		L304		Monaural Rec EQ
R563/R963	NORMAL	Low speed Rec EQ	L306/L406		Bias trap (record)
R565/R965	EE				

Fig. 3-1 REC AND PLAY PCB adjustment and test points

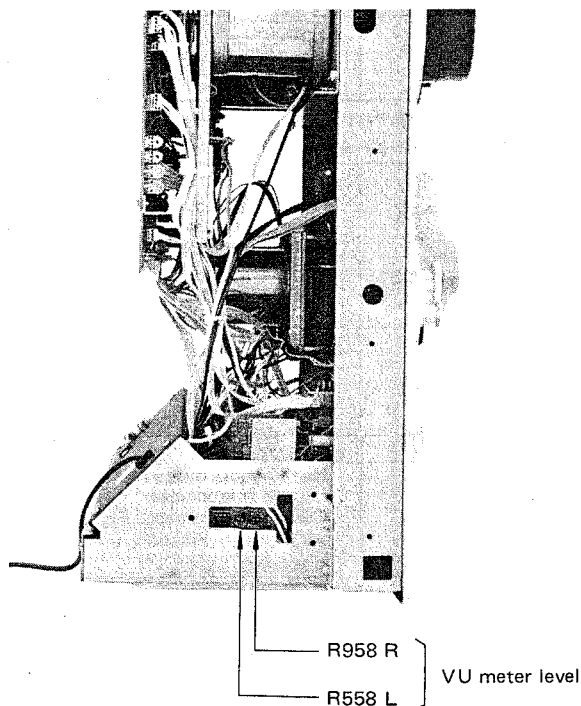

Fig. 3-2 Headphone PCB adjustment points

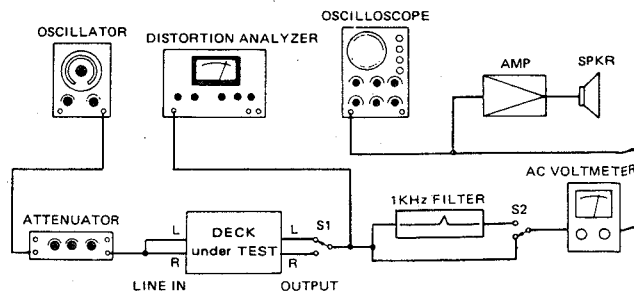

Fig. 3-3 Basic connection

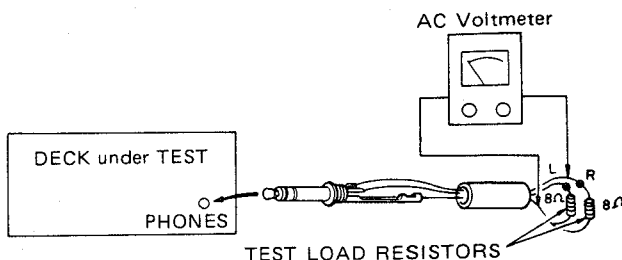

Fig. 3-4 Connection for PHONES level check

NOTES:

1. Before performing adjustments and checks, clean and demagnetize the entire tape path.
2. Check that the deck is properly set for the voltage in your locality.
3. In general, adjustments and checks are done in the order of L-ch then R-ch. Double REF. Nos. indicate L-ch/R-ch. (Example: R371/R372)
4. The value of "dB" refers to 0dB (0.775V). If an AC voltmeter calibrated to 0dB (1V) is to be used, appropriate compensation should be made.
5. The AC voltmeter used in the procedures must have an input impedance of 1M-ohms or more.

注意.

1. アンプ部の調整・確認の前に、テープ走行系の消磁と清掃を行なってください。
2. 特に指定の無い限り、調整はLch, Rchの順序で行なって下さい。
尚R371/R372のように記されている回路番号はLch/Rchを示します。
3. 0dB=0.775V
4. 測定に使用するレベル計の入カインピーダンスは1MΩ以上ものを使用してください。

3-2 PLAYBACK PERFORMANCE 再生系

Initial deck settings

OUTPUT cont.: Max.
MONITOR sw: TAPE
SPEED sw: 19cm/s
TAPE sw: NORMAL
EQ sw: NAB (X-2000M)

TEAC test tapes

YTT-1004: For 38cm/s (15 ips), NORMAL
YTT-1003: For 19cm/s (7-½ ips), NORMAL
YTT-1002: For 9.5cm/s (3-¾ ips), NORMAL
YTT-8013: For S/N check

ITEM 調整項目	SETTING 設定	INPUT SIGNAL 入力信号	ADJUST 調整箇所	RESULT 調整値	REMARKS 備考
1. Playback head azimuth 再生ヘッド・アジマス	1-1 Connection: Fig. 2-24 接続	YTT-1003 (16 kHz/-10 dB)	Azimuth screws アジマス調整ネジ	FWD Phase: within 45° 位相 45°以内	Refer to Fig. 2-21 ~ 25
2. Playback level 再生レベル	2-1 AC voltmeter to REC and PLAY PCB TP.01/TP.11 and GND.	YTT-1003 (400 Hz/0 dB)	R554/R954	TP.01/TP.11 -8 dB (308 mV)	X-2000M 4 Track: R555/R955
	2-2 PLAY mode		R556/R956	OUTPUT: -5 dB (436 mV)	
	2-3 Same as above 同上		OUTPUT cont.	OUTPUT R: -11 dB (218 mV)	
			Check チェック	OUTPUT L: -11 dB ±0.5 dB (206 mV~231 mV)	
	Specified playback condition. IMPORTANT: Do not touch OUTPUT.cont. during later checks. 規定再生状態 注意:以降の調整に於てOUTPUTつまみを動かさないこと				
3. Frequency response 周波数特性	3-1 Spec. PB condition 規定再生状態 SPEED sw: HIGH	X-2000M: YTT-1004 (400 Hz/16 kHz) X-2000: YTT-1003 (400 Hz/10 kHz)	R550/R950 X-2000M 4 Track: R551/R951	OUTPUT: Nearly equal output level (±1.5 dB) at both frequencies. Then check frequency response (Fig. 3-5&3-6) 両周波数の出力がほぼ等しく(±1.5dB)なるよう調整。その後周波数特性をチェック。 (図3-5,3-6参照)	
	3-2 TAPE sw: NORMAL → EE	YTT-1003 (10 kHz)	Check チェック	OUTPUT: At 10 kHz should be approx. 3dB higher than measured in above step. 10kHzの出力が上記より約3dB上昇すること。	
	3-3 SPEED sw: LOW TAPE sw: NORMAL	YTT-1002 (400 Hz/8 kHz)	Check チェック	OUTPUT: Nearly equal output level (±1.5 dB) at both frequencies. Frequency response: Fig. 3-6&3-7 両周波の出力がほぼ等しい(±1.5dB)こと。 周波数特性: 図3-6,3-7	
	3-4 TAPE sw: NORMAL → EE	YTT-1002 (8 kHz)	Check チェック	OUTPUT: At 8 kHz should be approx. 3 dB higher than measured in above step. 8kHzの出力が上記より3dB上昇すること。	
4. Signal to noise ratio S/N比	4-1 Spec. PB condition 規定再生状態	Fully erased YTT-8013 tape (Use bulk tape eraser) バルク・イレーサで充分消磁されたYTT-8013	Check チェック	OUTPUT S/N: X-2000M HIGH: 53 dB LOW: 53 dB X-2000 HIGH: 49 dB LOW: 46 dB	Ratio of reference level (Item 2-3) to noise. 基準信号レベルは2-3項の規定再生レベル。

3.3 MONITOR PERFORMANCE

モニタ系

Deck settings

OUTPUT cont. Specified playback condition. <規定再生状態>

MONITOR sw: SOURCE

ITEM 調整項目	SETTING 設定	INPUT SIGNAL 入力信号	ADJUST 調整箇所	RESULT 調整値	REMARKS 備考	
5. Min. LINE input level LINE最小 入力レベル	5-1	LINE IN: 400 Hz/-22 dB (61.5 mV)	R557/R957	TP.03/TP.13: -2 dB (615 mV)		
	5-2		Check チェック	OUTPUT: -5 dB ±1 dB (388 mV~489 mV)		
6. Min. MIC input level MIC最小 入力レベル	6-1	MIC: 400 Hz/-70 dB (245 μV)	Check チェック	OUTPUT: -5 dB ±3 dB (308 mV~615 mV)		
7. Specified LINE input level LINE規定 入力レベル	7-1	LINE IN: 400 Hz/-12 dB (195 mV)	LINE cont. (L/R)	OUTPUT R: -5 dB (436 mV)		
	7-2		Check チェック	OUTPUT L: -5 dB ±1 dB (388mV~489mV)		
	7-3		LINE cont. (L)	OUTPUT L: -5 dB (436 mV)		
		LINE specified input condition. IMPORTANT: Do not touch LINE cont. during later checks. LINE規定入力状態 注意：以降の調整に於てLINEつまみを動かさないこと。				
8. VU meter メータ指示	8-1	LINE spec. input condition LINE規定入力状態	LINE IN: 400 Hz/- 12 dB (195 mV)	R558/R958	VU meter: 0 VU	
9. PHONES input level ヘッドホン出力レベル	9-1	Same as above 同上	LINE IN: 400 Hz/-12 dB (195 mV)	Check チェック	PHONES jack: -8.8 dB ±2 dB (224 mV~354mV)	8Ω load Fig. 3-4

3-4 RECORDING PERFORMANCE

録音系

Deck settings

REC MODE sw: L & R both ON

DBX sw: OUT

SPEED sw: HIGH

TAPE sw: EE

MONITOR sw: TAPE

EQ sw: NAB (X-2000M)

OUTPUT cont.: Spec. PB Condition

LINE cont.: Spec. input condition

MIC cont.: Min

BIAS FINE cont.: Center

TEAC test tape

YTT-8013: Blank tape for NORMAL

YTT-8053: Blank tape for EE

ITEM 調整項目	SETTING 設定	INPUT SIGNAL 入力信号	ADJUST 調整箇所	RESULT 調整値	REMARKS 備考	
10. Bias trap バイアス・トラップ	10-1	AC voltmeter between TP.05/TP.15 and GND YTT-8053	No signal 無信号	L306/L406	TP.05/TP.15: Min. reading バイアス漏れ 最小	Bias frequency バイアス周波数 150 kHz
	10-2	AC voltmeter between TP.01/TP.11 and GND YTT-8053	No signal 無信号	L301/L401	TP.01/TP.11: Min. reading バイアス漏れ 最小	
11. Record bias 録音バイアス	First set adjustor fully CCW (☺), then adjust. 最初に半固定抵抗を左一杯にまわしておいてから調整を始める。					
	11-1	YTT-8053 SPEED sw: HIGH TAPE sw: EE	LINE IN: 7 kHz/-42 dB (6.15 mV)	R572/R972	OUTPUT: Over-bias value オーバー・バイアス値 2.5 dB	X-2000
12. EE record level EE録音レベル	12-1	YTT-8053 SPEED sw: HIGH TAPE sw: EE	LINE IN: 400 kHz/-12 dB (195 mV)	R559/R959	OUTPUT: -5 dB (436 mV)	
	12-2	Same as above 同上 DBX sw: IN		Check チェック	VU meter: 0 VU ±0.5 VU	
	12-3	Same as above 同上 DBX sw: IN		Check チェック	OUTPUT: -5 dB ±1.5 dB (367 mV~518 mV)	
	12-4	Same as above 同上 DBX sw: OUT MONITOR sw: TAPE/SOURCE	No signal 無信号	Check チェック	OUTPUT: Bias leak: バイアス漏れ less than -51 dB (2.18 mV)	
	X-2000M: After adjusting overall frequency response (items 14 and 15), re-do this item's checks and adjustments. 本確認・調整は録再周波数特性調整(14, 15項)後、再度行うこと。					
13. Record head azimuth 録音ヘッド・アジマス	13-1	YTT-8053 SPEED sw: HIGH TAPE sw: EE DBX sw: OUT MONITOR sw: TAPE	LINE IN: 400 Hz/-12 dB (195 mV)	Record head azimuth screws 録音ヘッド・ア ジマス調整ネジ	Phase 位相 :0°	Refer to Fig. 2-21 ~ 25
		アジマス調整ネジを動かした場合は12-1~3項を再チェックすること。				

ITEM 調 整 項 目	SETTING 設 定	INPUT SIGNAL 入 力 信 号	ADJUST 調 整 個 所	RESULT 調 整 値	REMARKS 備 考	
14. EE frequency response EE周波数特性 (SPEED: HIGH)	14-1		X-2000M LINE IN: 400 Hz & 30 kHz alternately 交互信号 /-32 dB (19.5 mV)	R572/R972 R569/R969 (for EQ fine) 微調用	OUTPUT: Equal level at both frequency 両周波数の出力が等しくなるよう調整。	
	14-2		X-1000 LINE IN: 400 Hz & 20 kHz alternately 交互信号 /-42 dB (6.15 mV)	R569/R969		
	14-3	Same as above 同上 X-2000M R569/R969: Fully CW. 時計方向いっぱい。	X-2000 only LINE IN: 400 Hz & 10 kHz alternately 交互信号 /-42 dB (6.15 mV)	OUTPUT: Output level of the 10 kHz signal should be within ± 1.5 dB with regards to the 400 kHz-signal output level. If the level is lower than -1.5 dB, correct it by cutting off R596/R996. 400Hzの出力レベルに対し、10kHzの出力レベルが ± 1.5 dB以内であること。もし -1.5 dBよりレベルが低い場合はR596/R996をカットして調整。		
	14-4		LINE IN: X-2000M: -32 dB X-2000: -42 dB	Check チェック	Frequency response: Fig. 3-8&3-9 周波数特性: 図3-8, 3-9	
	14-5		Same as above 同上 DBX sw: IN	LINE IN: X-2000M: -32 dB X-2000: -42 dB	Check チェック	Frequency response: Fig. 3-11&3-12 周波数特性: 図3-11, 3-12
	X-2000M: Since record level varies after making this item instruction adjustment, re-do checks and adjustments shown in item 12. 本調整後、録音レベルが変わるので、再度12項の確認・調整を行うこと。					
15. EE frequency response EE周波数特性 (SPEED: LOW)	15-1		X-2000M LINE IN: 400 Hz & 20 kHz alternately 交互信号 /-32 dB (19.5 mV)	R570 R565/R965 (for EQ fine) 微調用	OUTPUT: Equal level at both frequency 両周波数の出力が等しくなるよう調整。	
	15-2		X-2000 LINE IN: 400 Hz & 5 kHz alternately 交互信号 /-42 dB (6.15 mV)	R570		
	15-3	YTT-8053 SPEED sw: LOW TAPE sw: EE DBX sw: OUT MONITOR sw: TAPE X-2000M R565/R965: Fully CW. 時計方向いっぱい。	X-2000 only LINE IN: 400 Hz & 20 kHz alternately 交互信号 /-42 dB (6.15 mV)	R565/R965	Same as above 同上	
	15-4		LINE IN: X-2000M: -32 dB X-2000: -42 dB	Check チェック	Frequency response: Fig. 3-9&3-10 周波数特性: 図3-9, 3-10	
	15-5		Same as above 同上 DBX sw: IN	LINE IN: X-2000M: -32 dB X-2000: -42 dB	Check チェック	Frequency response: Fig.3-12&3-13 周波数特性: 図3-12, 3-13
	X-2000M: Since record level varies after making this item instruction adjustment, re-do checks and adjustments shown in item 12. 本調整後、録音レベルが変わるので、再度12項の確認・調整を行うこと。					

ITEM 調整項目		SETTING 設定	INPUT SIGNAL 入力信号	ADJUST 調整箇所	RESULT 調整値	REMARKS 備考
16. NORMAL frequency response NORMAL 周波数特性 (SPEED: HIGH)	16-1	YTT-8013 SPEED sw: HIGH TAPE sw: NORMAL DBX sw: OUT MONITOR sw: TAPE X-2000M R567/R967: Fully CW. 時計方向いっぱい。	X-2000M LINE IN: 400 Hz & 20 kHz alternately 交互信号 /-32 dB (19.5 mV)	R574 R567/R967 (for EQ fine) (微調用)	OUTPUT: Equal level at both frequency 両周波数の出力が等しくなるよう調整。	
	16-2		X-2000 LINE IN: 400 Hz & 10 kHz alternately 交互信号 /-42 dB (6.15 mV)	R574		
	16-3		X-2000 LINE IN: 400 Hz & 20 kHz alternately 交互信号 /-42 dB (6.15 mV)	R567/R967	Same as above 同上	
	16-4		LINE IN: X-2000M: -32 dB X-2000: -42 dB	Check チェック	Frequency response: Fig. 3-8&3-9 周波数特性: 図3-8, 3-9	
	16-5		Same as above 同上 DBX sw: IN	LINE IN X-2000M: -32 dB X-2000: -42 dB	Check チェック	Frequency response: Fig. 3-11&3-12 周波数特性: 図3-11, 3-12
17. NORMAL record level NORMAL 録音レベル	17-1	Same as above 同上 DBX sw: OUT	LINE IN: 400 Hz / -12 dB (195 mV)	R561/R961	OUTPUT: -5 dB (436 mV)	
	17-2			Check チェック	VU meter: 0 VU \pm 0.5 VU	
	17-3			Check チェック	OUTPUT: -5 dB \pm 1.5 dB (367 mV ~ 518 mV)	
	17-4	Same as above 同上 DBX sw: OUT MONITOR sw: TAPE/SOURCE	No signal 無信号	Check チェック	OUTPUT: Bias leak バイアス漏れ less than -51 dB (2.18 mV)	
X-2000M: After adjusting overall frequency response (items 16 and 18), re-do this item's checks and adjustments. 本確認・調整は録再周波数特性調整(16, 18項)後、再度行うこと。						
18. NORMAL frequency response NORMAL 周波数特性 (SPEED: LOW)	18-1	YTT-8013 SPEED sw: LOW TAPE sw: NORMAL DBX sw: OUT MONITOR sw: TAPE X-2000M R563/R963: Fully CW. 時計方向いっぱい。	X-2000M LINE IN: 400 Hz & 20 kHz alternately 交互信号 /-32 dB (19.5 mV)	R571 R563/R963 (for EQ fine) (微調用)	OUTPUT: Equal level at both frequency 両周波数の出力が等しくなるよう調整。	
	18-2		X-2000 LINE IN: 400 Hz & 5 kHz alternately 交互信号 /-42 dB (6.15 mV)	R571		
	18-3		LINE IN: 400 Hz & 20 kHz alternately 交互信号 /-42 dB (6.15 mV)	R563/R963	Same as above 同上	
	18-4		LINE IN: X-2000M: -32 dB X-2000: -42 dB	Check チェック	Frequency response: Fig. 3-9&3-10 周波数特性: 図3-9, 3-10	
	18-5		Same as above 同上 DBX sw: IN	LINE IN: X-2000M: -32 dB X-2000: -42 dB	Check チェック	Frequency response: Fig. 3-12&3-13 周波数特性: 図3-12, 3-13
X-2000M: Since record level varies after making this item instruction adjustment, re-do checks and adjustments shown in item 17. 本調整後、録音レベルが変わるので、再度17項の確認・調整を行うこと。						

ITEM 調整項目	SETTING 設定	INPUT SIGNAL 入力信号	ADJUST 調整箇所	RESULT 調整値	REMARKS 備考		
19. Monaural recording モノラル録音	19-1	YTT-8013 SPEED sw: LOW TAPE sw: NORMAL DBX sw: OUT MONITOR sw: TAPE REC MODE sw: L: ON R: OFF	LINE IN: -42 dB (6.15 mV)	L304	Frequency response 周波数特性: 図3-9, 3-10 Fig.3-9&3-10		
	19-2	Same as above 同上 REC MODE sw: L: OFF R: ON		Check チェック			
20. BIAS FINE バイアス・ファイン	20-1	YTT-8013 SPEED sw: LOW TAPE sw: NORMAL DBX sw: OUT MONITOR sw: TAPE REC MODE sw: ON	LINE IN: 16 kHz/-42 dB (6.15 mV)	Assume an output reference level obtained when the BIAS FINE button is set to center. Turn BIAS FINE completely to left and right and check that output level varies between -3 dB and +2 dB or higher against the reference level. BIAS FINEつまみがセンタ位置の時の出力を基準レベルとする。BIAS FINEつまみを左右一杯にまわしたときの出力レベルが基準レベルに対し+2/-3dB以上変化することをチェックする。			
			After checking, be sure to set BIAS FINE back to the center position. チェック後BIAS FINEつまみをセンタ位置に戻しておくこと。				
21. Distortion 歪率	21-1	Same as above 同上 SPEED sw: HIGH	LINE IN: 400 Hz/-18 dB (97.5 mV)	Check チェック	DBX sw: both IN & OUT TAPE sw: both EE & NORMAL Tortal harmonic distortion 全高調波歪 (0.8%以下) less than 0.8 %		
22. Signal to noise ratio check S/Nチェック	22-1	YTT-8053 & YTT-8013 SPEED sw: HIGH&LOW TAPE sw: EE&NORMAL DBX sw: OUT	No signal 無信号	Output noise levels when "no-signal" recording is played back (S/N zero reference level corresponds to -5 dB of noise level) 無信号録音後テープを巻戻して、再生した時の出力雑音レベル (S/Nの基準レベルは-5dB)			
				SPEED	TAPE	X-2000M	X-2000
				HIGH	YTT-8053	55 dB	52 dB
				LOW	YTT-8013	52 dB	49 dB
23. Erase efficiency 消去効果	23-1	<ul style="list-style-type: none"> Record a 1 kHz signal, rewind and erase a portion of the recording. Playback the tape to compare the output level from the original 1 kHz recording with the level from the erased portion. 1kHz信号を録音後巻戻して一部を消去、未消去部分と消去部分の1kHz出力レベル差を測定。 Connection is same as in Fig. 3-3, but engage 1 kHz filter. 1kHz B.P.F.使用 The worst value should be within spec. 最悪値が仕様を満足すること。 Specifications should be met even when BIAS FINE is turned down to its minimum setting. BIAS FINEつまみ最小でも仕様を満足すること。 					
		Same as above 同上	LINE IN: 1 kHz/-2 dB (615 mV)	Check チェック	Each tape and speed 各テープと速度 68 dB min. ratio		
24. Channel separation チャンネルセパレーション	24-1	<ul style="list-style-type: none"> Connection: Fig. 3-3, but do not connect LINE IN (R), and engage 1 kHz filter. 1kHz B.P.F.使用 Set the deck to record mode. Find the difference between the 1 kHz recorded portion (L ch) and the "no-signal" portion (R ch). Then change the connection and check reverse portion. 1kHz録音部分(Lch)と無信号録音部分(Rch)の1kHz再生出力レベルの差を測定。L,Rを入れ替えた場合についてもチェック。 					
		YTT-8053 SPEED sw: HIGH TAPE sw: EE	LINE IN: Lch: 1kHz/-12dB (195 mV) Rch: No signal	Check チェック	50 dB min. ratio		
25. Adjacent track crosstalk トラック間クロストーク X-2000 only	25-1	<ul style="list-style-type: none"> Record a 125 Hz signal on R channel in recording mode. Play the tape in playback mode to measure output level from L channel and compare it with output level from R channel. Rchに125Hzを録音し、その再生出力を基準レベルとする。次にそのテープを再生し、Lchの再生出力と基準レベルとの差を測定。 Perform the same procedures in reverse recording and playback modes. Check also Lch to Rch crosstalk. またLchについても同様にチェック。 					
		YTT-8053 SPEED sw: HIGH TAPE sw: EE	LINE IN: L ch: No signal R ch: 125Hz/-12dB (195 mV)	Check チェック	40 dB min. ratio		

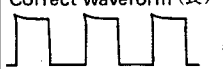
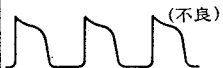
ITEM 調整項目	SETTING 設定	INPUT SIGNAL 入力信号	ADJUST 調整箇所	RESULT 調整値	REMARKS 備考
26. REC MUTE function REC MUTE効果	26-1	<ul style="list-style-type: none"> ● Connection: Fig. 3-3, but engage 1 kHz filter. 1kHz P.B.F使用 ● Record a 1 kHz signal. Push REC MUTE button for several seconds. (At this time, make sure LED on the button lights). Rewind and play the tape. Find the difference between the 1 kHz portion and "rec-mute" portion. 1kHzを録音し、途中でREC MUTE鈕を押して無信号部分を作る。このテープを再生し録音部分と無信号部分との出力レベル差を測定する。			
		YTT-8053 SPEED sw: HIGH TAPE sw: EE	LINE IN: 1 kHz/-2 dB (615 mV)	Check チェック	65 dB min. ratio
27. Phase shift フェーズ・シフト	27-1	YTT-8013 SPEED sw: HIGH TAPE sw: NORMAL	LINE IN: 1 kHz Sawtooth /-12 dB 矩形波	R576/R976	Correct waveform (良)  Incorrect waveform (不良) 

3-5 FREQUENCY RESPONSE

周波数特性

3-5-1 PLAYBACK

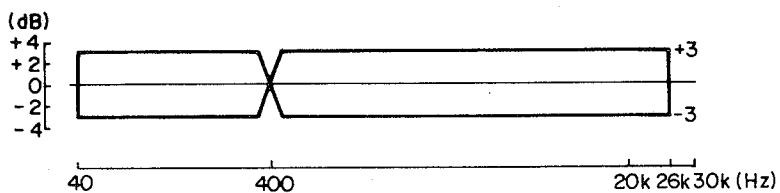

Fig. 3-5 Playback frequency response (38cm/s)

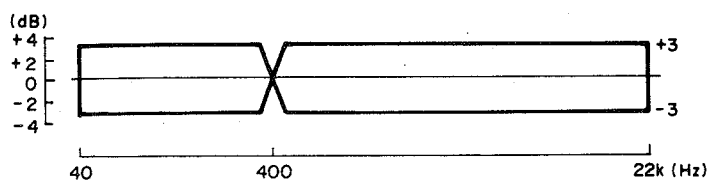

Fig. 3-6 Playback frequency response (19cm/s)

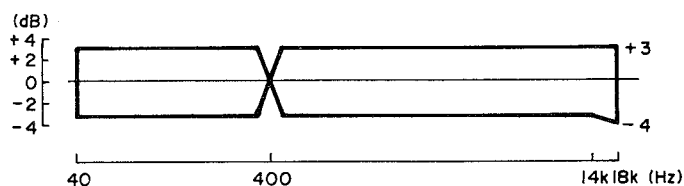

Fig. 3-7 Playback frequency response (9.5cm/s)

3-5-2 OVERALL

YTT-8013, NORMAL ———
 YTT-8053, EE - - - - -

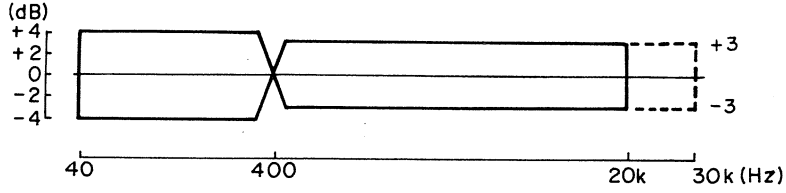

Fig. 3-8 Overall frequency response (38cm/s)

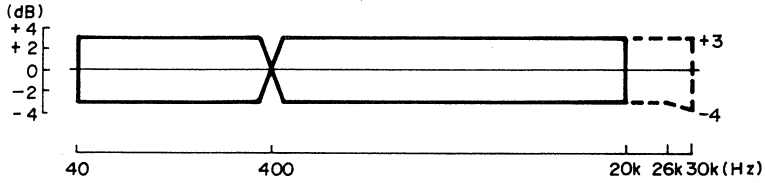

Fig. 3-9 Overall frequency response (19cm/s)

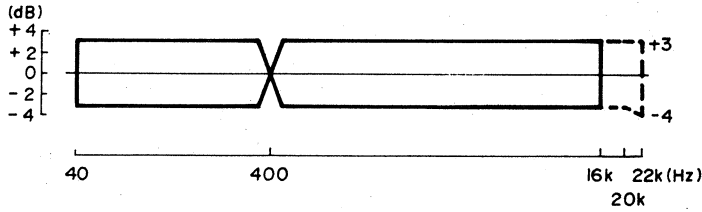

Fig. 3-10 Overall frequency response (9.5cm/s)

3-5-3 OVERALL WITH DBX IN

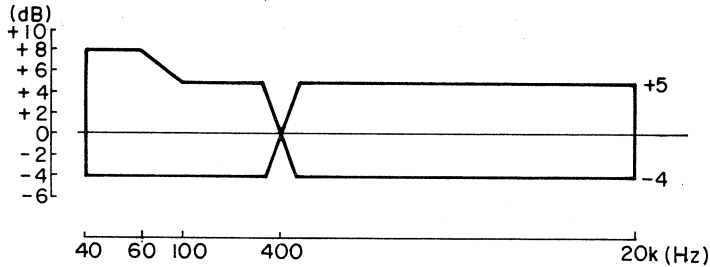

Fig. 3-11 Overall frequency response with DBX IN (38cm/s)

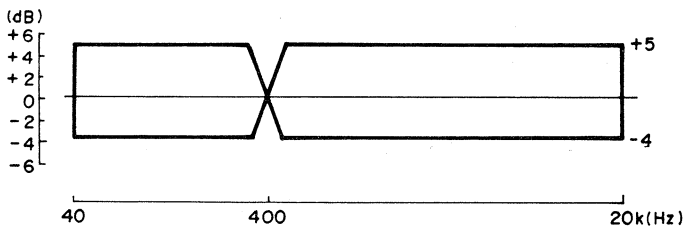

Fig. 3-12 Overall frequency response with DBX IN (19cm/s)

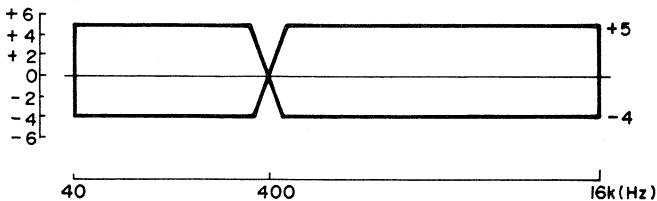

Fig. 3-13 Overall frequency response with DBX IN (9.5cm/s)

3-6 DBX PCB ADJUSTMENT

NOTES:

1. This section adjustment is not usually needed unless an adjustor(s) have been changed or a component(s) on the PC board have sustained damage, since the PC board has been precisely adjusted in the factory.
2. Turn the deck OFF to prevent accidental damage when removing or replacing PC board.

3-6 DBX基板単体調整

注意

1. DBX基板の部品交換を行なった場合の他、通常はDBX基板単体の調整は不要です。
2. 基板やコネクタを外す場合は必ずデッキの電源を切ってから行なってください。

3-6-1 ADJUSTMENT POINTS LOCATION

調整個所

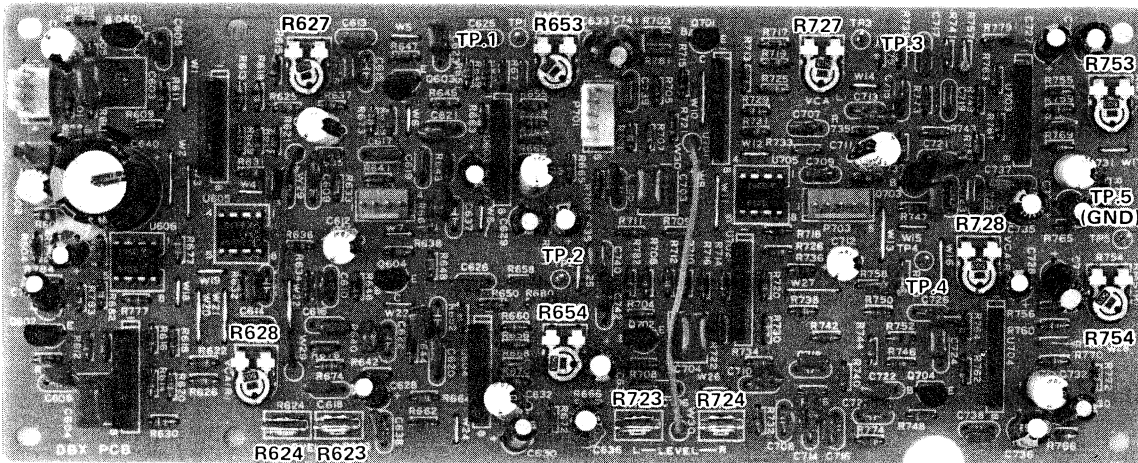

	Lch/Rch		
ENCODER (エンコーダ)	R727/R728	VCA symmetry	VCA シンメトリー
	R723/R724	Nominal level	基準レベル
	R753/R754	RMS symmetry	RMS シンメトリー
DECODER (デコーダ)	R627/R628	VCA symmetry	VCA シンメトリー
	R623/R624	Nominal level	基準レベル
	R653/R654	RMS symmetry	RMS シンメトリー

Fig. 3-14

3-6-2 VCA SYMMETRY ADJUSTMENT WAVE FORM

VCA シンメトリー調整波形

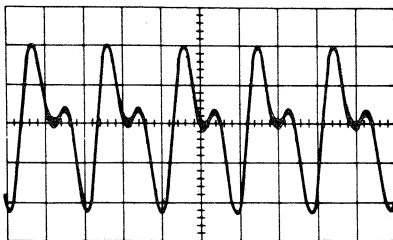

Fig. 3-15 RMS symmetry adjustment (incorrect)
(RMSシンメトリー調整・不良)

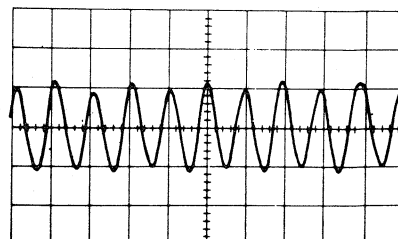

Fig. 3-16 RMS symmetry adjustment (correct)
(RMSシンメトリー調整・良)

3-6-3 DECODER ADJUSTMENT デコーダ調整

ITEM 調整項目	SETTING 設定	INPUT SIGNAL 入力信号	ADJUST 調整箇所	RESULT 調整値	REMARKS 備考
1. Preparation 準備	Preset each of the trimmers of the decoder section on the PCB to their approximate center positions. 各半固定抵抗をセンター位置にする。				
2. RMS SYM	Fig. 3-17	P601-1/P601-4 100 Hz/-8.2 dB (300 mV)	R653/R654	TP.1/TP.2: Clean 200 Hz sine-wave 出力波形が200Hzの正弦波になるよう調整。	Refer to Figs. 3-15 and 3-16.
3. VCA SYM	Fig. 3-18	TP.1/TP.2 Staircase waveform 階段波	R627/R628	P603-1/P603-4 A relatively straight horizontal line on the 'scope face'. (Level variation: 5 mV or less) モニタ波形がほぼ一直線(5mV以下)になるよう調整。	
4. Decoding level 基準レベル調整	Fig. 3-19	P601-1/P601-4 1 kHz/-8.2 dB (300 mV)	R623/R624	P603-1/P603-4 -8.2 dB (300 mV)*	*Reference 1 基準レベル1
5. Operation level デコード効果チェック	Fig. 3-19	P601-1/P601-4 1 kHz/-18.2 dB (95.4 mV)	Check チェック	P603-1/P603-4 -20 dB ±1 dB against Ref. 1 (26.9 mV ~ 33.8 mV)	基準レベル1からの変化。
		P601-1/P601-4 1 kHz/+1.8 dB (95.4 mV)	Check チェック	P603-1/P603-4 +20 dB ±1 dB against Ref. 1 (2.67 V ~ 3.38 V)	
6. Frequency response 周波数特性	Fig. 3-19	P601-1/P601-4 100 Hz/-8.2 dB (300 mV)	Check チェック	P603-1/P603-4 +5 dB ±1 dB against Ref. 1 (477 mV ~ 602 mV)	基準レベル1からの変化。
		P601-1/P601-4 10 kHz/-8.2 dB (300 mV)	Check チェック	P603-1/P603-4 +9.4 dB ±1 dB against Ref. 1 (793 mV ~ 997 mV)	

3-6-4 ENCODER ADJUSTMENT エンコーダ調整

ITEM 調整項目	SETTING 設定	INPUT SIGNAL 入力信号	ADJUST 調整箇所	RESULT 調整値	REMARKS 備考
7. Preparation 準備	Preset each of the trimmers of the encoder section on the PCB to their approximate center positions. 各半固定抵抗をセンター位置にする。				
8. RMS SYM	Fig. 3-20	P701-1/P701-5 100 Hz/-8.2 dB (300 mV)	R753/R754	TP.3/TP.4 Clean 200 Hz sine-wave 出力波形が200Hzの正弦波になるよう調整。	Refer to Figs. 3-15 and 3-16.
9. VCA SYM	Fig. 3-21	TP.3/TP.4 Staircase waveform 階段波	R727/R728	P703-1/P703-5 A relatively straight horizontal line on the 'scope face'. (Level variation: 5 mV or less) モニタ波形がほぼ一直線(5mV以下)になるよう調整。	
10. Encoding level 基準レベル調整	Fig. 3-22	P701-1/P701-5 1 kHz/-8.2 dB (300 mV)	R723/R724	P703-1/P703-5 -8.2 dB (300 mV)*	*Reference 2 基準レベル2
11. Operation level エンコード効果チェック	Fig. 3-22	P701-1/P701-5 1 kHz/-68.2 dB (3 mV)	Check チェック	P703-1/P703-5 -30 dB ±0.5 dB against Ref. 2 (9.54 mV ~ 10.1 mV)	基準レベル2からの変化。
		P701-1/P701-5 1 kHz/+11.2 dB (3 V)	Check チェック	P703-1/P703-5 +10 dB ±0.5 dB against Ref. 2 (900 mV ~ 1.01 V)	
12. Frequency response 周波数特性	Fig. 3-22	P701-1/P701-5 100 Hz/-8.2 dB (300 mV)	Check チェック	P703-1/P703-5 -2.5 dB ±0.5 dB against Ref.2 (213 mV ~ 240 mV)	基準レベル2からの変化。
		P701-1/P701-5 10 kHz/-8.2 dB (300 mV)	Check チェック	P703-1/P703-5 -4.7 dB ±0.5 dB against Ref. 2 (166 mV ~ 186 mV)	

3-6-5 CONNECTIONS

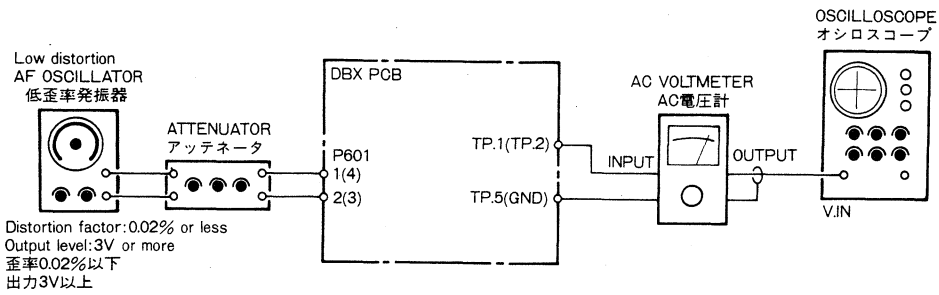

Fig. 3-17 RMS symmetry adjustment setup (decoder)

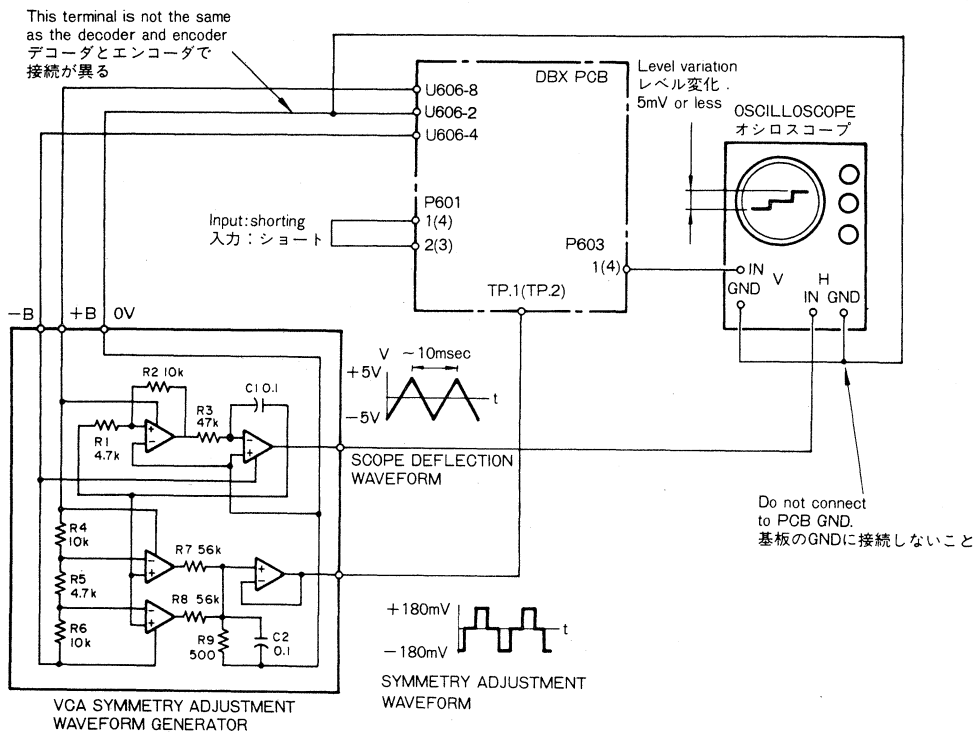

Fig. 3-18 VCA symmetry adjustment setup (decoder)

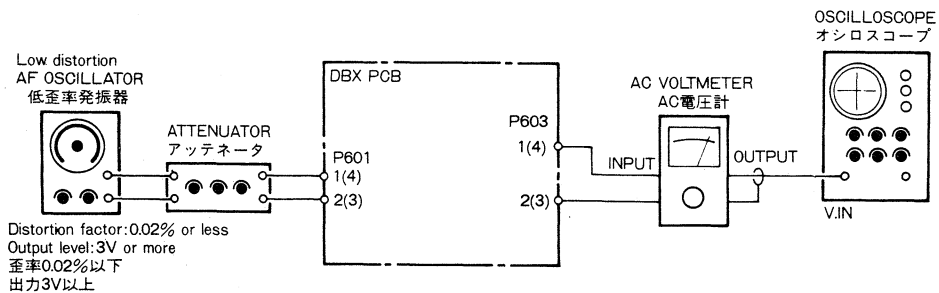

Fig. 3-19 Decoding level adjustment setup (decoder)

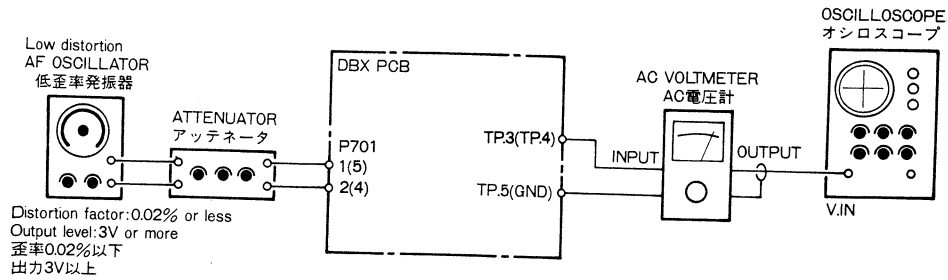

Fig. 3-20 RMS symmetry adjustment setup (encoder)

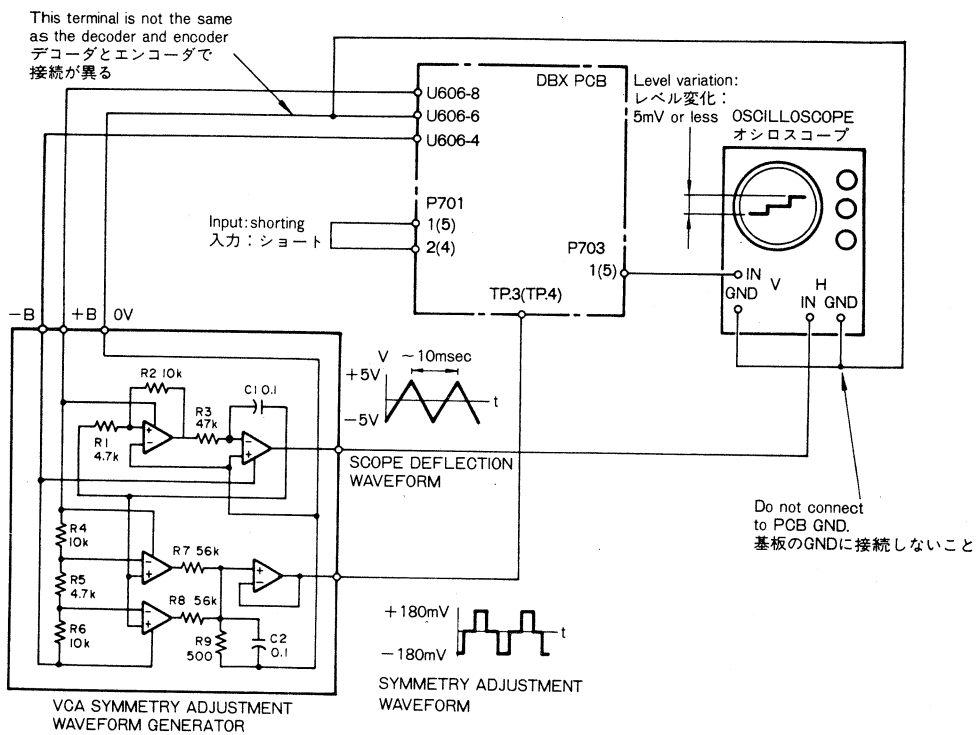

Fig. 3-21 VCA symmetry adjustment setup (encoder)

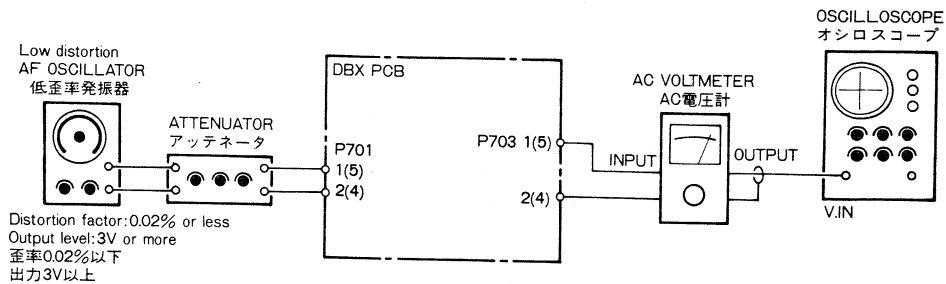
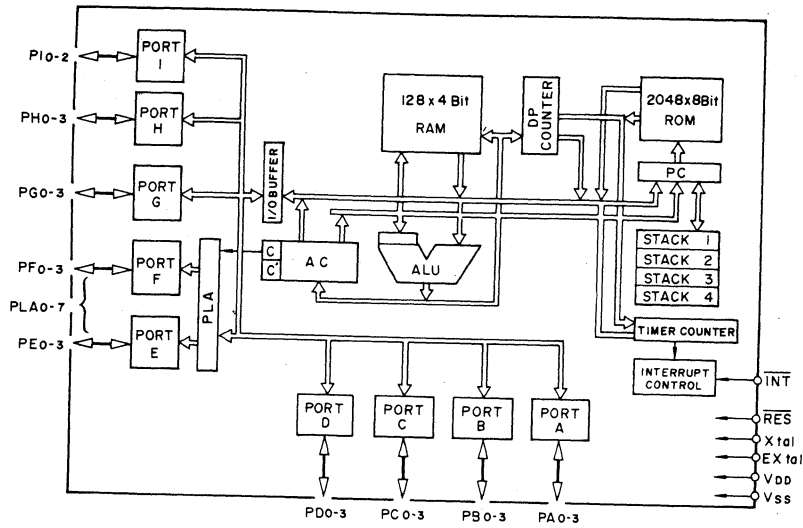

Fig. 3-22. Decoding level adjustment setup (encoder)

3-7 IC BLOCK DIAGRAMS

LM6402H-325



LB1475

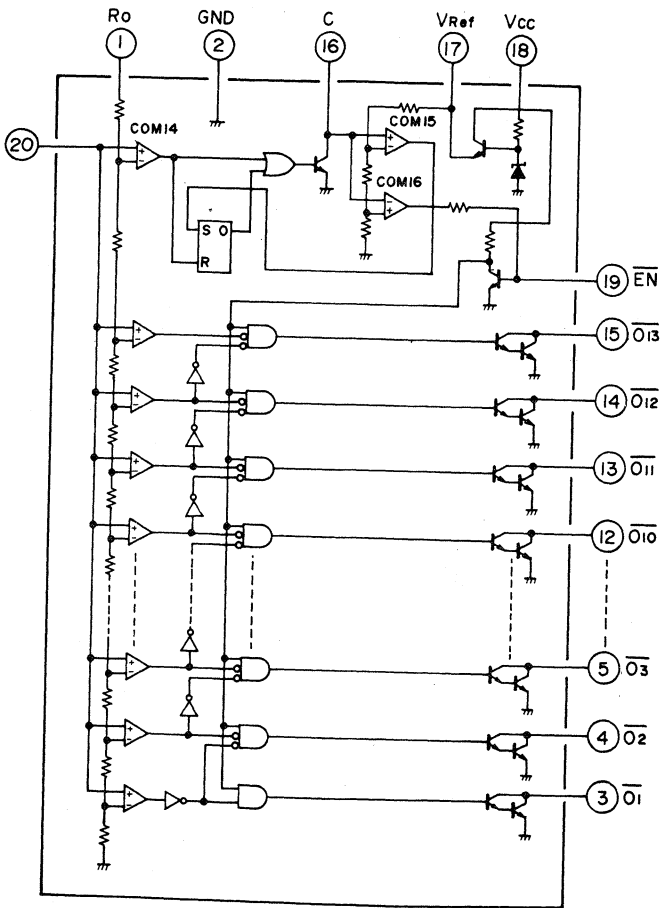

BA6251

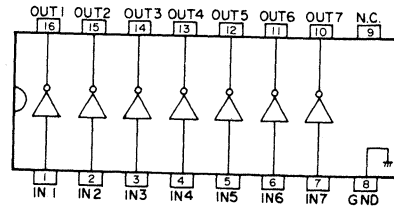

LA6358

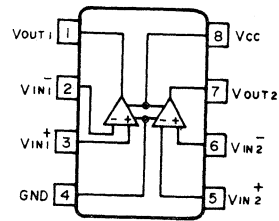

LM6405H-320

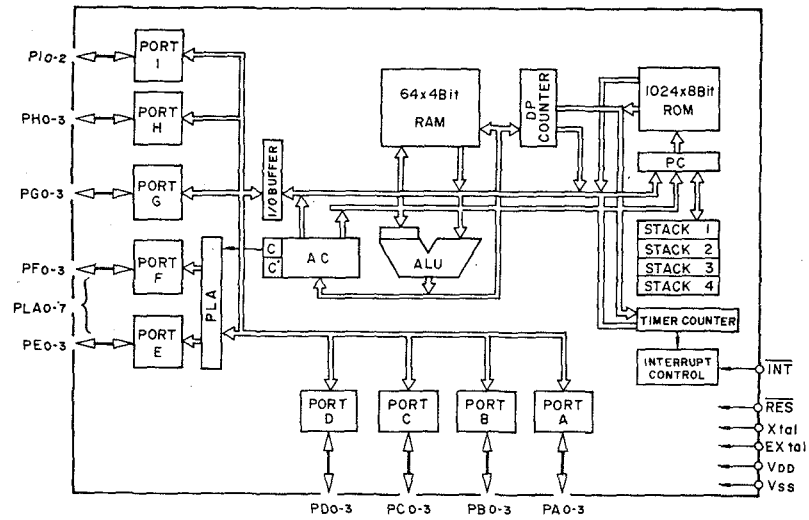

LC7800

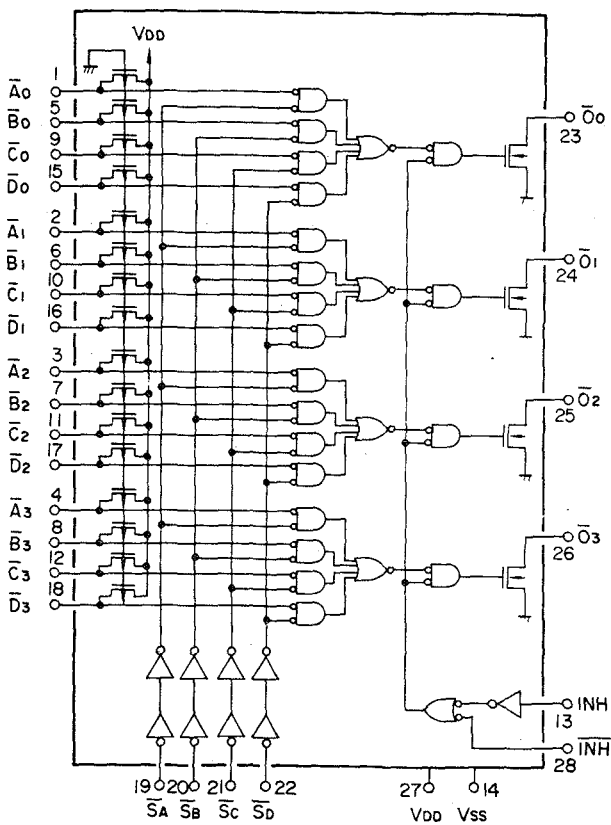

MC14584BCP

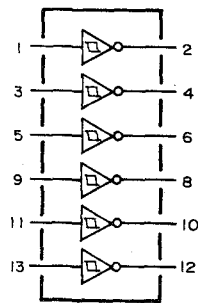

V_{DD} = Pin 14
V_{SS} = Pin 7

HD14013BP

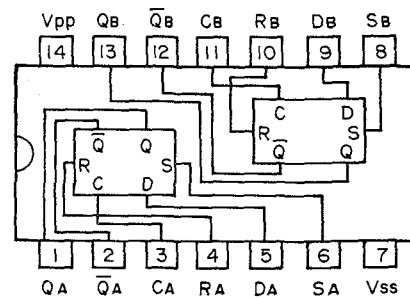

REF. NO.	PARTS NO.	DESCRIPTION	COMMON MODELS	REMARKS
1 - 1	5504744000	Table Assy, Reel	X-10R	
1 - 2	*5200136000	PCB Assy, COUNTER	X-2000R	
1 - 3	*5800553500	Chassis, Tape Counter	X-2000R	
1 - 4	5800285000	Cap Screw; S (X-2000)	X-2000R	
	5800323400	Cap Screw; B (X-2000B/X-2000M)	X-2000RB	
1 - 5	*5800622700	Housing Assy, Head; S (X-2000)		
	*5800622900	Housing Assy, Head; B (X-2000B)		
	*5800623100	Housing Assy, Head; M (X-2000M)		
1 - 6	5800549500	Roller Assy, Tension; S (X-2000)	X-2000R	
	5800549400	Roller Assy, Tension; B (X-2000B/X-2000M)	X-2000RB	
1 - 7	*5800544800	Housing Base; S (X-2000)	X-2000R	
	*5800544700	Housing Base; B (X-2000B/X-2000M)	X-2000RB	
1 - 8	5800549300	Cap, Pinch Roller; S (X-2000)	X-2000R	
	5800549200	Cap, Pinch Roller; B (X-2000B/X-2000M)	X-2000RB	
1 - 9	5014175100	Pinch Roller	X-2000R	
1 - 10	5800546600	Knob, Small-Size; S (X-2000)	X-2000R	
	5800546501	Knob, Small-Size; B (X-2000B/X-2000M)	X-2000RB	
1 - 11	*5800623300	Panel Assy, Control; S (X-2000)	X-2000R	
	*5800623500	Panel Assy, Control; B (X-2000B)	X-2000RB	
	*5800623700	Panel Assy, Control; M (X-2000M)		
1 - 12	*5200135910	PCB Assy, OPERATION		
1 - 13	*5800556100	Case; LB	X-2000R	
1 - 14	*5533190000	Foot [All except L]	X-10R	
1 - 15	*5800321602	Case Assy [L]	X-1000RB	
1 - 16	*5504499000	Screw, Case [L]	A-480	
1 - 30	*5780014008	Screw, Bind Head; M4 x 8 (Ni)		
1 - 31	*5780133006	Screw, Pan Head Sems A; M3 x 6		
1 - 32	*5780143006	Screw, Pan Head Sems B; M3 x 6		
1 - 33	*5781703010	Screw, Cap; M3 x 10 (Ni) (X-2000)	X-2000R	
	*5781713010	Screw, Cap; M3 x 10 (BLK Ni) (X-2000B/X-2000M)	X-2000RB	
1 - 34	*5781103000	Screw, Bind Tapping; M3 x 8		
1 - 35	*5783114006	Screw, Round Washer Head; M4 x 6 (BLK Ni) [All except L]		
1 - 36	*5780004020	Screw, Bind M4 x 20 [All except L]		
1 - 37	*5780204010	Screw, Flat Countersunk Head; M4 x 10 [L]		
1 - 38	*5781123010	Screw, Bind Tapping; M3 x 10		
1 - 39	*5785315000	Washer, Flat $\phi 5 \times \phi 8 \times t0.5$		

INCLUDED ACCESSORIES

REF. NO.	PARTS NO.	DESCRIPTION	COMMON MODELS	REMARKS
	*5062962000	Splicing Tape		
	*5350008500	Cord, Input-Output Connection		
	*5598054001	Reel Adapter, Clamp (TZ-612A)		
	*5700058000	Own's Manual, (X-2000M) [J]		
	*5700058100	Own's Manual, (X-2000/X-2000M) [All except J]		

Parts marked with *require longer delivery time.

[U]: U.S.A.
[E]: EUROPE

[C]: CANADA
[UK]: U.K.

[GE]: GENERAL EXPORT
[L]: LIMITED AREA

[A]: AUSTRALIA
[J]: JAPAN

EXPLODED VIEW-2

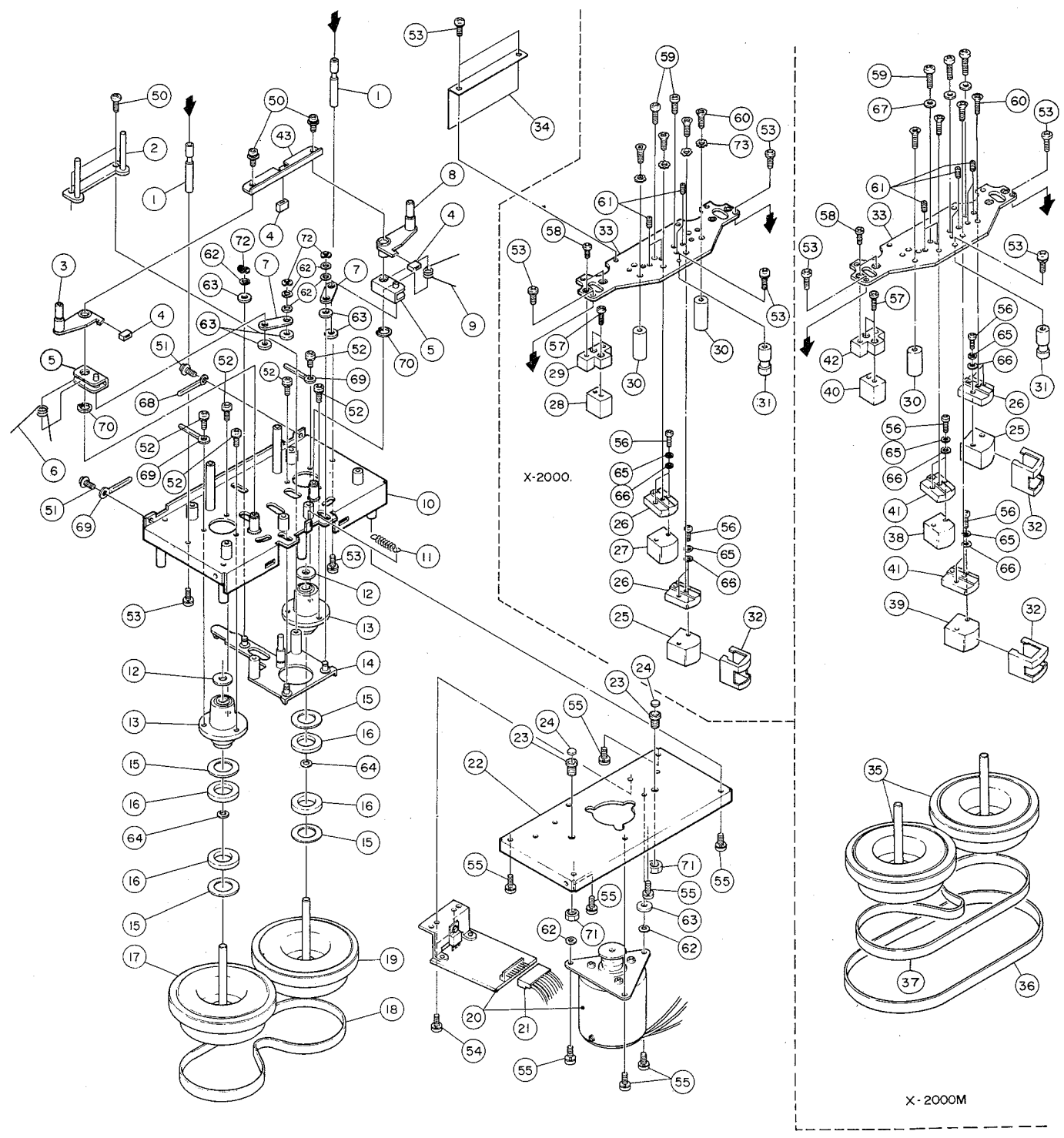

REF. NO.	PARTS NO.	DESCRIPTION	COMMON MODELS	REMARKS
2 - 1	*5545023001	Pin, Tape Guide		
2 - 2	*5800554200	Plate Assy, Lifter	X-10R X-2000R	
2 - 3	*5504730000	Arm Assy, Pinch Roller; L	X-10R	
2 - 4	*5534694000	Cushion, Stopper	X-10R	
2 - 5	*5504731000	Arm Assy, Pressure	X-10R	
2 - 6	*5524217000	Spring, Pinch Roller; L	X-10R	
2 - 7	*5555667000	Plate, Joint	X-10R	
2 - 8	*5504729000	Arm Assy, Pinch Roller; R	X-10R	
2 - 9	*5524216000	Spring, Pinch Roller; R	X-10R	
2 - 10	*5800527500	Base Assy, Capstan	X-1000R	
2 - 11	*5524219000	Spring, Slide Plate	X-10R	
2 - 12	*5534695000	Washer, Oil Retaining	X-10R	
2 - 13	5504726100	Housing Assy, Capstan Flywheel	X-10R	
2 - 14	*5800526400	Plate Assy, Slide	X-1000R	
2 - 15	*5555704000	Tape, Adhesive	X-10R	
2 - 16	5534715000	Magnet Ling, Thrust	X-10R	
2 - 17	5504728000	Flywheel Assy, Capstan; L (X-2000/X-2000B)	X-10R	
2 - 18	5534692001	Belt, Capstan (4T) (X-2000/X-2000B)	X-10R	
2 - 19	5504727000	Flywheel Assy, Capstan; R (X-2000/X-2000B)	X-10R	
2 - 20	7105018003	DC Motor Assy, Capstan (X-2000/X-2000B)	X-7R	
	7105021001	DC Motor Assy, Capstan (X-2000M)		
2 - 21	*5122172000	Connector Socket, 10P		
2 - 22	*5800138000	Plate, Capstan Motor	X-20R	
2 - 23	*5544003000	Screw, Thrust	A-7300	
2 - 24	*5555703000	Washer, Thrust	X-10R	
2 - 25	5378302900	Head, Playback; 4T-2ch		
2 - 26	*5800568401	Base, Head	X-2000R	
2 - 27	5378303000	Head, Record; 4T-2ch (X-2000/X-2000B)		
2 - 28	5378300800	Head, Erase; 4T (X-2000/X-2000B)	X-20R	
2 - 29	*5800285300	Spacer, Erase Head (X-2000/X-2000B)	X-1000R	
2 - 30	*5800622500	Head, Dummy (X-2000/X-2000B; 2 used)		
2 - 31	*5800554100	Guide, Tape	X-2000R	
2 - 32	*5800568600	Case, Shield	X-2000R	
2 - 33	*5800554000	Base, Head	X-2000R	
2 - 34	*5800566600	Shield Plate, Counter	X-2000R	
2 - 35	*5504749000	Flywheel Assy, Capstan (X-2000M)	X-10R	
2 - 36	5534690000	Belt, Capstan; 2T (X-2000M)	X-10M	
2 - 37	5534693000	Belt, Capstan (X-2000M)	X-10R	
2 - 38	5378303100	Head, Record; 2T-2ch (X-2000M)		
2 - 39	5378303200	Head, Playback; 2T-2ch (X-2000M)		
2 - 40	5378301100	Head, Erase; 2T-2ch (X-2000M)		
2 - 41	*5800622400	Base, Head; 2T (X-2000M)		
2 - 42	*5800285300	Spacer, Erase Head (X-2000M)		
2 - 43	*5555666000	Plate, Reinforcement		
2 - 50	*5780143006	Screw, Pan Head Sems B; M3 x 6		
2 - 51	*5780143008	Screw, Pan Head Sems B; M3 x 8		
2 - 52	*5780134010	Screw, Pan Head Sems A; M4 x 10		
2 - 53	*5780133008	Screw, Pan Head Sems A; M3 x 8		
2 - 54	*5780103006	Screw, Pan Head; M3 x 6		
2 - 55	*5780134008	Screw, Pan Head Sems A; M4 x 8		
2 - 56	*5780012006	Screw, Bind Head; M2 x 6 (Ni)		
2 - 57	*5782802008	Screw, B Tite; M2 x 8		
2 - 58	*5783013008	Screw, Pan Head B Tite; M3 x 8		
2 - 59	*5780003008	Screw, Bind Head; M3 x 8		
2 - 60	*5780203008	Screw, Flat Countersunk; M3 x 8		
2 - 61	*5782003006	Set Screw, Hex Socket (Flat Point); M3 x 6		
2 - 62	*5785004000	Washer, (X-2000/X-2000B)		
2 - 63	*5785024200	Washer, Flat $\phi 4 \times \phi 12 \times t0.8$ (X-2000/X-2000B)		
2 - 64	*5785316000	Washer, Flat $\phi 6 \times \phi 9.5 \times t0.5$		
2 - 65	*5785002000	Washer, Flat		
2 - 66	*5785102000	Washer, Spring $\phi 2$		
2 - 67	*5785013000	Washer, Flat		
2 - 68	*5786713000	Clamper, Cord $\phi 3$		
2 - 69	*5786714000	Clamper, Cord $\phi 4$		
2 - 70	*5786118000	Ring, E Type $\phi 8$		
2 - 71	*5781836000	Nut, Type 3; M3		
2 - 72	*5786003000	Ring, E Type $\phi 3$		
2 - 73	*5785123000	Washer, Lock $\phi 3$		

Parts marked with *require longer delivery time.

[U]: U.S.A.
[E]: EUROPE

[C]: CANADA
[UK]: U.K.

[GE]: GENERAL EXPORT
[L]: LIMITED AREA

[A]: AUSTRALIA
[J]: JAPAN

EXPLODED VIEW-3

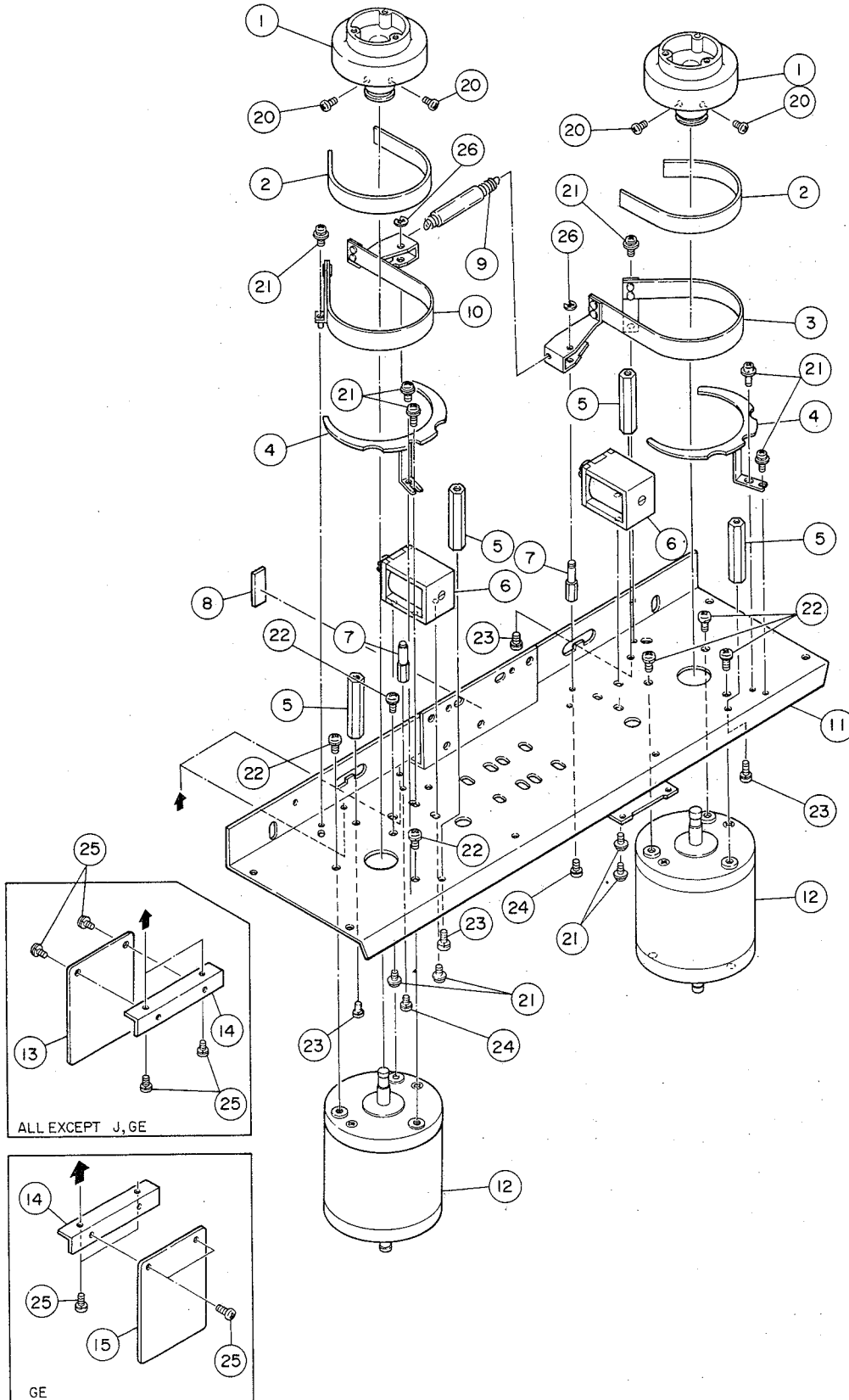

REF. NO.	PARTS NO.	DESCRIPTION	COMMON MODELS	REMARKS
3 - 1	5800346200	Base, Reel Table; B	X-1000R	
3 - 2	5555274000	Felt, Brake	A-3300SX	
3 - 3	5504736000	Band Assy, Brake; R	X-10R	
3 - 4	*5555685000	Plate, Band	X-10R	
3 - 5	*5544916000	Stay, Top Panel; A	A-6100MKII	
3 - 6	5163044000	Solenoid, Brake		
3 - 7	*5545033000	Shaft, Brake	X-10R	
3 - 8	*5555570000	Cushion, B		
3 - 9	*5524294000	Spring, Brake	X-10R	
3 - 10	5504735000	Band Assy, Brake; L	X-10R	
3 - 11	*5503194002	Chassis Assy, Reel	X-10R	
3 - 12	5370004800	DC Motor, Reel	X-2000R	
3 - 13	*5200140401	PCB Assy, FUSE; 1 [E, UK, A]		
	*5200140501	PCB Assy, FUSE; 2 [U, C]		
3 - 14	*5555789000	Bracket, FUSE PCB	X-10R	
3 - 15	*5200140600	PCB Assy, VOLTAGE SELECTOR [GE, L]		
3 - 20	*5783564008	Screw, Pan Head Sems C; M4 x 8		
3 - 21	*5780143006	Screw, Pan Head Sems B; M3 x 6		
3 - 22	*5783564010	Screw, Pan Head Sems C; M4 x 10		
3 - 23	*5780134008	Screw, Pan Head Sems A; M4 x 8		
3 - 24	*5780133008	Screw, Pan Head Sems A; M3 x 8		
3 - 25	*5780133006	Screw, Pan Head Sems A; M3 x 6		
3 - 26	*5786003000	Ring, E Type; $\phi 3$		

Parts marked with *require longer delivery time. [U]: U.S.A. [C]: CANADA [GE]: GENERAL EXPORT [A]: AUSTRALIA
 [E]: EUROPE [UK]: U.K. [L]: LIMITED AREA [J]: JAPAN

(Continued from page 41)

REF. NO.	PARTS NO.	DESCRIPTION	COMMON MODELS	REMARKS
6 - 50	*5780103006	Screw, Pan Head; M3 x 6		
6 - 51	*5780163006	Screw, Pan Head Sems C; M3 x 6		
6 - 52	*5780013006	Screw, Bind Head; M3 x 6 (Ni)		
6 - 53	*5780133006	Screw, Pan Head Sems A; M3 x 6		
6 - 54	*5780203006	Screw, Flat Head M3 x 6		
6 - 55	*5780102604	Screw, Pan Head M2.6 x 4		
6 - 56	*5786360500	Pin, R Type; $\phi 5$		
6 - 57	*5780012604	Screw, Bind Head; M2.6 x 4 (Ni)		

Parts marked with *require longer delivery time. [U]: U.S.A. [C]: CANADA [GE]: GENERAL EXPORT [A]: AUSTRALIA
 [E]: EUROPE [UK]: U.K. [L]: LIMITED AREA [J]: JAPAN

EXPLODED VIEW-4

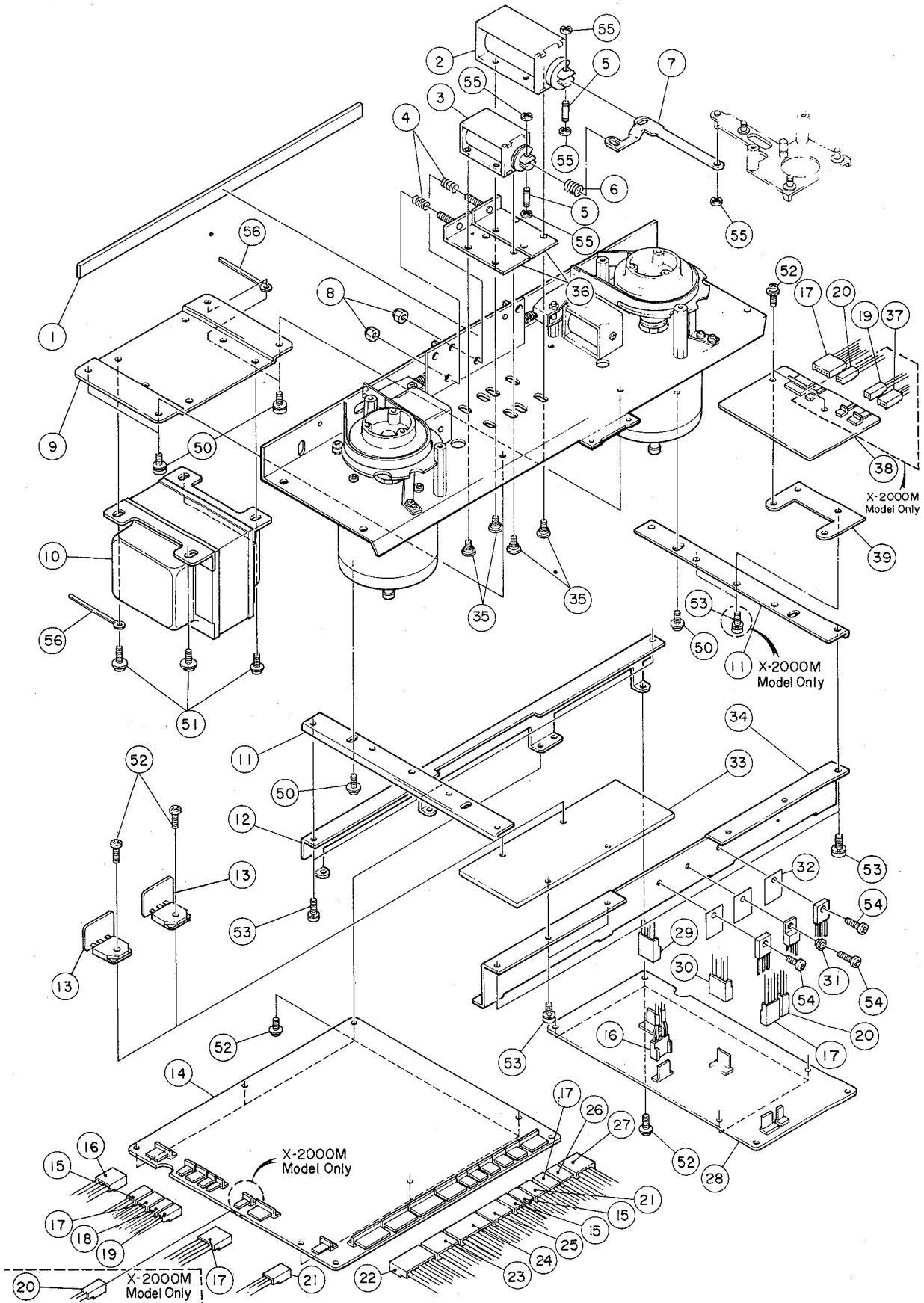

REF. NO.	PARTS NO.	DESCRIPTION	COMMON MODELS	REMARKS
4 - 1	*555887001	Cushion, Case	X-10R	
4 - 2	5163041001	Solenoid, Pinch Roller		
4 - 3	5163042000	Solenoid, Pause		
4 - 4	*5524218000	Spring, Pressure Regulation	X-10R	
4 - 5	*5545022000	Pin, Solenoid	X-10R	
4 - 6	*5524071000	Spring, Solenoid	AL-700	
4 - 7	*5555668000	Plate, C	X-10R	
4 - 8	*5581066000	Nut, Nylon; M4		
4 - 9	*5555681101	Bracket, Power Transformer		
4 - 10	△ 5320027300	Transformer, AC Power [J]		
	△ 5320027400	Transformer, AC Power [U]		
	△ 5320027500	Transformer, AC Power [GE, L]		
	△ 5320027600	Transformer, AC Power [E, UK, A]		
	△ 5320034100	Transformer, AC Power [C]		
4 - 11	*5553296001	Frame, Joint	X-10R	
4 - 12	*5800553200	Frame, PCB	X-2000R	
4 - 13	*5200073100	PCB Assy, TRANSISTOR		
4 - 14	*5200135410	PCB Assy, POWER SERVO (X-2000/X-2000B)		
	*5200135420	PCB Assy, POWER SERVO (X-2000M)		
4 - 15	*5122222000	Connector Socket, 3P (BLK)		
4 - 16	*5122167000	Connector Socket, 5P (WHT)		
4 - 17	*5122166000	Connector Socket, 4P (WHT)		
4 - 18	*5122221000	Connector Socket, 2P (BLK)		
4 - 19	*5122280000	Connector Socket, 2P (RED)		
4 - 20	*5122164000	Connector Socket, 2P (WHT)		
4 - 21	*5122281000	Connector Socket, 3P (RED)		
4 - 22	*5122172000	Connector Socket, 10P (WHT)		
4 - 23	*5122227000	Connector Socket, 8P (BLK)		
4 - 24	*5122176000	Connector Socket, 14P (WHT)		
4 - 25	*5122287000	Connector Socket, 9P (RED)		
4 - 26	*5122223000	Connector Socket, 4P (BLK)		
4 - 27	*5122168000	Connector Socket, 6P (WHT)		
4 - 28	*5200135600	PCB Assy, DBX		
4 - 29	*5122283000	Connector Socket, 5P (RED)		
4 - 30	*5122282000	Connector Socket, 4P (RED)		
4 - 31	*5033295000	Tube, Insulating		
4 - 32	*5033291000	Plate, Insulating		
4 - 33	*5800553800	Heatsink	X-2000R	
4 - 34	*5800553300	Frame, HS	X-2000R	
4 - 35	*5800022600	Screw, Shoulder; G	X-10R	
4 - 36	*5504732000	Plate Assy, Solenoid		
4 - 37	*5122165000	Connector Socket, 3P (WHT)		
4 - 38	*5200154311	PCB Assy, SPOOLING (X-2000M)		
	*5200154301	PCB Assy, SPOOLING (X-2000/X-2000B)		
4 - 39	*5800525400	Plate, PCB	X-700R	
4 - 50	*5780134008	Screw, Pan Head Sems A; M4 x 8		
4 - 51	*5780144008	Screw, Pan Head Sems B; M4 x 8		
4 - 52	*5780143006	Screw, Pan Head Sems B; M3 x 6		
4 - 53	*5780133006	Screw, Pan Head Sems A; M3 x 6		
4 - 54	*5780003008	Screw, Bind; M3 x 8		
4 - 55	*5786003000	Ring, E Type; φ3		
4 - 56	*5786714000	Clamper, Cord; φ4		

Parts marked with *require longer delivery time.

[U]: U.S.A.
[E]: EUROPE

[C]: CANADA
[UK]: U.K.

[GE]: GENERAL EXPORT
[L]: LIMITED AREA

[A]: AUSTRALIA
[J]: JAPAN

EXPLODED VIEW-5

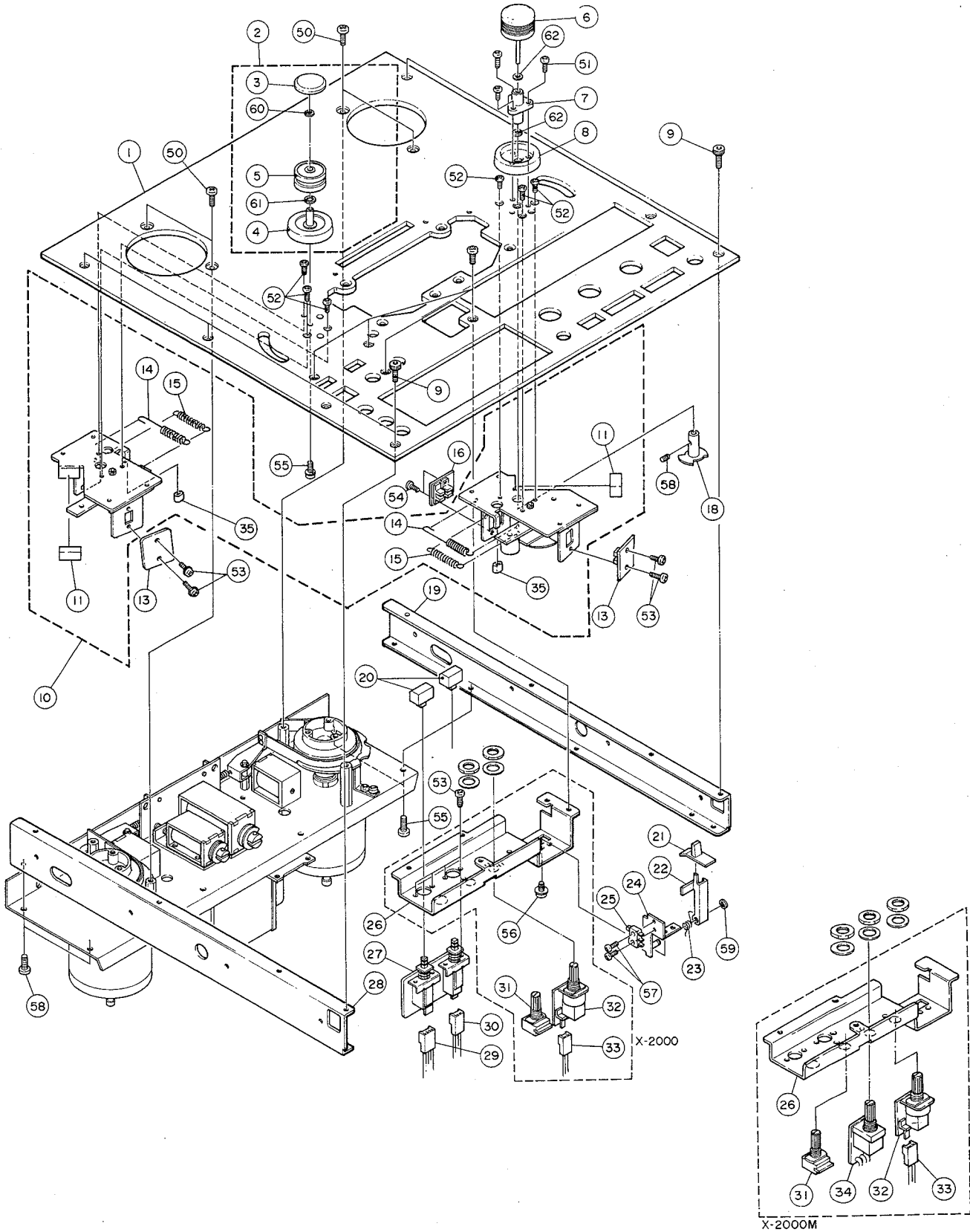

REF. NO.	PARTS NO.	DESCRIPTION	COMMON MODELS	REMARKS
5 - 1	*5800543700	Panel, Deck; S (X-2000)	X-2000R	
	*5800543600	Panel, Deck; B (X-2000B/X-2000M)	X-2000RB	
5 - 2	*5800621800	Roller Assy; S (X-2000)		
	*5800622100	Roller Assy; B (X-2000B/X-2000M)		
5 - 3	*5800551100	Cap, Roller; S (X-2000)	X-2000R	
	5800551000	Cap, Roller; B (X-2000B/X-2000M)	X-2000RB	
5 - 4	*5800621900	Base Assy, Roller; S (X-2000)		
	*5800622200	Base Assy, Roller; B (X-2000B/X-2000M)		
5 - 5	*5504743004	Roller Assy, B	X-10R	
5 - 6	5800550300	F Roller Assy, S (X-2000)	X-2000R	
	5800550200	F Roller Assy, B (X-2000B/X-2000M)	X-2000RB	
5 - 7	*5504516000	Holder Assy, Metal		
5 - 8	*5800550700	Base, F Roller; S (X-2000)	X-2000R	
	*5800550600	Base, F Roller; B (X-2000B/X-2000M)		
5 - 9	*5800553700	Screw, Cap; B (X-2000)		
	*5800553600	Screw, Cap; B (X-2000B/X-2000M)		
5 - 10	5772912000	Tention Arm Assy; L, R		
5 - 11	*5534686001	Cushion	X-10R	
5 - 12		Not used		
5 - 13	*5200067402	PCB Assy, TENSION SENSOR	X-1000R	
5 - 14	*5800676100	Spring, TA		
5 - 15	*5800270801	Spring, Return	X-1000R	
5 - 16	*5200136100	PCB Assy, ROLLER SENSOR		
5 - 17		Not used		
5 - 18	*5800271302	Plate Assy, Reflector	X-1000R	
5 - 19	*5800553000	Angle, Side; R	X-2000R	
5 - 20	5800546800	Button, T/S; S (X-2000)	X-2000R	
	5800546701	Button, T/S; B (X-2000B/X-2000M)	X-2000RB	
5 - 21	5800546400	Knob, CUE; S (X-2000)	X-2000R	
	5800546301	Knob, CUE; B (X-2000B/X-2000M)	X-2000RB	
5 - 22	*5800401000	Lever, CUE; B	X-1000R	
5 - 23	*5524223001	Spring, CUE	X-10R	
5 - 24	*5504737000	Bracket Assy, CUE	X-10R	
5 - 25	5301455500	Switch, Micro; SS5GL13-F		
5 - 26	*5800553400	Chassis, Switch	X-2000R	
5 - 27	*5200136200	PCB Assy, SPEED SWITCH (X-2000/X-2000B)		
	*5200154600	PCB Assy, SPEED SWITCH (X-2000M)		
5 - 28	*5800553100	Angle, Side; L	X-2000R	
5 - 29	*5122281000	Connector Socket, 3P (RED)		
5 - 30	*5122166000	Connector Socket, 4P (WHT)		
5 - 31	*5282250600	Variable Resistor, 100kΩ (B)		
5 - 32	*5200154400	PCB Assy, PICHCON.		
5 - 33	*5122164000	Connector Socket, 2P (WHT)		
5 - 34	*5200154500	PCB Assy, HEAD SWITCH (X-2000M)		
5 - 35	*5027699000	Collar, Rubber		
5 - 50	*5780204010	Screw, Flat Countersunk Head, M4 x 10		
5 - 51	*5780163006	Screw, Pan Head Sems C, M3 x 6		
5 - 52	*5780203008	Screw, Flat Countersunk Head, M3 x 8		
5 - 53	*5780003008	Screw, Bind Head; M3 x 8		
5 - 54	*5780133006	Screw, Pan Head Sems A, M3 x 6		
5 - 55	*5780134008	Screw, Bind Head, M4 x 8 (Ni)		
5 - 56	*5780143006	Screw, Pan Head Sems B, M3 x 6		
5 - 57	*5780102010	Screw, Pan Head, M2 x 10		
5 - 58	*5782213303	Setscrew, Hex Socket (Cup Point), M3 x 3		
5 - 59	*5786003000	Ring, E Type, φ3		
5 - 60	*5785305000	Washer, Flat; φ5 x φ8 x t0.25		
5 - 61	*5785315000	Washer, Flat; φ5 x φ8 x t0.5		
5 - 62	*5785003000	Washer, Flat; M3 Type t0.5		

Parts marked with *require longer delivery time.

[U]: U.S.A.
[E]: EUROPE

[C]: CANADA
[UK]: U.K.

[GE]: GENERAL EXPORT
[L]: LIMITED AREA

[A]: AUSTRALIA
[J]: JAPAN

EXPLODED VIEW-6

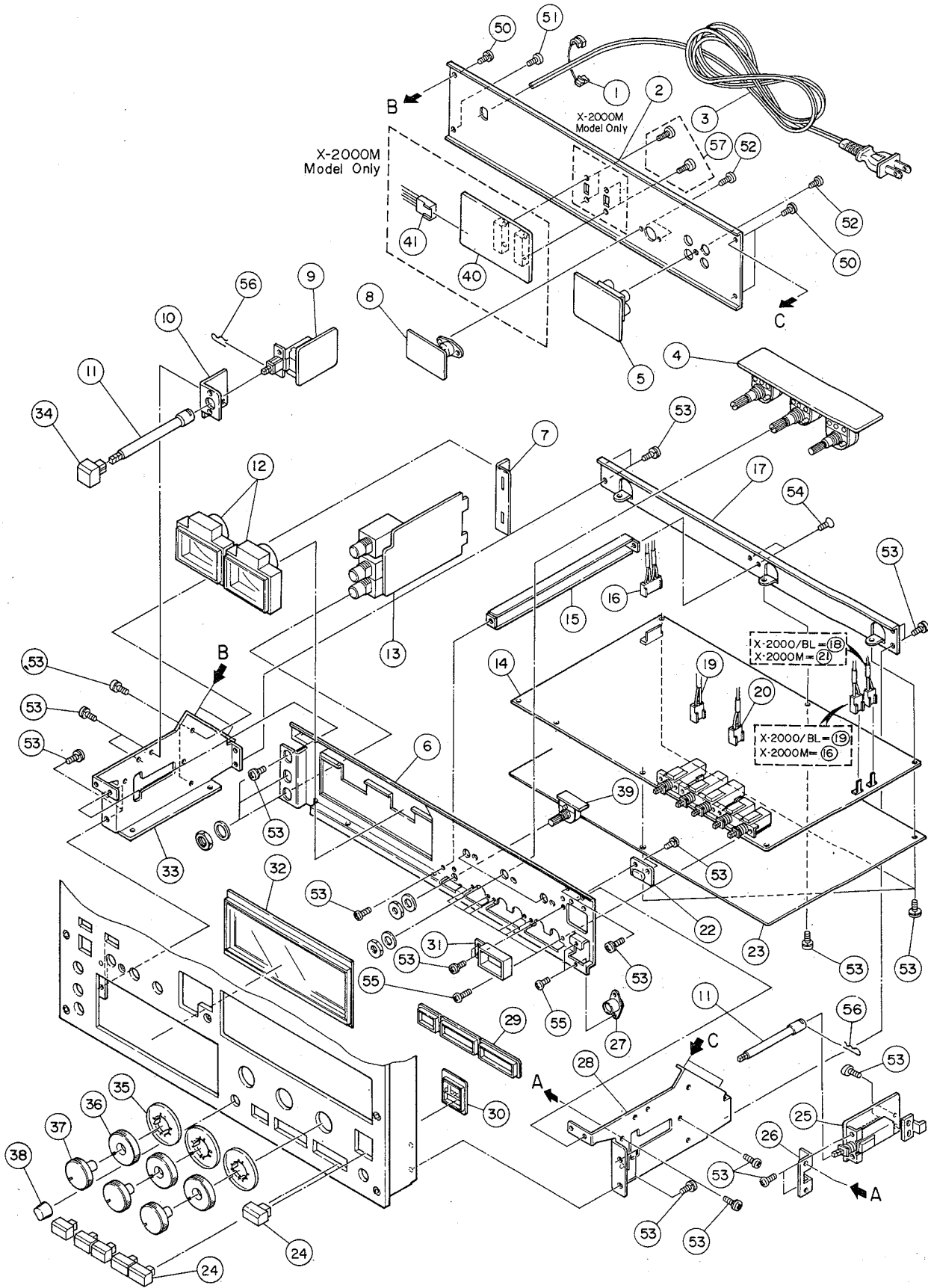

REF. NO.	PARTS NO.	DESCRIPTION	COMMON MODELS	REMARKS
6 - 1	△*5534660000	Strain Relief, AC Power Cord [All except UK]		
	△*5317001700	Strain Relief, AC Power Cord [UK]		
6 - 2	*5800552800	Panel, Rear (X-2000/X-2000B)	X-2000R	
	*5800622600	Panel, Rear (X-2000M)		
6 - 3	△*5350010800	Cord, AC Power [U, C, GE, L]		
	△*5350008200	Cord, AC Power [E]		
	△*5128047000	Cord, AC Power [UK]		
	△*5128027000	Cord, AC Power [J]		
	△*5350008300	Cord, AC Power [A]		
6 - 4	*5200135800	PCB Assy, VR	X-2000R	
6 - 5	*5200136400	PCB Assy, IN/OUTPUT	X-2000R	
6 - 6	*5800551800	Chassis Assy, Ampl.	X-2000R	
6 - 7	*5800552400	Angle, PCB	X-2000R	
6 - 8	*5200142310	PCB Assy, DUPLI SYNC		
6 - 9	*5200113100	PCB Assy, POWER SWITCH [J, GE, L]	X-1000R	
	*5200113110	PCB Assy, POWER SWITCH [U]	X-1000R	
	*5200141901	PCB Assy, POWER SWITCH [E, UK, A]	X-2000R	
	*5200113120	PCB Assy, POWER SWITCH [C]	X-1000R	
6 - 10	*5800552500	Bracket, Power Switch	X-2000R	
6 - 11	*5534712000	Rod, B	X-10R	
6 - 12	5296006800	Meter, VU (X-2000)	X-2000R	
	5296006900	Meter, VU (X-2000B/X-2000M)	X-2000RB	
6 - 13	*5200135700	PCB Assy, HEAD PHONE	X-2000R	
6 - 14	*5200154700	PCB Assy, REC/PLAY AMPL.; 2 (X-2000/X-2000B)		
	*5200154100	PCB Assy, REC/PLAY AMPL.; 3 (X-2000M)	X-2000R	
6 - 15	*5800552600	Angle, PCB	X-2000R	
6 - 16	*5122166000	Connector Socket, 4P (WHT)		
6 - 17	*5800552700	Flam, Ampl., Back	X-2000R	
6 - 18	*5122280000	Connector Socket, 2P (RED)		
6 - 19	*5122164000	Connector Socket, 2P (WHT)		
6 - 20	*5122221000	Connector Socket, 2P (BLK)		
6 - 21	*5122282000	Connector Socket, 4P (RED)		
6 - 22	*5200136600	PCB Assy, DBX LAMP	X-2000R	
6 - 23	*5800552900	Plate, Shield	X-2000R	
6 - 24	5800547800	Button, Ampl.; S (X-2000)	X-2000R	
	5800547701	Button, Ampl.; B (X-2000B/X-2000M)	X-2000RB	
6 - 25	*5200136700	PCB Assy, DBX SWITCH	X-2000R	
6 - 26	*5800552300	Bracket, Switch	X-2000R	
6 - 27	*5334027500	Connector Socket, 4P		
6 - 28	*5800552201	Frame, Ampl.; R	X-2000R	
6 - 29	*5800548500	Escutcheon, Button; S (X-2000)	X-2000R	
	*5800548400	Escutcheon, Button; B (X-2000B/X-2000M)	X-2000RB	
6 - 30	*5800547200	Lenz Assy, DBX, S (X-2000)	X-2000R	
	*5800547100	Lenz Assy, DBX; B (X-2000B/X-2000M)	X-2000RB	
6 - 31	*5800556400	Food, Lamp		
6 - 32	*5800548700	Escutcheon Assy, Meter; S (X-2000)	X-2000R	
	*5800548600	Escutcheon Assy, Meter; B (X-2000B/X-2000M)	X-2000RB	
6 - 33	*5800552101	Frame, Ampl.; L	X-2000R	
6 - 34	5800547000	Button, Power.; S (X-2000)	X-2000R	
	5800546901	Button, Power; B (X-2000B/X-2000M)	X-2000RB	
6 - 35	5800548300	Knob, Maker	X-2000R	
6 - 36	5800548200	Knob, Lower; S (X-2000)	X-2000R	
	5800548100	Knob, Lower; B (X-2000B/X-2000M)	X-2000RB	
6 - 37	5800548000	Knob, Upper; S (X-2000)	X-2000R	
	5800547900	Knob, Upper; B (X-2000B/X-2000M)	X-2000RB	
6 - 38	5800546600	Knob, Small; S (X-2000)	X-2000R	
	5800546501	Knob, Small; B (X-2000B/X-2000M)	X-2000RB	
6 - 39	*5200136500	PCB Assy, BIAS VR	X-2000R	
6 - 40	*5200154200	PCB Assy, NAB/IEC (X-2000M ONLY)		
6 - 41	*5122223000	Connector Socket, 4P (BLK)		

(Continued on page 35)

Parts marked with *require longer delivery time.

[U]: U.S.A.

[C]: CANADA

[GE]: GENERAL EXPORT

[A]: AUSTRALIA

[E]: EUROPE

[UK]: U.K.

[L]: LIMITED AREA

[J]: JAPAN

5 PC BOARD AND PARTS LIST

基板図とパーツ・リスト

VOLUME PCB ASSY

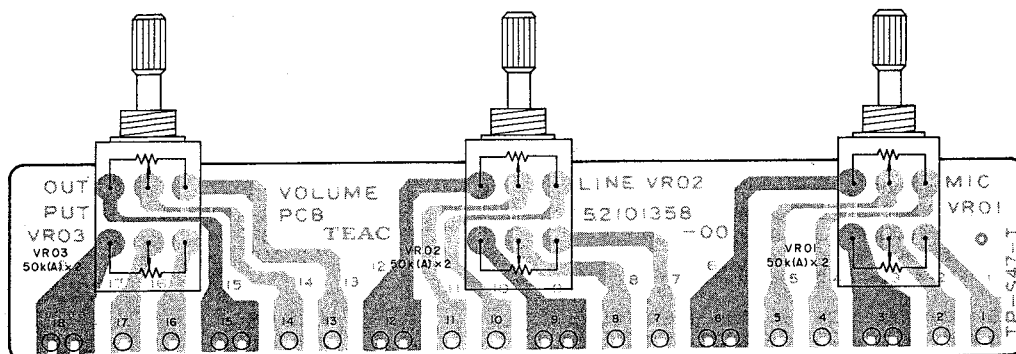

COUNTER PCB ASSY

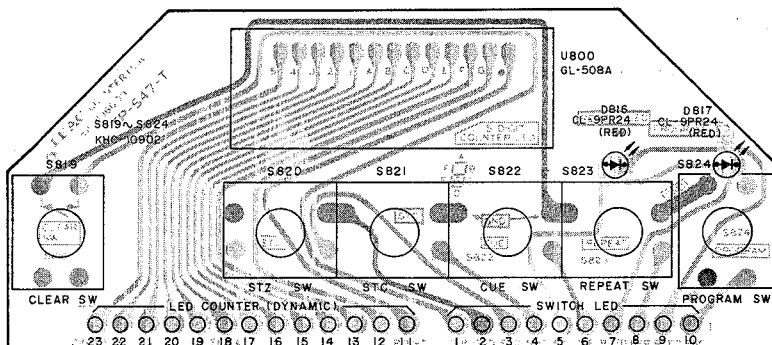

REC/PLAY AMPL. PCB ASSY(X-2000M)

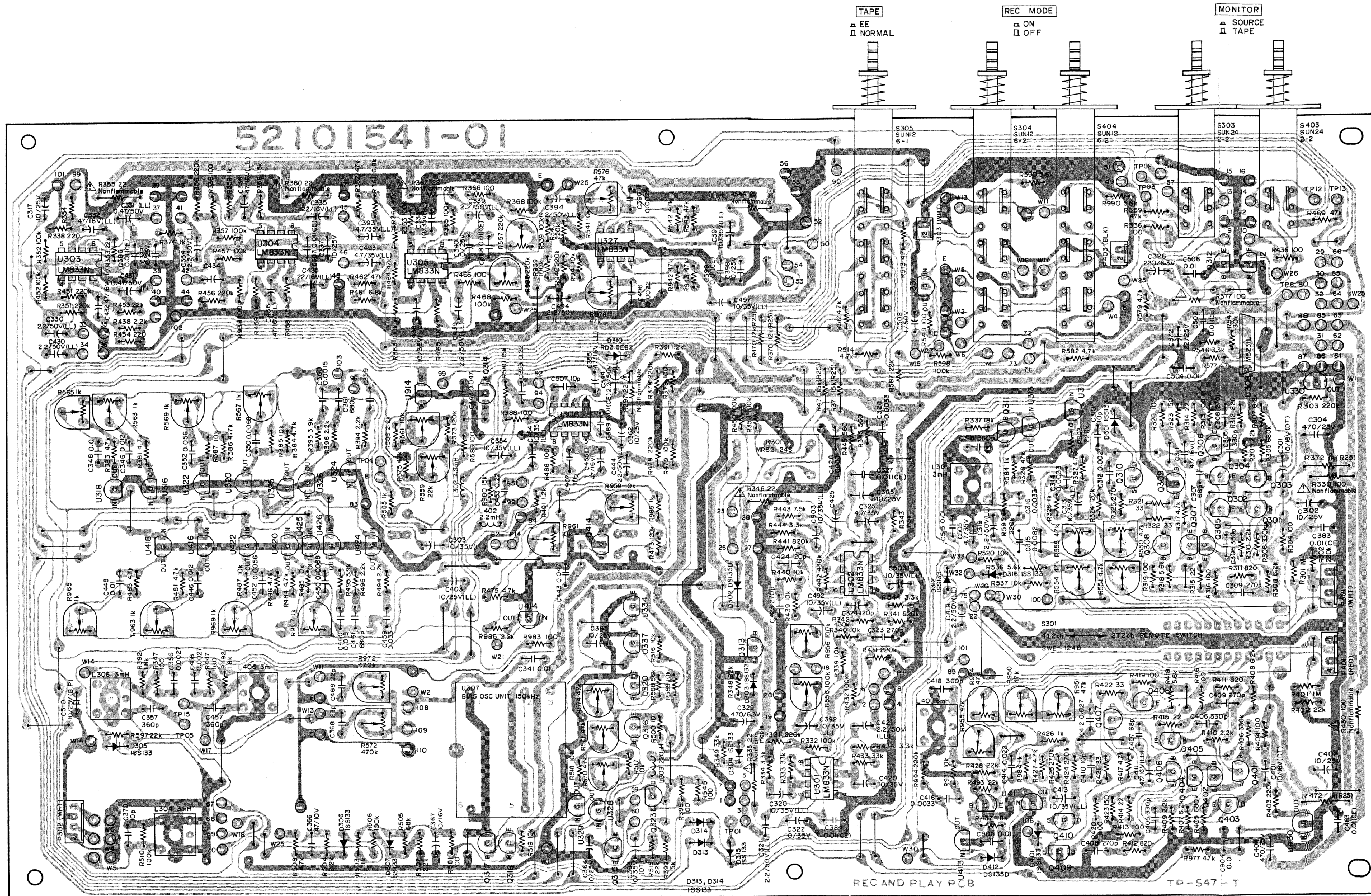

DBX PCB ASSY

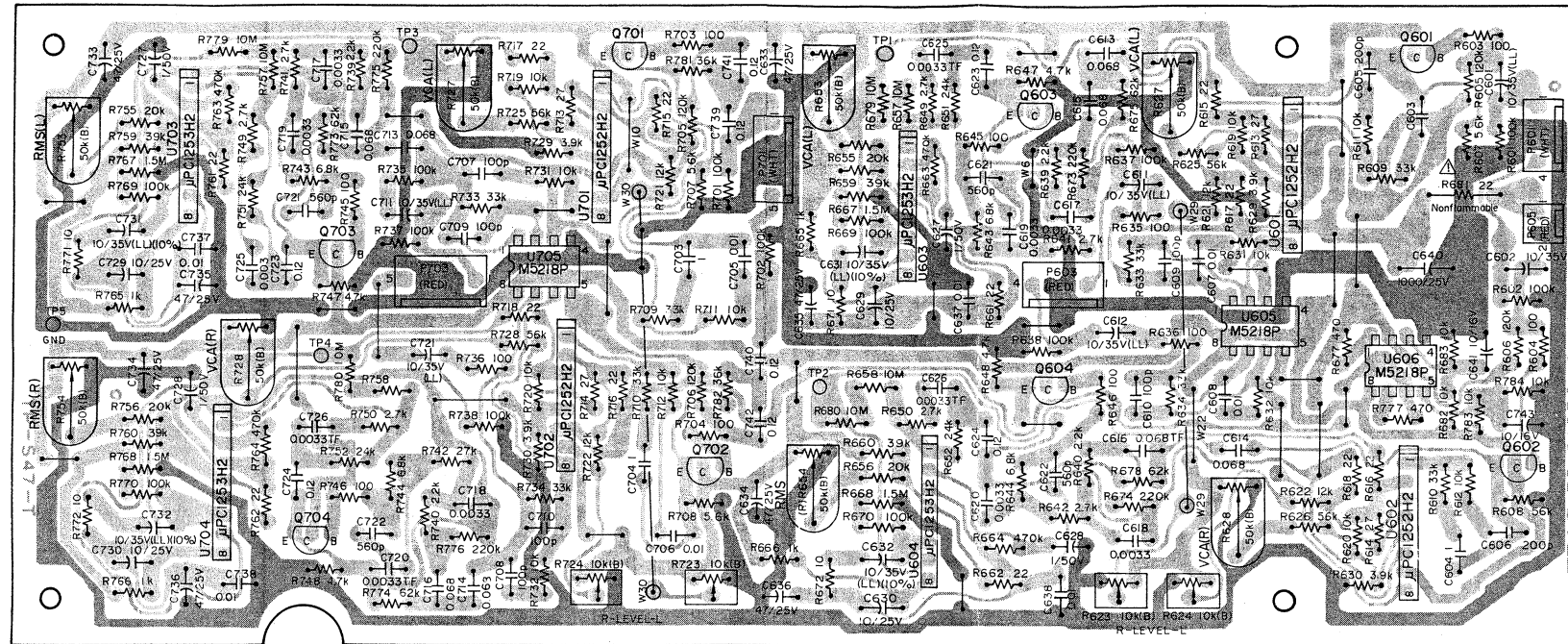

HEADPHONE PCB ASSY

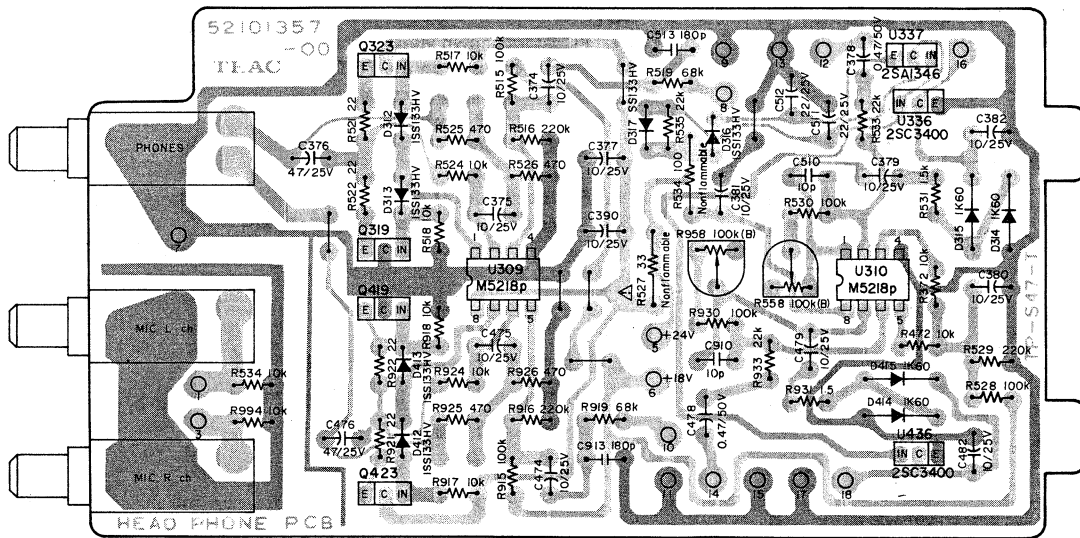

OPERATION PCB ASSY

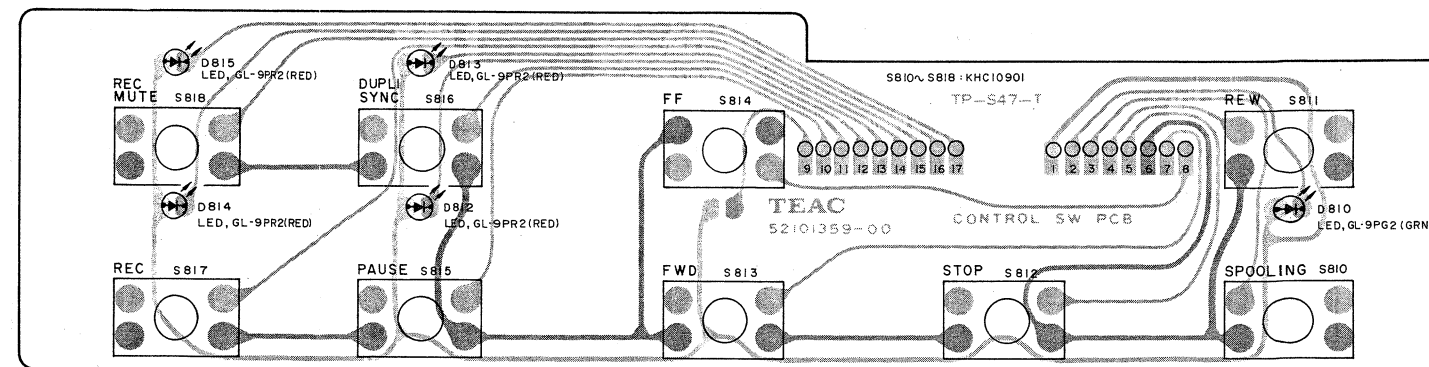

SPOOLING PCB ASSY

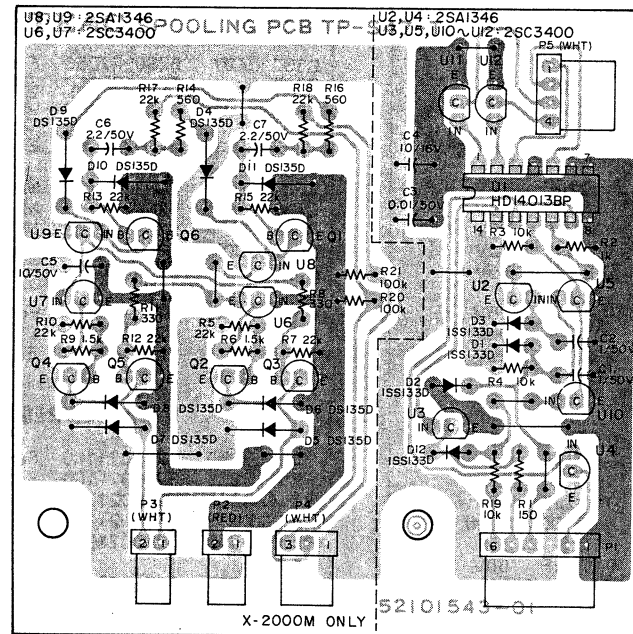

NAB/IEC PCB ASSY (X-2000M)

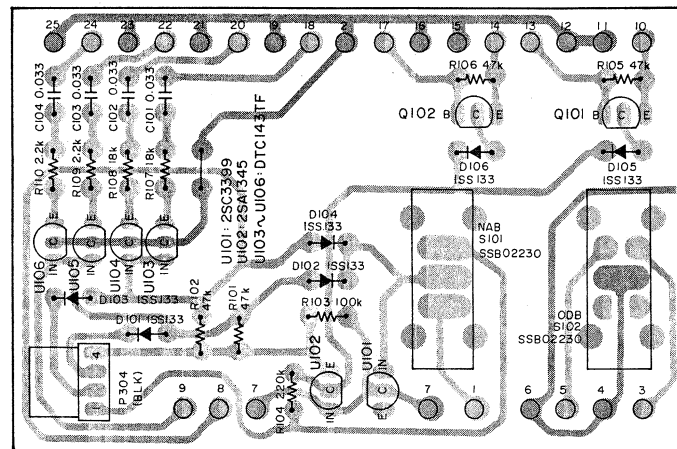

DUPLI SYNC PCB ASSY

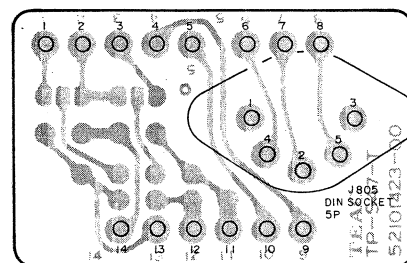

REC/PLAY AMPL. PCB ASSY

REF. NO.	PARTS NO.	DESCRIPTION
	*5200154700	PCB Assy; 2 (X-2000)
	*5200154100	PCB Assy; 3 (X-2000M)
	*5210154700	PCB (X-2000)
	*5210154100	PCB (X-2000M)
IC's		
U301~U306	5220420800	LM833N
U308	5220418300	M5231L
U327	5220420800	LM833N
TRANSISTORS		
Q301, Q401	5145036000	2SC945L-K
Q302, Q402	5145036000	2SC945L-K
Q303, Q403	5230018700	2SA733A-KB
Q304, Q404	5230018700	2SA733A-KB
Q305, Q405	5230016600	2SA999F
Q306, Q406	5230778300	2SC2320F
Q307, Q407	5230778300	2SC2320F
Q308, Q408	5230778300	2SC2320F
Q309, Q409	5230016600	2SA999F
Q310, Q410	5232007200	FET, 2SK364 BL
Q311, Q411	5145185000	2SD655E (X-2000M)
Q312, Q412	5145185000	2SD655E
Q313	5230778300	2SC2320F
Q314, Q414	5145185000	2SD655F
Q315	5230016600	2SA999F
Q316	5231758500	2SD1140
Q317	5145185000	2SD655E
Q318	5230778300	2SC2320F
Q320	5230778300	2SC2320F
Q323	5230016600	2SA999F
U311, U411	5232251400	DTC143TF, Digital
U312, U412	5232251400	DTC143TF, Digital (X-2000)
U313, U413	5232251400	DTC143TF, Digital
U314, U414	5232251400	DTC143TF, Digital
U315, U415	5232251400	DTC143TF, Digital
U316, U416	5232251400	DTC143TF, Digital
U317, U417	5232251400	DTC143TF, Digital
U318, U418	5232251400	DTC143TF, Digital
U320, U420	5232251400	DTC143TF, Digital
U322, U422	5232251400	DTC143TF, Digital
U324, U424	5232251400	DTC143TF, Digital
U325, U425	5232251400	DTC143TF, Digital
U326, U426	5232251400	DTC143TF, Digital
U328, U329	5232251400	DTC143TF, Digital
U330, R430	5232251400	DTC143TF, Digital
U331	5232252020	2SC3400, Digital
U334	5232251400	DTC143TF, Digital (X-2000M)
U337	5232251400	DTC143TF, Digital
DIODES		
D301, D401	5224015020	1SS133T-77
D302~D307	5224013210	DS135D-FA4
D310	5224539301	Zener, RD3.6EB2
D312, D412	5224013210	DS135D-FA4 (X-2000M)
D313~D317	5224015020	1SS133F77 (X-2000M)

REF. NO.	PARTS NO.	DESCRIPTION
CARBON RESISTORS		
All resistors are rated $\pm 5\%$ tolerance and $\frac{1}{4}W$.		
R301, R401	5240035420	1M Ω
R302, R402	5240033820	220k Ω (X-2000M)
R303, R403	5240033820	220k Ω
R304, R404	5240025820	100 Ω
R305, R405	5240035020	680k Ω
R306, R406	5240034220	330k Ω
R307, R407	5240030120	6.2k Ω
R308, R408	5240030120	6.2k Ω
R309, R409	5240029020	2.2k Ω
R310, R410	5240029020	2.2k Ω
R311, R411	5240028020	820 Ω
R312, R412	5240028020	820 Ω
R313, R413	5240025820	100 Ω
R314, R414	5240024220	22 Ω
R315, R415	5240024220	22 Ω
R316, R416	5240025820	100 Ω
R317, R417	5240029820	4.7k Ω
R318, R418	5240030020	5.6k Ω
R319, R419	5240025820	100 Ω
R320, R420	5240025820	100 Ω
R321, R421	5240024620	33 Ω
R322, R422	5240024620	33 Ω
R323, R423	5240026220	150 Ω
R324, R424	5240033220	120k Ω (X-2000)
	5240034020	270k Ω
R325, R425	5240034020	270k Ω
R326, R426	5240028220	1k Ω
R327, R427	5240029820	4.7k Ω
R328, R428	5240032220	47k Ω (X-2000)
	5240031420	22k Ω (X-2000M)
R329, R429	5240031420	22k Ω (X-2000M)
R330, R430	Δ 5183578000	100 Ω Nonflammable
R331, R431	5240033820	220k Ω
R332, R432	5240033020	100k Ω
R333, R433	5240031820	33k Ω
R334, R434	5240029420	3.3k Ω
R335	Δ 5183562000	22 Ω Nonflammable
R336, R436	5240025820	100 Ω
R337, R427	5240031220	18k Ω (X-2000M)
R338, R438	5240029020	2.2k Ω (X-2000M)
R339, R439	5240030620	10k Ω
R340, R440	5240030620	10k Ω
R341, R441	5240035220	820k Ω
R342, R442	5240034520	430k Ω
R343, R443	5240030320	7.5k Ω
R344, R444	5240029420	3.3k Ω
R345, R445	5240027620	560 Ω
R346	Δ 5183562000	22 Ω Nonflammable
R347, R447	5240025820	100 Ω
R348	5240031420	22k Ω
R349	5240031820	33k Ω
R350, R450	5240033020	100k Ω
R351, R451	5240033820	220k Ω
R352, R452	5240033020	100k Ω
R353, R453	5240031420	22k Ω
R354, R454	5240026620	220 Ω
R355	Δ 5183562000	22 Ω Nonflammable
R356, R456	5240033820	220k Ω
R357, R457	5240033020	100k Ω
R358, R458	5240028620	1.5k Ω

Parts marked with *require longer delivery time.

[U]: U.S.A.
[E]: EUROPE

[C]: CANADA
[UK]: U.K.

[GE]: GENERAL EXPORT
[L]: LIMITED AREA

[A]: AUSTRALIA
[J]: JAPAN

REF. NO.	PARTS NO.	DESCRIPTION
R359, R459	5240028220	1kΩ
R360	Δ 5183562000	22Ω Nonflammable
R361, R461	5240030220	6.8kΩ
R362, R462	5240032220	47kΩ
R363, R463	5240033020	100kΩ
R364, R464	5240032220	47kΩ
R365, R465	5240033020	100kΩ
R366, R466	5240025820	100Ω
R367	Δ 5183562000	22Ω Nonflammable
R368, R468	5240033020	100kΩ
R369, R469	5240032220	47kΩ
R370, R470	5181508000	12kΩ
R371, R471	5181510000	15kΩ
R372, R472	5181482000	1kΩ
R373, R473	5240033220	120kΩ
R374	5240028220	1kΩ
R375, R475	5240029820	4.7kΩ
R377	Δ 5183578000	100Ω Nonflammable
R378, R478	5240033820	220kΩ
R379, R479	5240033020	100kΩ
R381, R481	5240029820	4.7kΩ
R383, R483	5240029820	4.7kΩ
R384, R484	5240029820	4.7kΩ (X-2000M)
R385, R485	5240029820	4.7kΩ (X-2000)
	5240030620	10kΩ (X-2000M)
R386, R486	5240029820	4.7kΩ (X-2000M)
R387, R487	5240029820	4.7kΩ (X-2000)
	5240030620	10kΩ (X-2000M)
R388, R488	5240025820	100Ω
R390, R490	5240032220	47kΩ (X-2000)
R391, R491	5240028420	1.2kΩ
R392, R492	5240028820	1.8kΩ
R393, R493	5240033820	220kΩ
R394, R494	5240029020	2.2kΩ
R395, R495	5240029620	3.9kΩ
R396, R496	5240029020	2.2kΩ
R397	Δ 5183562000	22Ω Nonflammable
R398	5240025820	100Ω
R399	5240031020	15kΩ
R500	5240023420	10Ω
R503	5240028220	1kΩ
R504	5240029020	2.2kΩ
R505	5240032620	68kΩ
R506	5240033020	100kΩ
R507	5240031420	22kΩ
R508	5240029820	4.7kΩ
R510	5240033020	100kΩ
R512~R514	5240029820	4.7kΩ
R515	5240031420	22kΩ
R516~R519	5240030620	10kΩ
R520	5240030620	10kΩ (X-2000M)
R536, R936	5240030020	5.6kΩ
R537, R937	5240030620	10kΩ
R538, R938	5240025820	100Ω
R539, R939	5240033020	100kΩ
R540, R940	5240033820	220kΩ
R541, R941	5240030620	10kΩ
R542, R942	5240032220	47kΩ
R543, R943	5240032220	47kΩ

REF. NO.	PARTS NO.	DESCRIPTION
R544	5193562000	22Ω Nonflammable
R545	5240025820	100Ω
R546	5240029420	3.3kΩ
R547	5240031720	30kΩ
R548	5240025820	100Ω
R577, R977	5240029820	4.7kΩ
R578, R978	5240029820	4.7kΩ
R579	5240029820	4.7kΩ
R580, R980	5240031020	15kΩ
R581	5240025820	100Ω
R582	5240029820	4.7kΩ
R583, R983	5240025820	100Ω
R584, R984	5240028220	1kΩ
R585, R985	5240028220	1kΩ
R586, R986	5240029020	2.2kΩ
R587	5240031420	22kΩ
R588	5240032420	56kΩ
R589	5240030620	10kΩ
R590, R990	5240030020	5.6kΩ
R591, R991	5240030020	5.6kΩ
R592	5240033020	100kΩ
R593	5240033020	100kΩ
R594, R994	5240033820	220kΩ (X-2000)
R595, R995	5240033820	220kΩ
R596, R996	5240031220	18kΩ (X-2000)
R597	5240029020	2.2kΩ
R598	5240033020	100kΩ (X-2000M)
CAPACITORS		
C301, C401	5054656100	Dip Tantalum 10μF 16V
C302, C402	5260162650	Elec. 10μF 25V
C303, C403	5260222050	Elec. 10μF 35V
C304, C404	5173073000	Elec. 470μF 25V
C305, C405	5263106620	Polyst. 330pF 100V
C306, C406	5263106620	Polyst. 330pF 100V
C307, C407	5170006000	Dip Myca 68pF 50V
C308, C408	5263106420	Polyst. 270pF 100V
C309, C409	5263106420	Polyst. 270pF 100V
C310, C410	5054740000	Dip Myca 10pF 50V
C311, C411	5260223150	Elec. 47μF 16V
C312, C412	5263167223	Metalized 0.027μF 50V (X-2000)
	5267167123	Metalized 0.022μF 50V (X-2000M)
C313, C413	5260222050	Elec. 10μF 35V
C314, C414	5263167323	Metalized 0.033μF 50V (X-2000)
	5263167123	Metalized 0.022μF 50V (X-2000M)
C315, C415	5263102720	Polyst. 8200pF 100V
C316, C416	5263101720	Polyst. 3300pF 100V
C317	5260162650	Elec. 10μF 25V
C318, C418	5263106720	Polyst. 360pF 100V
C319, C419	5260221350	Elec. 2.2μF 50V
C320, C420	5260222050	Elec. 10μF 35V
C321, C421	5260221350	Elec. 2.2μF 50V
C322	5260162650	Elec. 10μF 25V
C323, C423	5263106420	Polyst. 270pF 100V
C324, C424	5263105620	Polyst. 120pF 100V
C325, C425	5260162050	Elec. 4.7μF 35V
C326	5260166752	Elec. 220μF 6.3V
C327	5173433000	Ceramic 0.01μF 50V
C328, C428	5263166123	Metalized 0.0033μF 50V
C329	5173070000	Elec. 470μF 6.3V

REF. NO.	PARTS NO.	DESCRIPTION
C330, C430	5260221350	Elec. 2.2μF 50V
C331, C431	5260220950	Elec. 0.47μF 50V
C332, C432	5260223150	Elec. 47μF 16V
C333	5260162650	Elec. 10μF 25V
C334, C434	5260221350	Elec. 2.2μF 50V
C335, C435	5260222650	Elec. 22μF 16V
C336, C436	5260223150	Elec. 47μF 25V
C337	5260162650	Elec. 10μF 25V
C338, C438	5260222050	Elec. 10μF 35V
C339, C439	5260221350	Elec. 2.2μF 50V
C340	5260162650	Elec. 10μF 25V
C341	5171856000	Mylar 0.01μF 100V
C342	5260067150	Elec. 10μF 25V
C343, C443	5263167523	Metalized 0.047μF 50V
C344, C444	5260221350	Elec. 2.2μF 50V
C345, C445	5263167123	Metalized 0.022μF 50V
C346, C446	5263167123	Metalized 0.022μF 50V (X-2000)
	5171858000	Mylar 0.012μF 100V (X-2000M)
C347, C447	5263167123	Metalized 0.022μF 50V (X-2000)
C348, C448	5263167123	Metalized 0.022μF 50V (X-2000)
	5171856000	Mylar 0.01μF 100V (X-2000M)
C349, C449	5171856000	Mylar 0.01μF 100V
C350, C450	5171856000	Mylar 0.01μF 100V
C351, C451	5171856000	Mylar 0.01μF 100V
C352, C452	5171856000	Mylar 0.01μF 100V (X-2000)
	5263166423	Metalized 0.0056μF 50V (X-2000M)
C353, C453	5263168323	Metalized 0.22μF 50V
C354, C454	5260222050	Elec. 10μF 35V
C355, C455	5260223150	Elec. 47μF 16V (X-2000)
	5263166523	Metalized 0.0068μF 50V (X-2000M)
C356, C456	5263101520	Polyst. 2700pF 100V
C357, C457	5263106720	Polyst. 360pF 100V
C359, C459	5263167323	Metalized 0.033μF 50V
C360, C460	5263167323	Metalized 0.033μF 50V (X-2000)
	5263100920	Polyst. 0.0015μF 100V (X-2000M)
C361, C461	5263167323	Metalized 0.033μF 50V (X-2000)
	5263107420	Polyst. 680pF 100V (X-2000M)
C362	5260162650	Elec. 10μF 25V
C363	5266013400	Dip Tantalum 10μF 35V
C364, C365	5260162650	Elec. 10μF 25V
C366	5260165052	Elec. 47μF 10V
C367	5260162550	Elec. 10μF 16V
C368, C468	5172204000	Ceramic 22pF 50V
C370	5054740000	Dip Mica 10pF 50V
C372	5260163452	Elec. 22μF 25V
C383, C483	5173433000	Ceramic 0.01μF 50V
C384	5173433000	Ceramic 0.01μF 50V
C385	5260162650	Elec. 10μF 25V
C386~C389	5173433000	Ceramic 0.01μF 50V
C392, C492	5260222050	Elec. 10μF 35V
C393, C493	5260221550	Elec. 4.7μF 35V
C394, C494	5260221350	Elec. 2.2μF 50V
C396, C496	5263101320	Polyst. 2200pF 100V

REF. NO.	PARTS NO.	DESCRIPTION
C397, C497	5260222050	Elec. 10μF 35V
C398	5260162650	Elec. 10μF 25V
C399	5173433000	Ceramic 0.01μF 50V
C502	5173433000	Ceramic 0.01μF 50V
C503, C903	5270222050	Elec. 10μF 35V
C504, C904	3263166723	Metalized 0.01μF 50V
C505, C905	5263166723	Metalized 0.01μF 50V
C506	5263166723	Metalized 0.01μF 50V
C507, C907	5054740000	Dip Myca 10pF 50V
C508	5260160750	Elec. 1μF 50V
C509, C909	5263101120	Polyst. 1800pF 100V
C510	5260067050	Elec. 10μF 16V
C511	5260162050	Elec. 4.7μF 35V (X-2000M)
VARIABLE RESISTORS		
R550, R950	5280021100	Semi-fixed 4.7kΩ(B)
R551, R951	5280021100	Semi-fixed 4.7kΩ(B) (X-2000M)
R554, R954	5280021700	Semi-fixed 47kΩ(B)
R555, R955	5280021700	Semi-fixed 47kΩ(B) (X-2000M)
R556, R956	5280021900	Semi-fixed 100kΩ(B)
R557, R957	5280022100	Semi-fixed 220kΩ(B)
R559, R959	5280021300	Semi-fixed 10kΩ(B) (X-2000)
	5280021500	Semi-fixed 22kΩ(B) (X-2000M)
R561, R961	5280021300	Semi-fixed 10kΩ(B)
R563, R963	5280020700	Semi-fixed 1kΩ(B)
R565, R965	5280020700	Semi-fixed 1kΩ(B)
R567, R967	5280020700	Semi-fixed 1kΩ(B)
R569, R969	5280020700	Semi-fixed 1kΩ(B)
R570, R970	5280021700	Semi-fixed 47kΩ(B)
R572, R972	5280022300	Semi-fixed 470kΩ(B)
R573, R973	5280022300	Semi-fixed 470kΩ(B)
R574	5280021700	Semi-fixed 47kΩ(B)
R576, R976	5280021700	Semi-fixed 47kΩ(B)
COILS		
L301, L401	5056659000	Trap, 3mH
L302, L402	5286007300	Choke, 2.2mH
L303	5286020200	Choke, 220μH
L304, L305	5056658100	Dummy, 3mH
L306, L406	5056659000	Trap, 3mH
CONNECTOR PLUGS		
P301	5122126000	2P (WHT) (X-2000)
	5122128000	4P (WHT) (X-2000M)
P302	5122128000	4P (WHT)
P303	5122126000	2P (WHT)
P401	5122299000	2P (RED) (X-2000)
	5122301000	4P (RED) (X-2000M)
P403	5122183000	2P (BLK)
MISCELLANEOUS		
U307	5292203000	OSC Unit
K301	5290010400	Relay 24V MR62-24S
K302, K303	5290010400	Relay 24V MR62-24S (X-2000)
S301	5302102500	Remote, Switch Ni SWE1248
S303, S403	5300038400	Push Switch, 2-2
S304, S404	5300035800	Push Switch, 6-6
S305	5300035900	Push Switch, 6-6
TP1~TP6	5544750000	Pin
TP11~TP15	5544750000	Pin

Parts marked with *require longer delivery time.

[U]: U.S.A.
[E]: EUROPE

[C]: CANADA [GE]: GENERAL EXPORT
[UK]: U.K. [L]: LIMITED AREA

[A]: AUSTRALIA
[J]: JAPAN

POWER PCB ASSY

REF. NO.	PARTS NO.	DESCRIPTION
	5200135410	PCB Assy (X-2000/X-2000B)
	*5200135420	PCB Assy (X-2000M)
	*5210135402	PCB
IC's		
U31	5220019700	LC7800
U32	5220804900	6402H-325
U33	5220805000	6405H-320
U43	5220419500	LA6358
U61	5220020500	LB1475
U222	6048968000	MC14066B
U223~U225	5220419500	LA6358
U226	5220021900	MC14584BCP
U230	6048932000	MC14011BCP
U231	△5220418900	L78N05
U232	△5220420900	L78N15
U233	6048932000	MC14011BCP
TRANSISTORS		
Q34, Q35	5230779720	2SC-945A KA
Q36~Q40	5230017920	2SC-733A PB
Q41~Q43	5231755400	2SD-794Q
Q44	5145129000	2SB-507E
Q45	5230779720	2SC-945A KA
Q120, Q121	5230017920	2SA-733A PB
Q122, Q123	5230778320	2SC-2320F
Q124	5145102000	2SK-68AL, FET
Q125	5145129000	2SB-507E
Q126	5145150000	2SA-1015GR
Q127	5230779720	2SC-945A KA
Q128	△5145087000	2SD-313E
Q129	5042625000	2SC-1318S
Q130	5230779720	2SC-945A KA
U34, U35	5232252020	2SC-3400, Digital
U36	5232251620	2SA-1346, Digital
U37	5232252020	2SC-3400, Digital
U38~U40	5232251620	2SA-1346, Digital
U41, U42	5232252020	2SC-3400, Digital
U45~U47	5232252020	2SC-3400, Digital
U48~U51	5232251620	2SA-1346, Digital
U55, U56	5232252020	2SC-3400, Digital
U62	5232250900	BA6251, Array
U220, U221	5232250900	BA6251, Array
U227	5232252020	2SC-3400, Digital
U228	5232251620	2SA-1346, Digital
U229	5232252020	2SC-3400, Digital
U234	5232252020	2SC-3400, Digital
DIODES		
D31, D32	5224015020	1SS133T-77
D36	5224015020	1SS133T-77
D39	5224013000	DSA26C
D40	5224015020	1SS133T-77
D41~D43	5224013210	DS135-D-FA4
D44	5224015020	1SS133T-77
D50	5224013210	DS135-D-FA4
D52	5224015020	1SS133T-77
D54	5224015020	1SS133T-77
D120	5224542101	RD9.1EB2, Zener (X-2000)

REF. NO.	PARTS NO.	DESCRIPTION
D121	5224015020	1SS133T-77 (X-2000)
D122	5224542101	RD9.1EB2, Zener
D123~D137	5224015020	1SS133T-77
D138~D140	5224013200	DS135-D
D141~D144	△5224013210	DS135-D-FA4
D145	5224015020	1SS133T-77
D146~D150	△5224013210	DS135-D-FA4
D151	5224540901	RD6.2EB2, Zener
D152	△5228009800	M4C-52-12
D153~D155	5224015020	1SS133T-77
D156	△5224013210	DS135-D-FA4
RESISTORS		
All resistors are rated ±5% tolerance, 1/4W and of carbon type unless others noted.		
R31	5240030620	10kΩ
R32	5240031420	22kΩ
R33	5240028220	1kΩ
R37~R39	5240030620	10kΩ
R40	5240026620	220Ω
R41, R42	5240023420	10Ω
R43	△5183554000	10Ω
R44	5240030020	5.6kΩ
R45	5240033020	100kΩ
R46	5240029820	4.7kΩ
R47	5240027020	330Ω
R48	5240031420	22kΩ
R49	5240032220	47kΩ
R50	5240033020	100kΩ
R51	5240031020	15kΩ
R52, R53	5240032220	47kΩ
R54	5240033020	100kΩ
R55	5240035420	1MΩ
R56	5184948000	4.7kΩ
R57~R59	5240030620	10kΩ
R60~R64	5240028220	1kΩ
R65~R67	5240027020	330Ω
R70	5240026220	150Ω
R71	5180062000	150Ω
R72	5240031420	22kΩ
R73	5180062000	150Ω
R74	5240031420	22kΩ
R75	5180062000	150Ω
R76	5240031420	22kΩ
R78	△5184594000	220Ω 1W, Metal Film
R79	5240028220	1kΩ
R80	5240032220	47kΩ
R81	5240028220	1kΩ
R84	5240030620	10kΩ
R85~R92	5240026220	150Ω
R98	5240027020	330Ω
R100	△5241230000	10Ω 1W, Nonflammable (X-2000M)
R120, R220	5240033020	100kΩ (X-2000)
R121, R221	5240032220	47kΩ (X-2000)
R123, R223	5240030620	10kΩ (X-2000)
R124, R224	5240033020	100kΩ (X-2000)
R125, R225	5240028220	1kΩ (X-2000)
R126, R226	5240030620	10kΩ (X-2000)
R127, R227	5240033020	100kΩ (X-2000)
R128, R228	5240033020	100kΩ (X-2000)
R129, R229	5240028220	1kΩ (X-2000)
R130, R230	5240033820	220kΩ (X-2000)
R131, R231	5240033820	220kΩ (X-2000)
R132, R232	5240032220	47kΩ (X-2000)
R133, R233	5240032220	47kΩ (X-2000)

Parts marked with *require longer delivery time.

[U]: U.S.A.
[E]: EUROPE

[C]: CANADA
[UK]: U.K.

[GE]: GENERAL EXPORT
[L]: LIMITED AREA

[A]: AUSTRALIA
[J]: JAPAN

REF. NO.	PARTS NO.	DESCRIPTION
R134, R234	5240030620	10kΩ
R135, R235	5240031420	22kΩ
R136, R236	5240030620	10kΩ
R137, R237	5240024220	22Ω
R138, R238	5240030620	10kΩ
R139, R239	5185190000	0.22Ω 2W, Metal Film
R140	5240027820	680Ω
R141, R142	5240030620	10kΩ
R143	5240031420	22kΩ
R144	5240033820	220kΩ
R145	5240033420	100Ω
R146	5240025820	100Ω
R147	5240027020	330Ω
R148	5240032020	39kΩ
R149	5240031420	22kΩ
R151	5240029020	2.2kΩ
R152	5240027820	680Ω
R153	5240033020	100kΩ
R154	5240176600	3.3MΩ
R155	5240025820	100Ω
R156	5240030620	10kΩ
R157	5240030420	8.2kΩ
R158	5240030620	10kΩ
R159, R160	5240029420	3.3kΩ
R161	△ 5241206600	4.7kΩ 1W, Metal Film
R162	5240032220	47kΩ
R163	5240027620	560Ω
R164	5240027820	680Ω
R165	△ 5241240400	15Ω 2W, Metal Film
R166	△ 5184550000	1Ω 2W, Metal Film
R167	5240030220	6.8kΩ
R168	5240030620	10kΩ
R169	5240031220	18kΩ
R170	5240030220	6.8kΩ
R171	5240029620	3.9kΩ
R172	△ 5183562000	22Ω Nonflammable
R173	△ 5241231200	33Ω 1W, Metal Film
R174	5240030620	10kΩ
R240, R241	5240033020	100kΩ
R242	5240035420	1MΩ
R243, R244	5240032220	47kΩ
R245, R246	5240031420	22kΩ
R247, R248	5240031820	33kΩ
R249, R250	5240033020	100kΩ
R251, R252	5240031820	33kΩ
R253	5240031420	22kΩ
R254	5240031820	33kΩ
R256	5240031820	33kΩ
R258	5240031420	22kΩ
R259~R263	5240031820	33kΩ
R264	5240030620	10kΩ
R265~R271	5240031420	22kΩ
R272, R273	5240033020	100kΩ
R274	5240030620	10kΩ
U63, U64	5242111700	10kΩx8, Array
U65	5293002700	01-0397, Array
U66	5293002600	01-0396, Array
CAPACITORS		
C31, C32	5260165952	Elec. 100μF 10V
C33	5260162550	Elec. 10μF 16V
C37, C38	5263106220	Polyst. 220pF 100V
C41, C42	5173433000	Ceramic 0.01μF 50V
C44~C48	5173433000	Ceramic 0.01μF 50V

REF. NO.	PARTS NO.	DESCRIPTION
C120, C220	5263167623	Metalized 0.056μF 50V
C121, C221	5263168523	Metalized 0.33μF 50V
C122, C222	5263167923	Metalized 0.1μF 50V
C123, C223	5263166523	Metalized 0.0068μF 50V
C124, C224	5263167923	Metalized 0.1μF 50V
C125, C225	5260067350	Elec. 10μF 50V
C126, C226	5173433000	Ceramic 0.01μF 50V
C127, C227	5173433000	Ceramic 0.01μF 50V
C128	5263107220	Polyst. 560pF 100V
C129	5263167923	Metalized 0.1μF 50V
C130	5260160550	Elec. 0.47μF 50V
C131	5263165723	Metalized 0.0015μF 50V
C132	5260160550	Elec. 0.47μF 50V
C133	5260161150	Elec. 2.2μF 50V
C134	5260165052	Elec. 47μF 10V
C135	5173054800	Elec. 220μF 16V
C136	△ 5173088000	Elec. 2200μF 16V
C139	5267010300	Ceramic 10000pF 500V
C142	△ 5260271810	Elec. 2200μF 50V
C145	5260163552	Elec. 22μF 35V
C146	5260165052	Elec. 47μF 10V
C147, C148	5173056800	Elec. 220μF 35V
C149	5260162050	Elec. 4.7μF 35V
C151	△ 5260271810	Elec. 2200μF 50V
C153	5263107220	Polyst. 560pF 100V
C154	△ 5262008900	Elec. 4700μF 25V
C155	△ 5173075000	Elec. 470μF 50V
C156, C157	5260162050	Elec. 4.7μF 35V
C158	5173048800	Elec. 100μF 50V
C228, C229	5260160550	Elec. 0.47μF 50V
C230	5260161550	Elec. 3.3μF 50V
VARIABLE RESISTORS		
R123, R223	5280132302	Semi-fixed 20kΩ(B)
R150	5150156000	Semi-fixed 50kΩ(B)
R255	5150154000	Semi-fixed 10kΩ(B)
R257	5150154000	Semi-fixed 10kΩ(B)
CONNECTOR PLUGS		
P32	5122145000	2P (WHT) (X-2000M)
P33	5122147000	4P (WHT)
P34	5122203000	3P (BLK)
P35	5122147000	4P (WHT)
P36	5122202000	2P (BLK)
P37	5122453000	2P (RED)
P38	5122454000	3P (RED)
P39	5122153000	10P (WHT)
P40	5122208000	8P (BLK)
P41	5122460000	9P (RED)
P43	5122148000	5P (WHT)
P44	5122157000	14P (WHT)
P120	5122146000	3P (WHT)
P121	5122454000	3P (RED)
P122	5122204000	4P (BLK)
P123, P124	5122203000	3P (BLK)
P125	5122149000	6P (WHT)
MISCELLANEOUS		
CR31	5347000900	Seramic OSC, KBR-800H
K30	5290008500	Relay, 24V, G2U-112P
	5290011000	Relay, 24V, MR31-24U
L31	5286016500	Choke, Coil; 100MH T-8
TP1	5544750000	Pin

Parts marked with *require longer delivery time.

[U]: U.S.A.
[E]: EUROPE

[C]: CANADA
[UK]: U.K.

[GE]: GENERAL EXPORT
[L]: LIMITED AREA

[A]: AUSTRALIA
[J]: JAPAN

DBX PCB ASSY

REF. NO.	PARTS NO.	DESCRIPTION
	*5200135600	PCB Assy
	*5210135600	PCB
	IC's	
U601, U602	5220414501	μPC1252H-2
U603, U604	5220414601	μPC1253H-2
U605, U606	5220418800	M5218P
U701, U702	5220414501	μPC1252H-2
U703, U704	5220414601	μPC1253H-2
U705	5220418800	M5218P
	TRANSISTORS	
Q601~Q604	5230778300	2SC2320F
Q701~Q704	5230778300	2SC2320F
	CARBON RESISTORS	
All resistors are rated ±5% tolerance and ¼W.		
R601, R602	5240033020	100kΩ
R603, R604	5240025820	100Ω
R605, R606	5240033220	120kΩ
R607, R608	5240030020	5.6kΩ
R609, R610	5240031820	33kΩ
R611, R612	5240030620	10kΩ
R613, R614	5240024420	27kΩ
R615~R618	5240024220	22kΩ
R619, R620	5240030620	10kΩ
R621, R622	5240030820	12kΩ
R625, R626	5240032420	56kΩ
R629, R630	5240029620	3.8kΩ
R631, R632	5240030620	10kΩ
R633, R634	5240031820	33kΩ
R635, R636	5240025820	100Ω
R637, R638	5240033020	100kΩ
R639, R640	5240029020	2.2kΩ
R641, R642	5240029220	2.7kΩ
R634, R644	5240030220	6.8kΩ
R645, R646	5240025820	100Ω
R647, R648	5240029820	4.7kΩ
R649, R650	5240029220	2.7kΩ
R651, R652	5240031520	24kΩ
R655, R656	5240031320	20kΩ
R657, R658	5240177800	10MΩ
R659, R660	5240032020	39kΩ
R661, R662	5240024220	22Ω
R663, R664	5240034620	470kΩ
R665, R666	5240028220	1kΩ
R667, R668	5240175800	1.5MΩ
R669, R670	5240033020	100kΩ
R671, R672	5240023420	10Ω
R673, R674	5240033820	220kΩ
R575, R676	5240032520	62kΩ
R677	5240027420	470Ω
R679, R680	5240177800	10MΩ
R681	▲5183562000	22Ω
R682, R683	5240030620	10kΩ
R701, R702	5240033020	100kΩ
R703, R704	5240025820	100Ω
R705, R706	5240033220	120kΩ
R707, R708	5240030020	5.6kΩ
R709, R710	5240031820	33kΩ
R711, R712	5240030620	10kΩ
R713, R714	5240024420	27kΩ

Nonflammable

REF. NO.	PARTS NO.	DESCRIPTION
R715~R718	5240024220	22Ω
R719, R720	5240030620	10kΩ
R721, R722	5240030820	12kΩ
R725, R726	5240324200	56kΩ
R729, R730	5240029620	3.9kΩ
R731, R732	5240030620	10kΩ
R733, R734	5240031820	33kΩ
R735, R736	5240025820	100Ω
R737, R738	5240033020	100kΩ
R739, R740	5240029020	2.2kΩ
R741, R742	5240029220	2.7kΩ
R743, R744	5240030220	6.8kΩ
R745, R746	5240025820	100Ω
R747, R748	5240029820	4.7kΩ
R749, R750	5240029220	2.7kΩ
R751, R752	5240031520	24kΩ
R755, R756	5240031320	20kΩ
R757, R758	5240177800	10MΩ
R759, R760	5240032020	39kΩ
R761, R762	5240024220	22Ω
R763, R764	5240034620	470kΩ
R765, R766	5240028220	1kΩ
R767, R768	5240175800	1.5MΩ
R769, R770	5240033020	100kΩ
R771, R772	5240023420	10Ω
R773, R774	5240032520	62kΩ
R775, R776	5240033820	220kΩ
R777	5240027420	470Ω
R779, R780	5241177800	10MΩ
R781, R782	5240031920	36kΩ
R783, R784	5240030620	10kΩ
	CAPACITORS	
C601, C602	5260222050	Elec. 10μF 35V
C603, C604	5263169113	Metalized 1μF 50V
C605, C606	5263106120	Polyst. 200pF 100V
C607, C608	5263166723	Metalized 0.01μF 50V
C609, C610	5263105420	Polyst. 100pF 100V
C611, C612	5260222050	Elec. 10μF 35V
C613~C616	5263167723	Metalized 0.068μF 50V
C617~C620	5263166123	Metalized 3300pF 50V
C621, C622	5263107220	Polyst. 560pF 100V
C623, C624	5263168023	Metalized 0.12μF 50V
C625, C626	5263166123	Metalized 3300pF 50V
C627, C628	5260160750	Elec. 1μF 50V
C629, C630	5260162650	Elec. 10μF 25V
C631, C632	5260227010	Elec. 10μF 35V
C633~C636	5260165252	Elec. 47μF 25V
C637, C638	5260166723	Metalized 0.01μF 50V
C640	5173082000	Elec. 1000μF 25V
C641	5260162550	Elec. 10μF 16V
C703, C704	5263169113	Metalized 1μF 50V
C705, C706	5263166723	Metalized 0.01μF 50V
C707~C710	5263105420	Polyst. 100pF 100V
C711, C712	5260222050	Elec. 10μF 35V
C713~C716	5263167723	Metalized 0.068μF 50V
C717~C720	5263166123	Metalized 3300pF 50V
C721, C722	5263107220	Polyst. 560pF 100V
C723, C734	5263168023	Metalized 0.12μF 50V
C725, C726	5263166123	Metalized 3300pF 50V
C727, C728	5260160750	Elec. 1μF 50V
C729, C730	5260162650	Elec. 10μF 25V
C731, C732	5260227010	Elec. 10μF 35V

Parts marked with *require longer delivery time.

[U]: U.S.A.
[E]: EUROPE

[C]: CANADA
[UK]: U.K.

[GE]: GENERAL EXPORT
[L]: LIMITED AREA

[A]: AUSTRALIA
[J]: JAPAN

REF. NO.	PARTS NO.	DESCRIPTION
C733~C736	5260165252	Elec. 47 μ F 25V
C737, C738	5263166723	Metalized 0.01 μ F 50V
C739~C742	5263168023	Metalized 0.12 μ F 50V
C734	5260162550	Elec. 10 μ F 16V
VARIABLE RESISTORS		
R623, R624	5150154000	Semi-fixed 10k Ω (B)
R627, R628	5150094000	Semi-fixed 50k Ω (B)
R653, R654	5150094000	Semi-fixed 50k Ω (B)
R723, R724	5150154000	Semi-fixed 10k Ω (B)
R727, R728	5150094000	Semi-fixed 50k Ω (B)
R753, R754	5150094000	Semi-fixed 50k Ω (B)
CONNECTOR PLUGS		
P601	5122128000	4P (WHT)
P603	5122301000	4P (RED)
P605	5122299000	2P (RED)
P701	5122129000	5P (WHT)
P703	5122302000	5P (RED)

HEADPHONE PCB ASSY

REF. NO.	PARTS NO.	DESCRIPTION
	*5200135700	PCB Assy
	*5210135700	PCB
IC's		
U309, U310	5220418800	M5218P
TRANSISTORS		
Q319, Q419	5230016300	2SA937LNFR
Q323, Q423	5230780300	2SC2021LNR
U336, U436	5232252020	2SC3400, Digital
U337	5232251620	2SA1346, Digital
DIODES		
D312, D412	5224015010	1SS133HV
D313, D413	5224015010	1SS133HV
D314, D414	5224015400	1K60
D315, D415	5224015400	1K60
D316, D317	5224015010	1SS133HV
CARBON RESISTORS		
All resistors are rated $\pm 5\%$ tolerance and $\frac{1}{4}W$.		
R372, R472	5240030620	10k Ω
R515, R915	5240033020	100k Ω
R516, R916	5240033820	220k Ω
R517, R917	5240030620	10k Ω
R518, R918	5240030620	10k Ω
R519, R919	5240032620	68k Ω
R521, R921	5240024220	22 Ω
R522, R922	5240024220	22 Ω
R524, R924	5240030620	10k Ω
R525, R925	5240027420	470 Ω
R526, R926	5240027400	470 Ω
R527	Δ 5183566000	33 Ω
R528	5240033020	100k Ω
R529	5240033820	220k Ω
R530, R930	5240033020	100 Ω
R531, R931	5240028620	1.5k Ω
R533, R933	5240031420	22k Ω
R534	Δ 5183578000	100 Ω
R535	5240031420	22k Ω
R594, R994	5240030620	10k Ω
CAPACITORS		
C374, C474	5260212450	Elec. 10 μ F 25V
C375, C475	5260212450	Elec. 10 μ F 25V
C376, C476	5260165252	Elec. 47 μ F 25V
C377	5260212450	Elec. 10 μ F 25V
C378, D478	5260220950	Elec. 0.47 μ F 50V
C379, C479	5260212450	Elec. 10 μ F 25V
C380, C381	5260212450	Elec. 10 μ F 25V
C382, C482	5260212450	Elec. 10 μ F 25V
C390	5260212450	Elec. 10 μ F 25V
C510, C910	5054740000	Dip Myca 10pF 50V
C511, C512	5260213150	Elec. 22 μ F 25V
C513, C913	5263106020	Polyst. 180pF 100V
VARIABLE RESISTORS		
R558, R958	5280021900	Semi-fixed 100k Ω (B)
MISCELLANEOUS		
	5330010100	Jack, Headphone
	5330009400	Jack Mic

Parts marked with *require longer delivery time.

[U]: U.S.A.
[E]: EUROPE

[C]: CANADA
[UK]: U.K.

[GE]: GENERAL EXPORT
[L]: LIMITED AREA

[A]: AUSTRALIA
[J]: JAPAN

SPooling PCB ASSY

REF. NO.	PARTS NO.	DESCRIPTION
	*5200154311	PCB Assy (X-2000M)
	*5200154301	PCB Assy (X-2000/X-2000B)
	*5210154301	PCB
IC		
U1	5220016100	HD14013BP
TRANSISTORS		
Q1	5230779720	2SC-945A KA (X-2000M)
Q2	5230014000	2SA-1020Y (X-2000M)
Q3	5230773800	2SC-2655Y (X-2000M)
Q4	5230014000	2SA-1020Y (X-2000M)
Q5	5230773800	2SC-2655Y (X-2000M)
Q6	5230779720	2SC-945A KA (X-2000M)
U2	5232251620	2SA-1346, Digital
U3	5232252020	2SC-3400, Digital
U4	5232251620	2SA-1346, Digital
U5~U7	5232252020	2SC-3400, Digital
U5	5232252020	2SC-3400, Digital (X-2000/X-2000B)
U8, U9	5232251620	2SA-1346, Digital (X-2000M)
U10~U12	5232252020	2SC-3400, Digital (X-2000M)
U10	5232252020	2SC-3400, Digital (X-2000/X-2000B)
DIODES		
D1~D3	5224015020	1SS133T-77
D4~D11	5224013210	DS135-D-FA4 (X-2000M)
D12	5224015020	1SS133T-77
CARBON RESISTORS		
All resistors are rated $\pm 5\%$ tolerance and $\frac{1}{4}W$.		
R1	5240026220	150 Ω
R2	5240028220	1k Ω
R3, R4	5240030620	10k Ω
R5	5240031420	22k Ω (X-2000M)
R6	5240028620	1.5k Ω (X-2000M)
R7	5240031420	22k Ω (X-2000M)
R8	5240027020	330 Ω (X-2000M)
R9	5240028620	1.5k Ω (X-2000M)
R10	5240031420	22k Ω (X-2000M)
R11	5240027020	330 Ω (X-2000M)
R12, R13	5240031420	22k Ω (X-2000M)
R14	5240027620	560 Ω (X-2000M)
R15	5240031420	22k Ω (X-2000M)
R16	5240027620	560 Ω (X-2000M)
R17, R18	5240031420	22k Ω (X-2000M)
R19	5240030620	10k Ω
R20, R21	5240033020	100k Ω (X-2000M)
CAPACITORS		
C1, C2	5260160750	Elec. 1 μ F 50V
C3	5173433000	Ceramic 0.01 μ F 50V
C4	5260162550	Elec. 10 μ F 16V
C5	5260162850	Elec. 10 μ F 50V (X-2000M)
C6, C7	5260161150	Elec. 2.2 μ F 50V (X-2000M)
CONNECTOR PLUGS		
P1	5122149000	6P (WHT)
P2	5122453000	2P (RED) (X-2000M)
P3	5122145000	2P (WHT) (X-2000M)
P4	5122146000	3P (WHT) (X-2000M)
P5	5122147000	4P (WHT)

Parts marked with *require longer delivery time.

[U]: U.S.A.
[E]: EUROPE

NAB/IEC PCB ASSY (X-2000M)

REF. NO.	PARTS NO.	DESCRIPTION
	*5200154200	PCB Assy (X-2000M)
	*5210154200	PCB
TRANSISTORS		
Q101, Q102	5232007200	2SK-364BL, FET
U101	5232251920	2SA-3399, Digital
U102	5232251520	2SA-1345, Digital
U103~U106	5232251400	DTC143TF, Digital
DIODES		
D101~D106	5224015020	1SS133T-77
CARBON RESISTORS		
All resistors are rated $\pm 5\%$ tolerance and $\frac{1}{4}W$.		
R101, R102	5240032220	47k Ω
R103	5240033020	100k Ω
R104	5240033820	220k Ω
R105, R106	5240032220	47k Ω
R107, R108	5240031220	18k Ω
R109, R110	5240029020	2.2k Ω
CAPACITORS		
C101, C102	5263101520	Polyst. 0.0027 μ F 100V
C103, C104	5263167323	Metalized 0.033 μ F 50V
MISCELLANEOUS		
S101, S102	5300909200	Switch, Slide; 2-2N
P304	5122204000	Connector Plug, 4P (BLK)

PITCH CONT. PCB ASSY (PC Board omitted)

REF. NO.	PARTS NO.	DESCRIPTION
	*5200154400	PCB Assy
	*5210154400	PCB
R801	5282250700	Var. Res. Semi-fixed; 5k Ω (B) Switch Type
P803	5122145000	Connector Plug, 2P (WHT)

HEAD PCB ASSY (X-2000M) (PC Board omitted)

REF. NO.	PARTS NO.	DESCRIPTION
	*5200154500	PCB Assy (X-2000M)
	*5210154500	PCB
S803	5301205201	Switch, Rotary; 2-2

[C]: CANADA
[UK]: U.K.

[GE]: GENERAL EXPORT
[L]: LIMITED AREA

[A]: AUSTRALIA
[J]: JAPAN

OPERATION PCB ASSY

REF. NO.	PARTS NO.	DESCRIPTION
	*5200135910	PCB Assy
	*5210135901	PCB
D810	5225007100	LED, GL-9NG2 (GRN)
D812~D815	5225007900	LED, GL-9NR2 (RED)
S810~S818	6051083000	Switch, Tact

VOLUME PCB ASSY

REF. NO.	PARTS NO.	DESCRIPTION
	*5200135800	PCB Assy
	*5210135800	PCB
VARIABLE RESISTORS		
VR01~VR03	5282707200	50kΩ(A) x 2

COUNTER PCB ASSY

REF. NO.	PARTS NO.	DESCRIPTION
	*5200136000	PCB Assy
	*5210136000	PCB
U800	5225013000	LED, Indicator; GL-3E508A
D816, D817	5225013200	LED, GL-9PR24 (RED)
S819~S824	5138011000	Switch, Tact; AKC-8S

DUPLI SYNC PCB ASSY

REF. NO.	PARTS NO.	DESCRIPTION
	*5200142310	PCB Assy
	*5210142300	PCB
J805	5334025000	Pin Socket 5P

POWER SWITCH PCB ASSY (PC Board omitted)

REF. NO.	PARTS NO.	DESCRIPTION
	*5200113110	PCB Assy [U]
	*5200113120	PCB Assy [C]
	*5200113100	PCB Assy [J, GE, L]
	*5200141900	PCB Assy [E, UK, A]
	*5260073201	PCB [U, C, J, GE, L]
	*5210104801	PCB [E, UK, A]
S1	△ 5300030800	Push Switch, Power
Z1	△ 5052910000	Spark Killer 0.033μF+120Ω/125V [U]
	△ 5292002600	Spark Killer 0.033μF+120Ω/125 [C]
	△ 5052907000	Spark Killer 0.01μF+300Ω/300V [J, GE, L]
	△ 5267702500	Spark Killer 0.0047μF/250V [E, UK, A]

FUSE PCB ASSY (PC Board omitted)

REF. NO.	PARTS NO.	DESCRIPTION
	*5200140401	PCB Assy [E, UK, A]
	*5200140501	PCB Assy [U, C]
	*5210140401	PCB [E, UK, A]
	*5210140501	PCB [U, C]
F1, F2	△ 5041138000	Mini Fuse, 500mA 250V [E, UK, A]
F3	△ 5041140000	Mini Fuse, 1A 250V [E, UK, A]
F4	△ 5142193000	Mini Fuse, 5A 250V [E, UK, A]
F5	△ 5142192000	Mini Fuse, 4A 250V [E, UK, A]
F6, F7	△ 5307019900	T Type Fuse, 0.5A 250V [U, C]
F8	△ 5307020400	T Type Fuse, 1A 250V [U, C]
F9	△ 5307021700	T Type Fuse, 5A 250V [U, C]
F10	△ 5307021600	T Type Fuse, 4A 250V [U, C]
	5142087000	Fuse Holder [E, UK, A]
	5041237000	Fuse Holder [U, C]

TENSION SENSOR PCB ASSY (PC Board omitted)

REF. NO.	PARTS NO.	DESCRIPTION
	*5200067402	PCB Assy
	*5210067402	PCB
RESISTORS		
All resistors are rated ±5% tolerance, ¼W and of carbon type unless otherwise noted.		
R810, R811	5241426602	5.1kΩ, Metal Film
R812	5183080000	820Ω
R813	5183099000	5.1kΩ
MISCELLANEOUS		
U810	6048807000	Photo Interrupter, ON1102

Parts marked with *require longer delivery time.

[U]: U.S.A.
[E]: EUROPE

[C]: CANADA
[UK]: U.K.

[GE]: GENERAL EXPORT
[L]: LIMITED AREA

[A]: AUSTRALIA
[J]: JAPAN

SPEED SWITCH PCB ASSY (PC Board omitted)

REF. NO.	PARTS NO.	DESCRIPTION
	*5200136200	PCB Assy
	*5210136200	PCB
S801	5300036100	Push Switch, 4-4
S802	5300036200	Push switch, 2-1N
P801	5122454000	Connector Plug, 3P (RED)
P802	5122147000	Connector Plug, 4P (WHT)

DBX SWITCH PCB ASSY (PC Board omitted)

REF. NO.	PARTS NO.	DESCRIPTION
	*5200136700	PCB Assy
	*5210136700	PCB
S306	5300036000	Push Switch, 6-6

BIAS VR PCB ASSY (PC Board omitted)

REF. NO.	PARTS NO.	DESCRIPTION
	*5200136500	PCB Assy
	*5210136500	PCB
VR04	5282250500	Variable Resistor 5kΩ(B)

DBX LAMP PCB ASSY (PC Board omitted)

REF. NO.	PARTS NO.	DESCRIPTION
	*5200136600	PCB Assy
	*5210136600	PCB
DS02	5310006900	Lamp

TRANSISTOR PCB ASSY (PC Board omitted)

REF. NO.	PARTS NO.	DESCRIPTION
	*5200073100	PCB Assy
	*5210073100	PCB
Q801	5145171000	Transistor 2SD7180

IN/OUTPUT PCB ASSY (PC Board omitted)

REF. NO.	PARTS NO.	DESCRIPTION
	*5200136400	PCB Assy
	*5210136400	PCB
	5330508500	Pin Jack, 4P

VOLT. SELC. PCB ASSY(PC Board omitted)

REF. NO.	PARTS NO.	DESCRIPTION
	*5200140600	PCB Assy [GE, L]
	*5210140600	PCB
S402	△ 5302101700	Voltage Selector Switch
F401	△ 5041155000	Mini Fuse, 2A 250V
	5142087000	Fuse Holder

ROLLER SENSOR PCB ASSY (PC Board omitted)

REF. NO.	PARTS NO.	DESCRIPTION
	*5200136100	PCB Assy
	*5210136100	PCB
U801, U802	5228009600	Photo Interrupter, SPI-208

Parts marked with *require longer delivery time.

[U]: U.S.A.
[E]: EUROPE

[C]: CANADA
[UK]: U.K.

[GE]: GENERAL EXPORT
[L]: LIMITED AREA

[A]: AUSTRALIA
[J]: JAPAN

X-2000M/X-2000

TEAC®

ティアック株式会社

本社
営業部

180・東京都武蔵野市中町3-7-3

電話 武蔵野 (0422) 53-1111代

製品についてのお問い合わせ
サービスに関するお問い合わせ

札幌営業所	064・札幌市中央区南7条西2-2くぼたビル	電話 札幌 (011) 521-4101代
仙台営業所	980・仙台市1番町2-5-5中央ビル	電話 仙台 (0222) 27-1501代
東京営業所	100・東京都千代田区永田町2-10-7星ガ岡会館	電話 東京 (03) 592-1831代
三鷹出張所	180・東京都武蔵野市中町3-7-3	電話 武蔵野 (0422) 55-1610代
千葉出張所	280・千葉市松波1-11-3石橋松波ビル	電話 千葉 (0472) 55-1281代
横浜営業所	221・横浜市神奈川区沢渡1-1高島台第一ビル	電話 横浜 (045) 312-3270代
名古屋営業所	464・名古屋市千種区東山通り3-2-3	電話 名古屋 (052) 782-4581代
静岡出張所	420・静岡市中島大割2-8-61-1	電話 静岡 (0542) 81-6561代
大阪営業所	564・大阪府吹田市垂水町3-34-10	電話 大阪 (06) 384-5201代
京都出張所	600・京都市下京区大宮通四條下ル四條大宮町21番地三虎ビル	電話 京都 (075) 842-0751代
岡山出張所	700・岡山市青江5-1-2番1号	電話 岡山 (0862) 25-8601代
広島営業所	733・広島市中区中島町10-24	電話 広島 (082) 243-3581代
福岡営業所	812・福岡市博多区博多駅東2-17-5モリメンビル	電話 福岡 (092) 431-5781代

サービスに関するお問い合わせ

本社サービス1課 180・東京都武蔵野市中町3-7-3
沖縄サービスセンター 901-22・沖縄県宜野湾市字喜友名2-2-9

電話 武蔵野 (0422) 53-3242代

技術的なお問い合わせ

テープデッキ相談室 180・東京都武蔵野市中町3-7-3

電話 武蔵野 (0422) 53-9213代

TEAC CORPORATION

3-7-3 NAKA-CHO MUSASHINO TOKYO PHONE (0422) 53-1111

TEAC CORPORATION OF AMERICA

7733 TELEGRAPH ROAD MONTEBELLO CALIFORNIA 90640 PHONE (213) 726-0303

TEAC CANADA LTD.

3610 NASHUA DRIVE UNIT 1 & 2 MISSISSAUGA ONTARIO L4V 1L2 PHONE 416-673-3303

TEAC AUSTRALIA PTY., LTD.

115 WHITEMAN STREET SOUTH MELBOURNE VICTORIA 3205 PHONE 699-6000





PRINTED IN JAPAN 1084 AO 1.91 D-4709A

SCHEMATIC DIAGRAMS





X-2000M/X-2000

INSTRUCTIONS FOR SERVICE PERSONNEL
BEFORE RETURNING APPLIANCE TO THE CUSTOMER, MAKE LEAKAGE-CURRENT OR RESISTANCE MEASUREMENTS TO DETERMINE THAT EXPOSED PARTS ARE ACCEPTABLY INSULATED FROM THE SUPPLY CIRCUIT.

NOTES

1. Schematic diagram of the amplifier section shown for left channel except for some of the components.
2. All resistors are $\frac{1}{4}$ watt, $\pm 5\%$, unless marked otherwise. Resistor values are in ohms ($k = 1,000$ ohms).
3. All capacitor values are in microfarads ($p =$ picofarads).
4. Δ Parts marked with this sign are safety critical components. They must always be replaced with identical components-refer to the TEAC parts list and ensure exact replacement.
5. Voltage and level values are for reference only.
0dB = 0.775V
Indicated values are those existing when the meter indicates 0VU.
6.  : front panel indication
7.  : rear panel indication
8.  : +B power supply circuit.
9.  : -B power supply circuit.

注.

1. アンプ回路はLchのみが示されています。
2. 抵抗の単位は Ω ($k = k\Omega$, $M = M\Omega$).
特に指定のない限り, $1/4W$ 型, 偏差は $\pm 5\%$.
3. コンデンサの単位は μF ($p = pF$).
(BP): バイポーラ・コンデンサ
(CE): セラミック・コンデンサ
特に指定のないコンデンサは, 偏差 $\pm 5\%$ のマイラ・コンデンサ.
4. 電圧値および信号レベルは参考値です.
0dB = 0.775V
5. Δ マークのある部品は安全重要部品です.
交換するときは必ずティアック指定の部品を使用してください.
6.  : フロント・パネル上の表示
7.  : リア・パネル上の表示
8.  : +B 電源回路
9.  : -B 電源回路

TEAC[®]

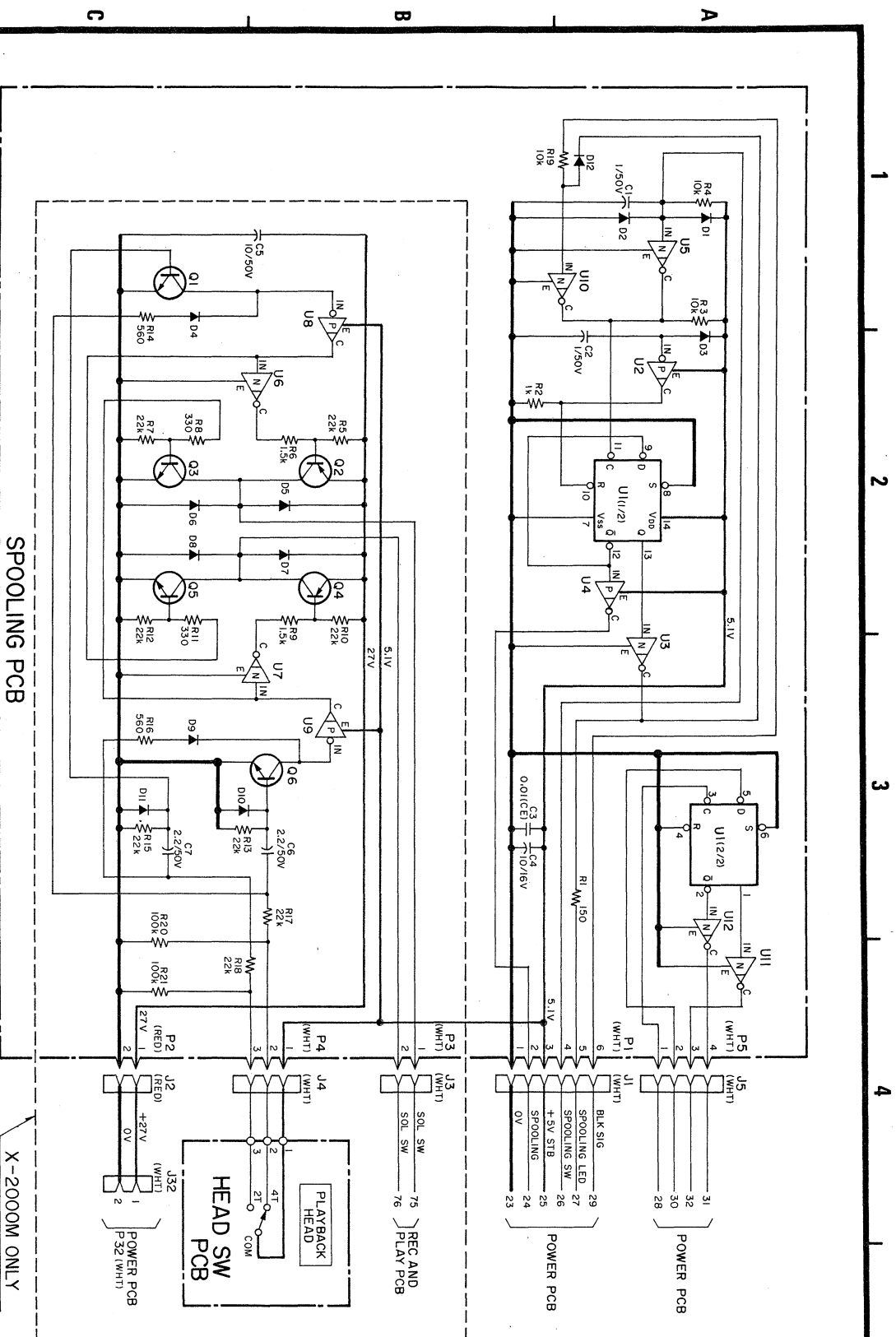

- U1 : HD14013BP
- U2, U4, U8, U9 : 2SA1346
- U3, U5~U7, U10~U12 : 2SC3400
- Q1, Q6 : 2SC945(K)
- Q2, Q4 : 2SA1020(Y)
- Q3, Q5 : 2SC2655(Y)
- D1~D3, D12 : 1SS133
- D4~D11 : DS1350

SPOOLING PCB

X-2000M ONLY

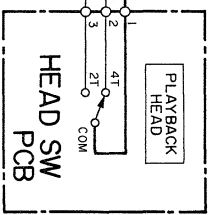

X-2000M/X-2000

Stereo Tape Deck

TEAC SCHEMATIC DIAGRAM (NAB/IEC) X-2000M

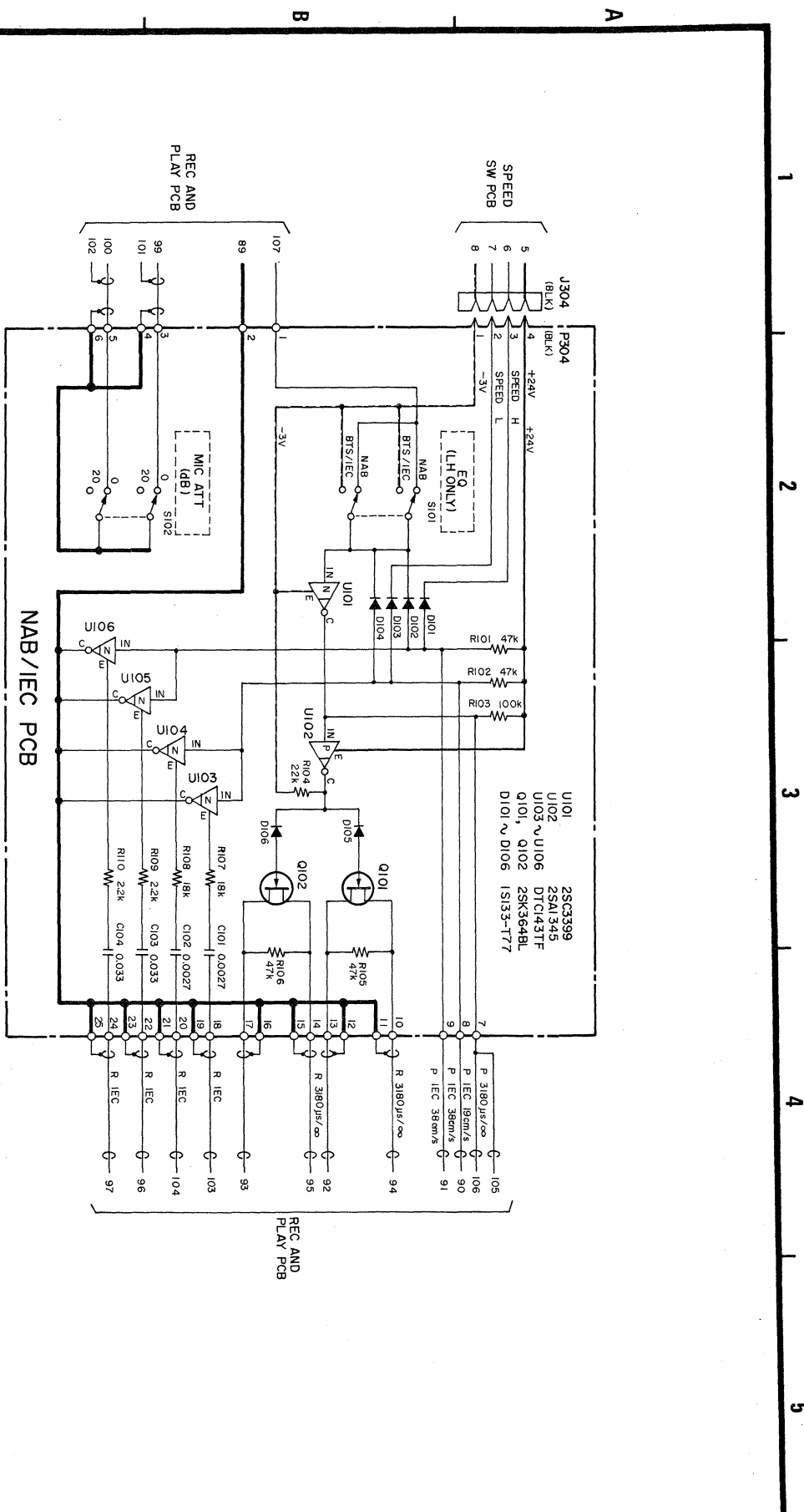

X-2000M

Stereo Tape Deck

2nd Issue, November, 1984

TEAC SCHEMATIC DIAGRAM (DBX) X-2000M/X-2000

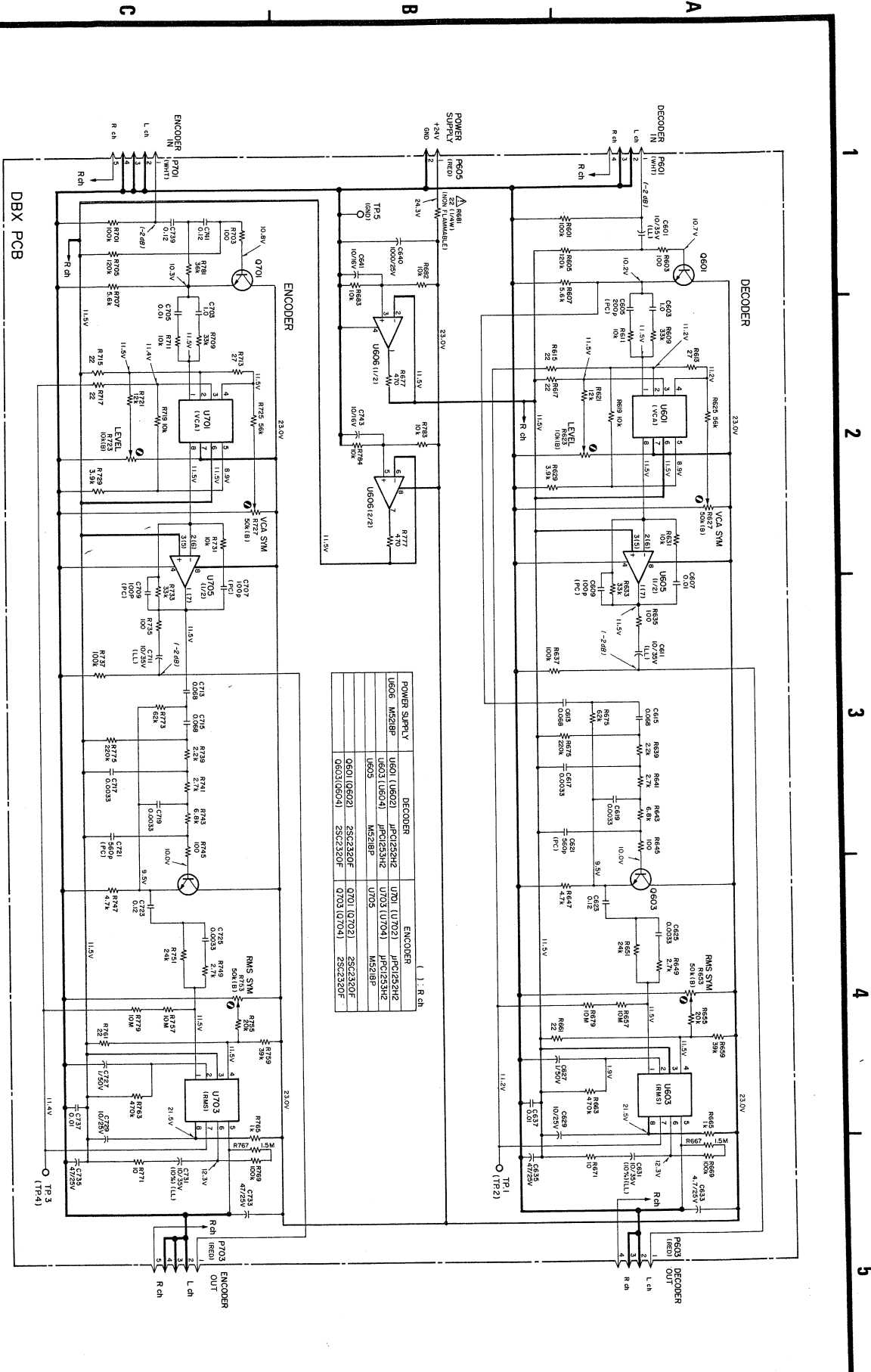

1 2 3 4 5

A

B

C

DBX PCB

X-2000M/X-2000 Stereo Tape Deck

2nd Issue; November, 1984

D

TEAC SCHEMATIC DIAGRAM (REC/PLAY) X-2000M

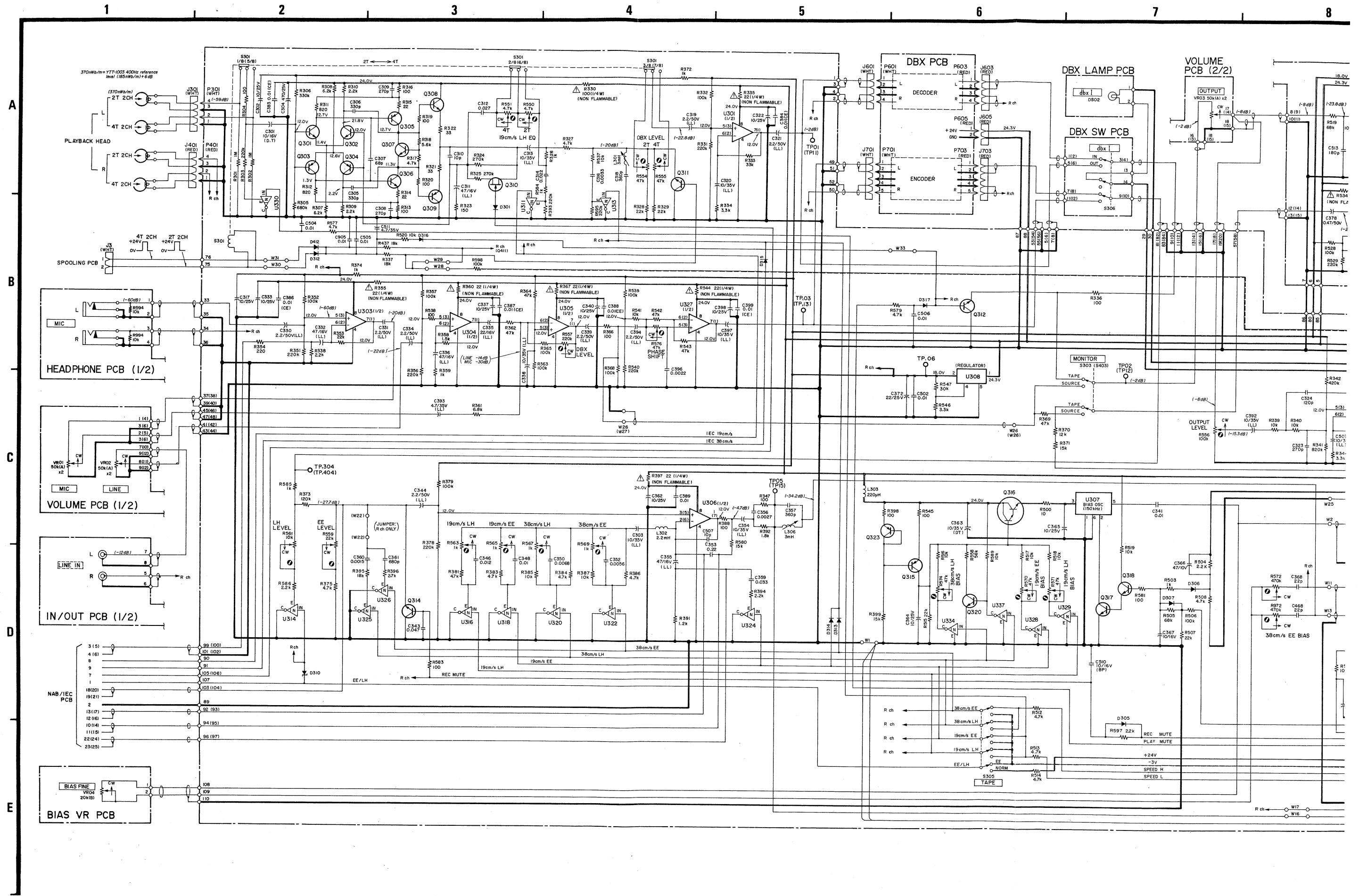

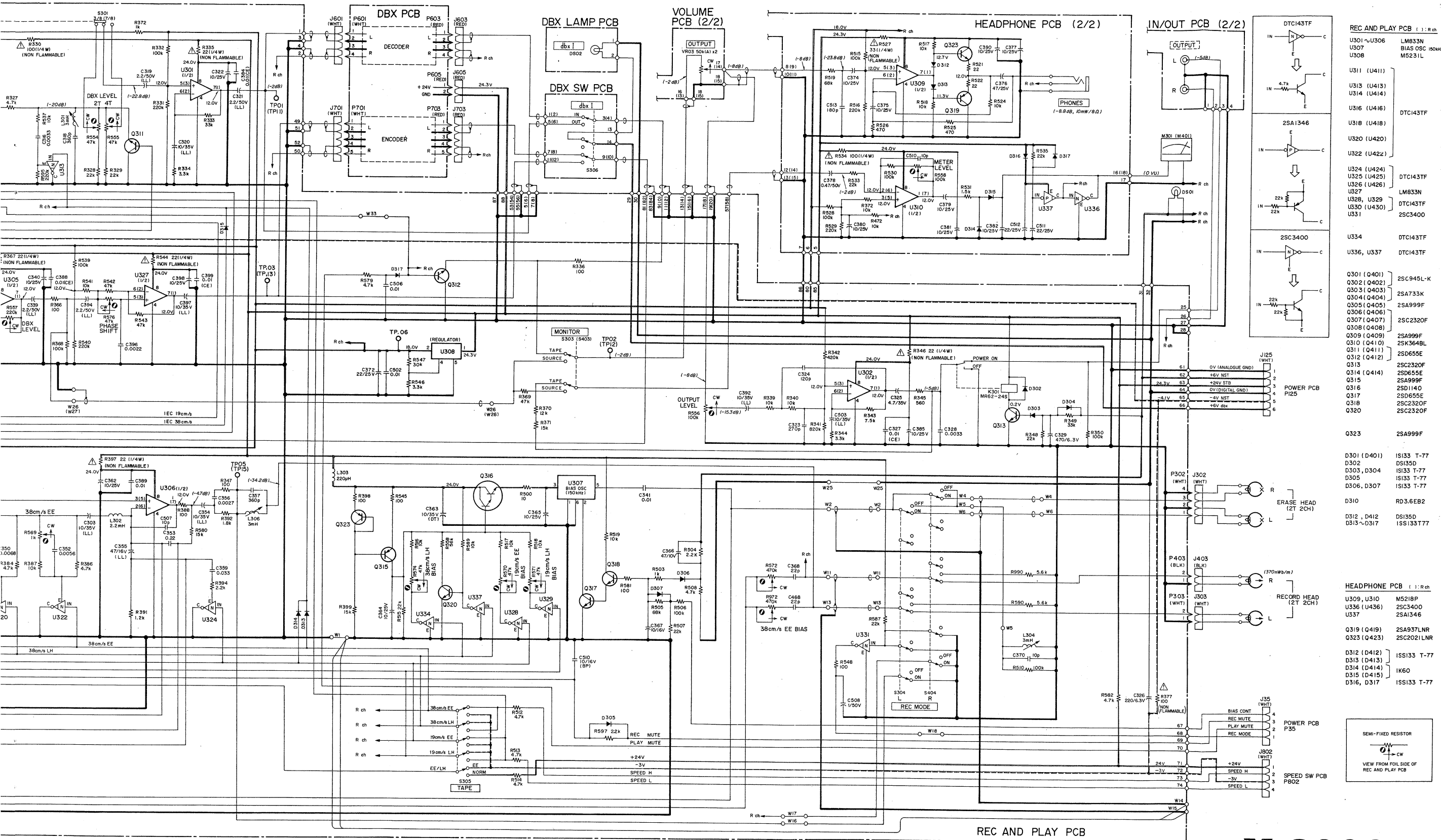

REC AND PLAY PCB (1: R ch)

- U301 ~ U306 LM833N
- U307 BIAS OSC 150kHz
- U308 M5231L
- U311 (U411)
- U313 (U413)
- U314 (U414)
- U316 (U416)
- U318 (U418)
- U320 (U420)
- U322 (U422)
- U324 (U424)
- U325 (U425)
- U326 (U426)
- U327 LM833N
- U328, U329 DTC143TF
- U330 (U430)
- U331 2SC3400

REC AND PLAY PCB (2: R ch)

- Q301 (Q401) 2SC945L-K
- Q302 (Q402)
- Q303 (Q403) 2SA733K
- Q304 (Q404)
- Q305 (Q405) 2SA999F
- Q306 (Q406)
- Q307 (Q407) 2SC2320F
- Q308 (Q408)
- Q309 (Q409) 2SA999F
- Q310 (Q410) 2SK364BL
- Q311 (Q411)
- Q312 (Q412) 2SD655E
- Q313 2SC2320F
- Q314 (Q414) 2SD655E
- Q315 2SA999F
- Q316 2SD1140
- Q317 2SD655E
- Q318 2SC2320F
- Q320 2SC2320F

REC AND PLAY PCB (3: R ch)

- D301 (D401) IS133 T-77
- D302 DS135D
- D303, D304 IS133 T-77
- D305 IS133 T-77
- D306, D307 IS133 T-77
- D310 RD3.6EB2
- D312, D412 DS135D
- D313 ~ D317 IS133T77

HEADPHONE PCB (1: R ch)

- U309, U310 M5218P
- U336 (U436) 2SC3400
- U337 2SA1346
- Q319 (Q419) 2SA937LNR
- Q323 (Q423) 2SC2021LNR
- D312 (D412) IS133 T-77
- D313 (D413)
- D314 (D414) IK60
- D315 (D415)
- D316, D317 IS133 T-77

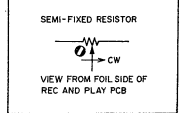

X-2000M

Stereo Tape Deck

2nd Issue; November, 1984

TEAC WIRING DIAGRAM X-2000M

1 2 3 4 5 6 7 8

A
B
C
D
E

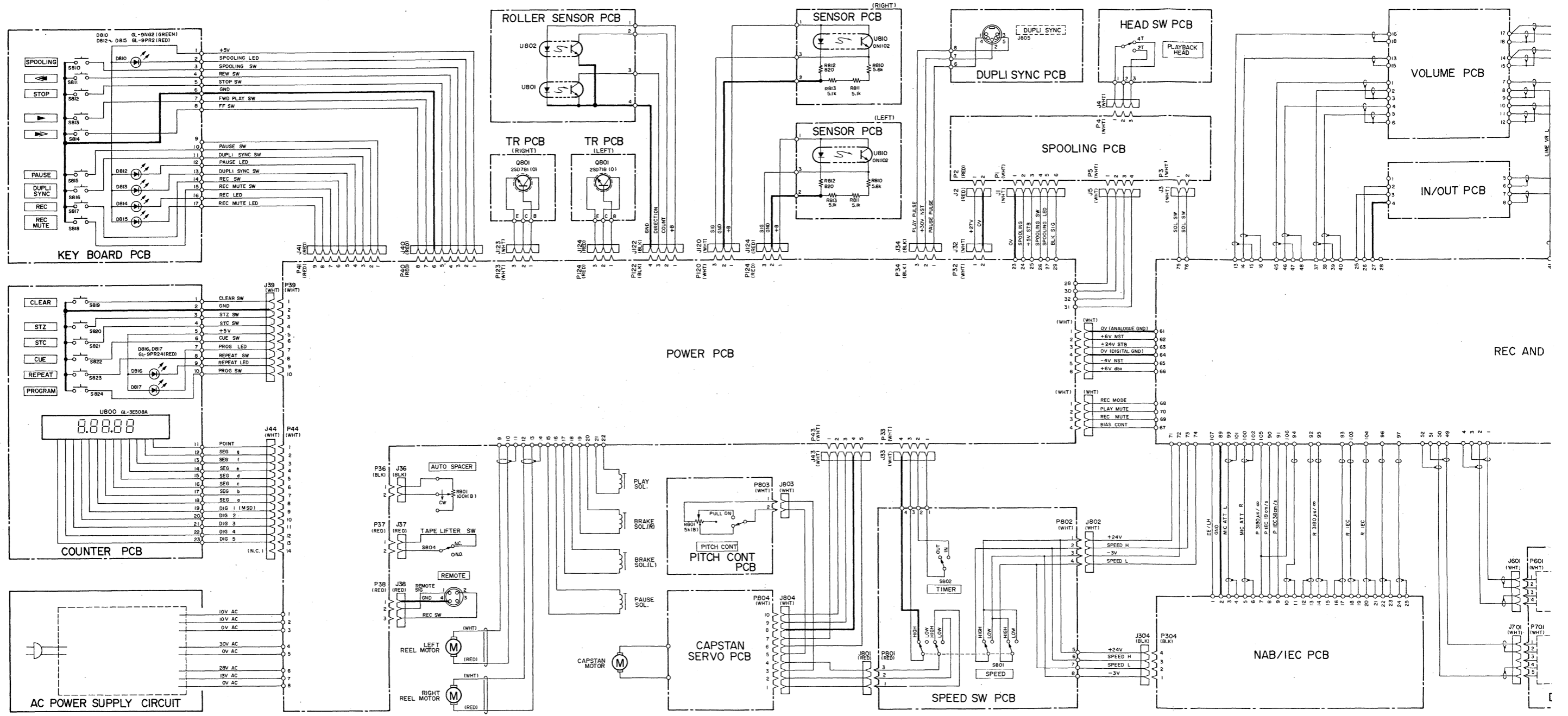

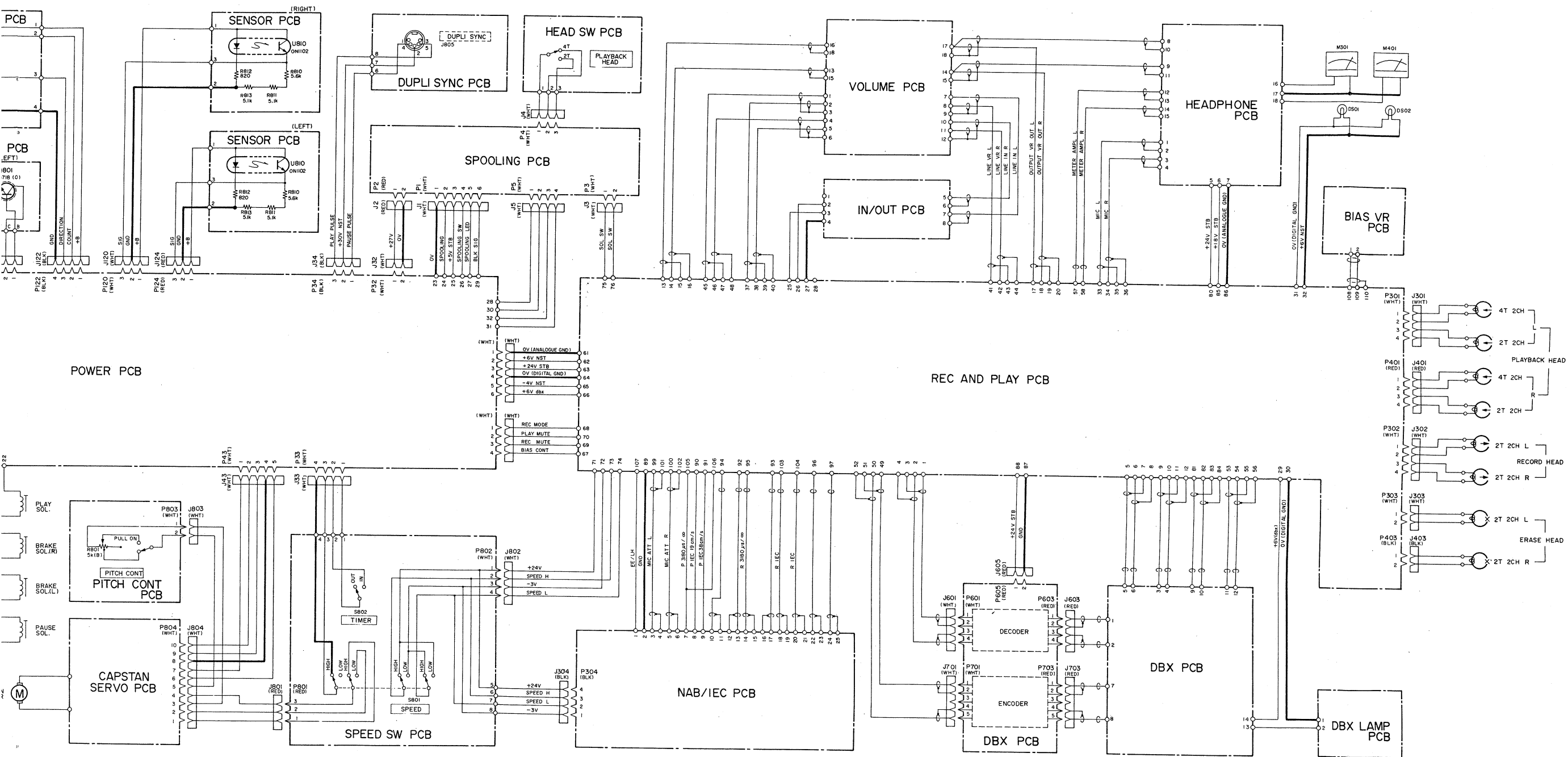

X-2000M
Stereo Tape Deck
 2nd Issue; November, 1984

TEAC SCHEMATIC DIAGRAM (REC/PLAY) X-2000

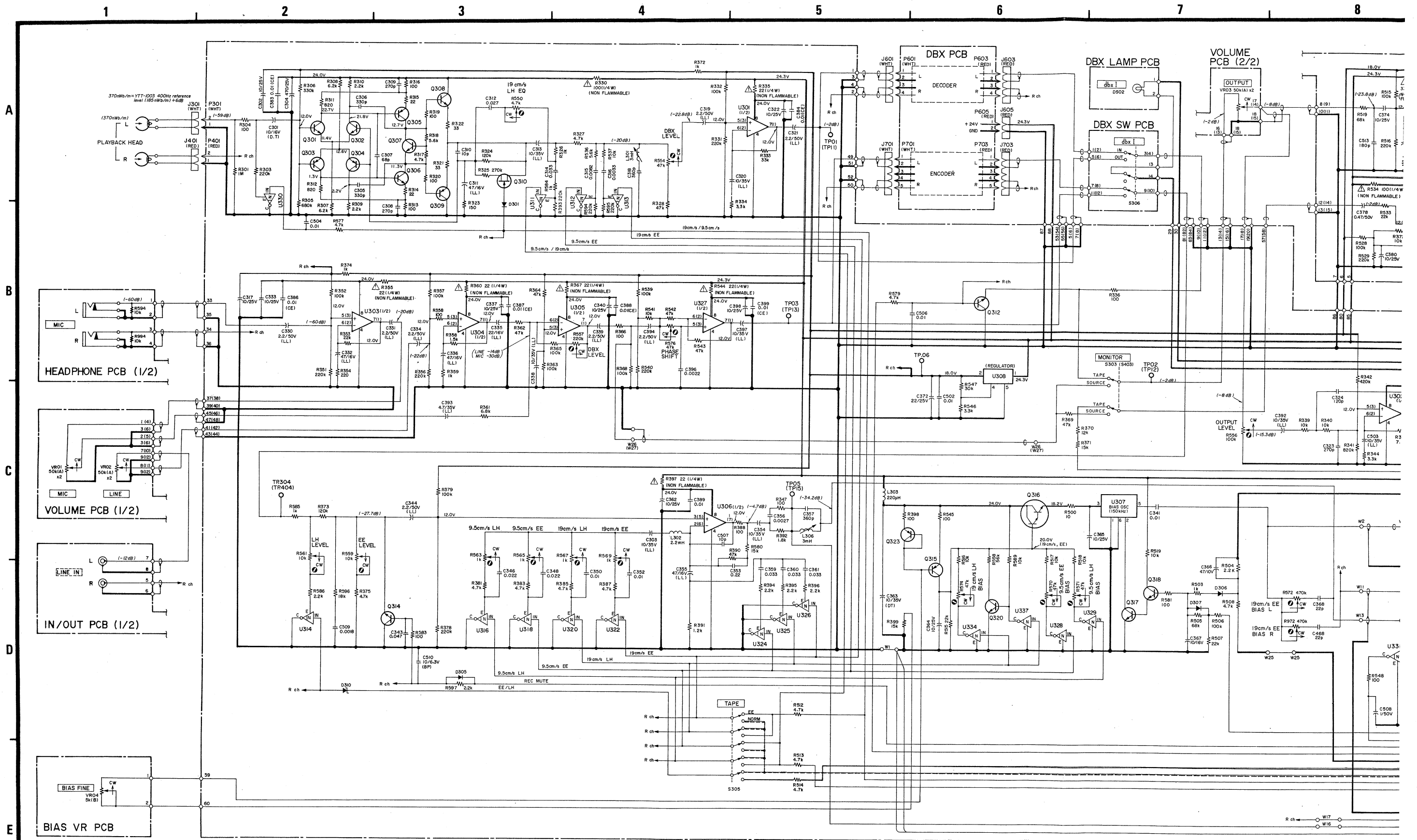

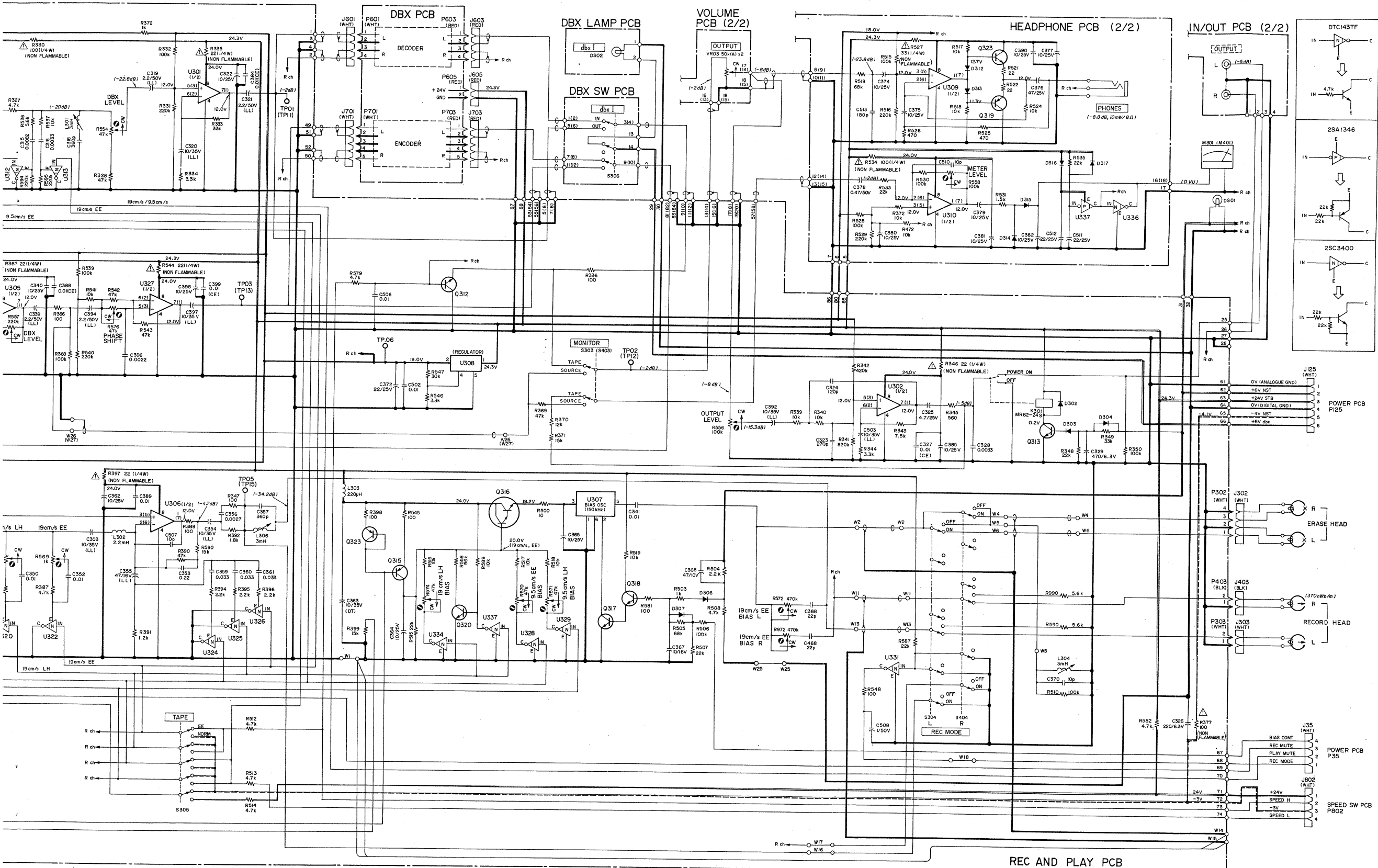

- REC AND PLAY PCB (1): R ch**
- U301 ~ U306 LM833N BIAS OSC 150kHz M5231L
 - U311 (U411)
 - U312 (U412)
 - U313 (U413)
 - U314 (U414)
 - U316 (U416) DTC143TF
 - U318 (U418)
 - U320 (U420)
 - U322 (U422)
 - U324 (U424) DTC143TF
 - U325 (U425)
 - U326 (U426) LM833N
 - U327
 - U328, U329 DTC143TF
 - U330 (U430) 25C3400
 - U331
 - U334 DTC143TF
 - U337 DTC143TF
- Q301 (Q401) 25C945L-K**
- Q302 (Q402) 25A733K**
- Q303 (Q403) 25A999F**
- Q304 (Q404) 25C2320F**
- Q305 (Q405) 25K364BL**
- Q306 (Q406) 25D655E**
- Q307 (Q407) 25D655E**
- Q308 (Q408) 25D655E**
- Q309 (Q409) 25D655E**
- Q310 (Q410) 25D655E**
- Q312 (Q412) 25D655E**
- Q313 25C2320F**
- Q314 (Q414) 25D655E**
- Q315 25A999F**
- Q316 25D1140**
- Q317 25D655E**
- Q318 25C2320F**
- Q320 25C2320F**
- Q323 25A999F**
- D301 (D401) IS133 T-77**
- D302 DS1350**
- D303, D304 IS133 T-77**
- D305 IS133 T-77**
- D306, D307 IS133 T-77**
- D308 DS1350**
- D310 RD3.6EB2**
- HEADPHONE PCB (1): R ch**
- U309, U310 M5218P
 - U336 (U436) 25C3400
 - U337 25A1346
- Q319 (Q419) 25A937LNR**
- Q323 (Q423) 25C2021LNR**
- D312 (D412) IS133 T-77**
- D313 (D413) IS133 T-77**
- D314 (D414) IK60**
- D315 (D415) IS133 T-77**
- D316, D317 IS133 T-77**

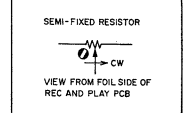

X-2000

Stereo Tape Deck

2nd Issue; November, 1984

TEAC WIRING DIAGRAM X-2000

1 2 3 4 5 6 7 8

A

B

C

D

E

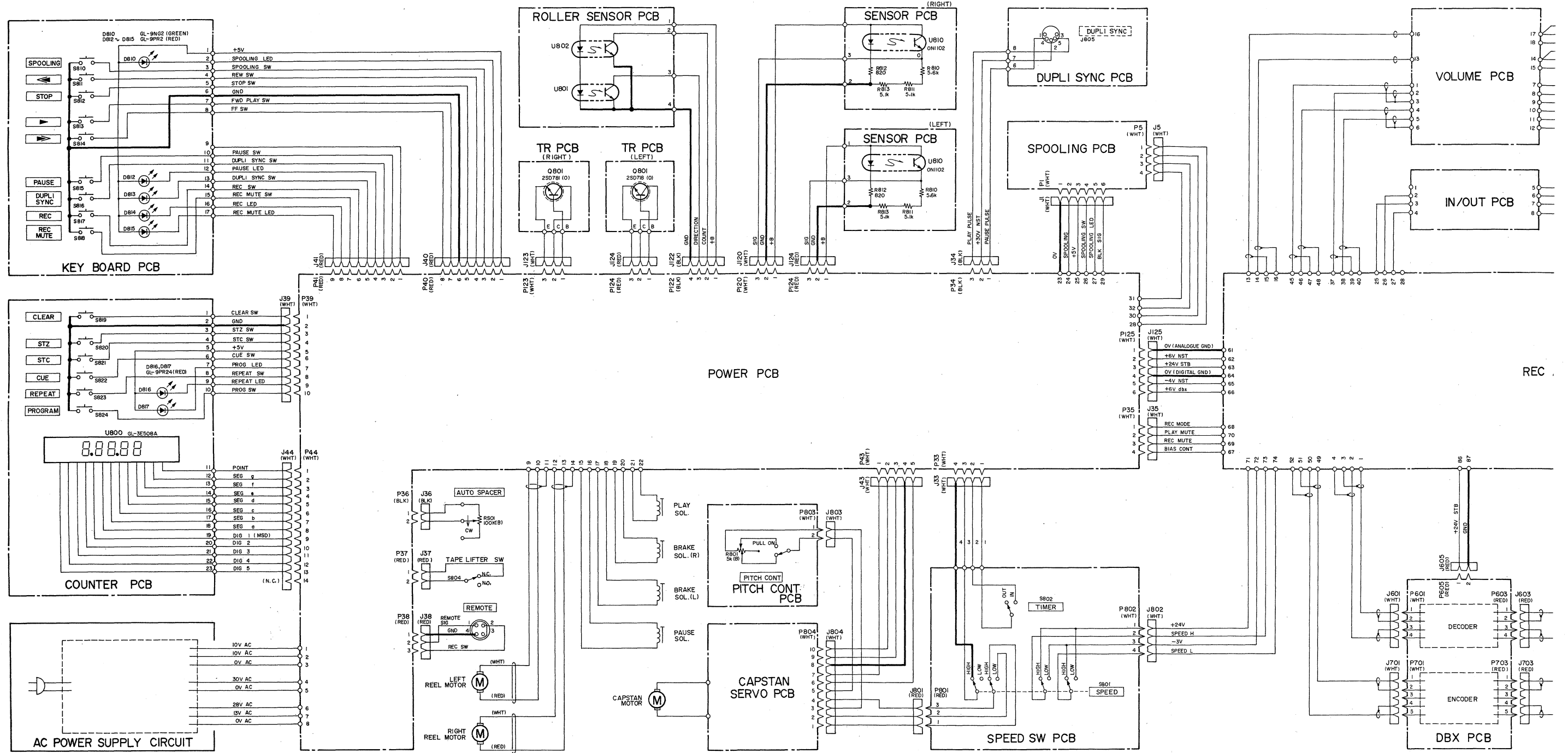

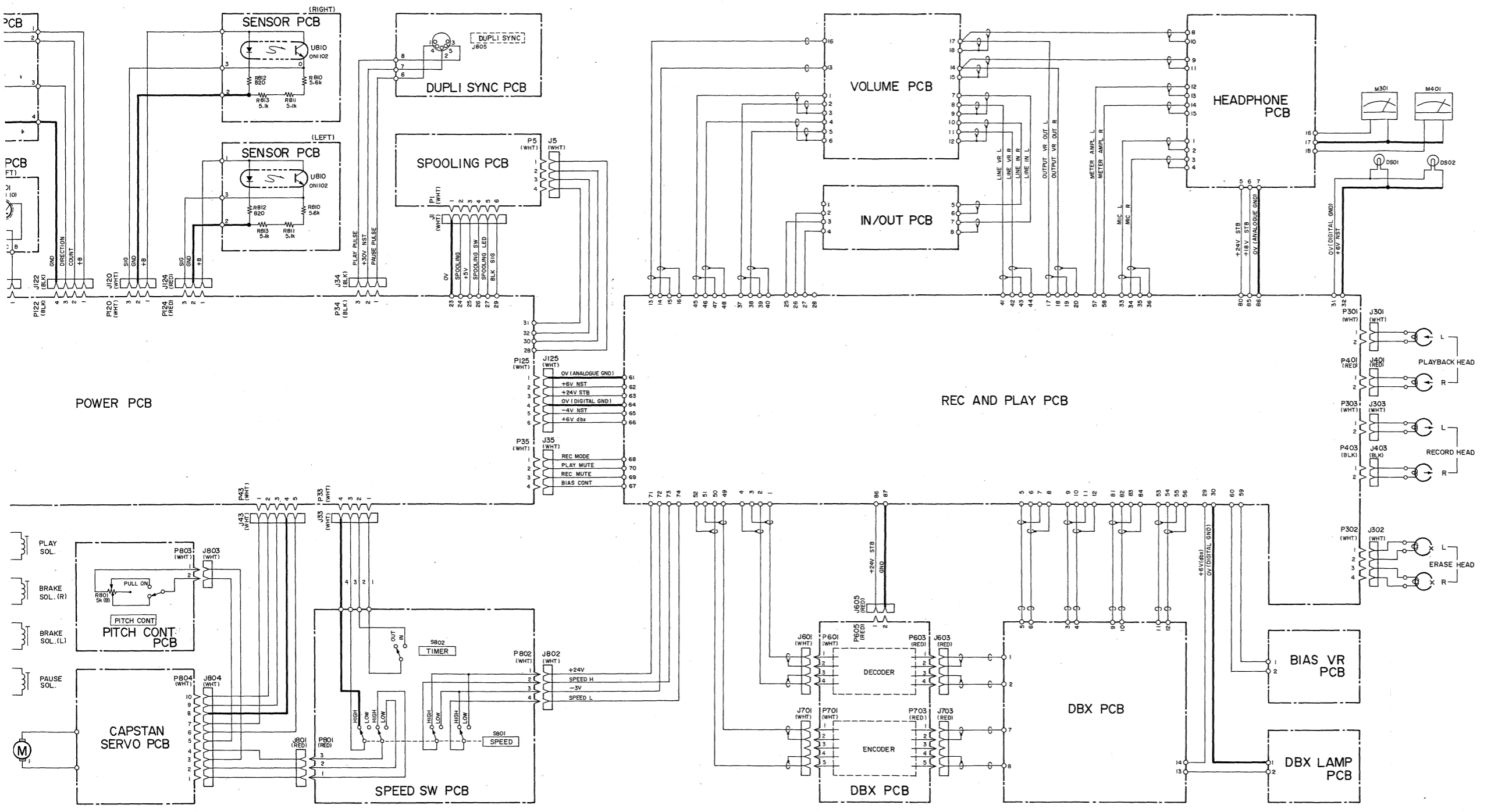

X-2000

Stereo Tape Deck

2nd Issue; November, 1984

TEAC SCHEMATIC DIAGRAM (POWER 1/2) X-2000M/X-2000

1 2 3 4 5 6 7 8

A

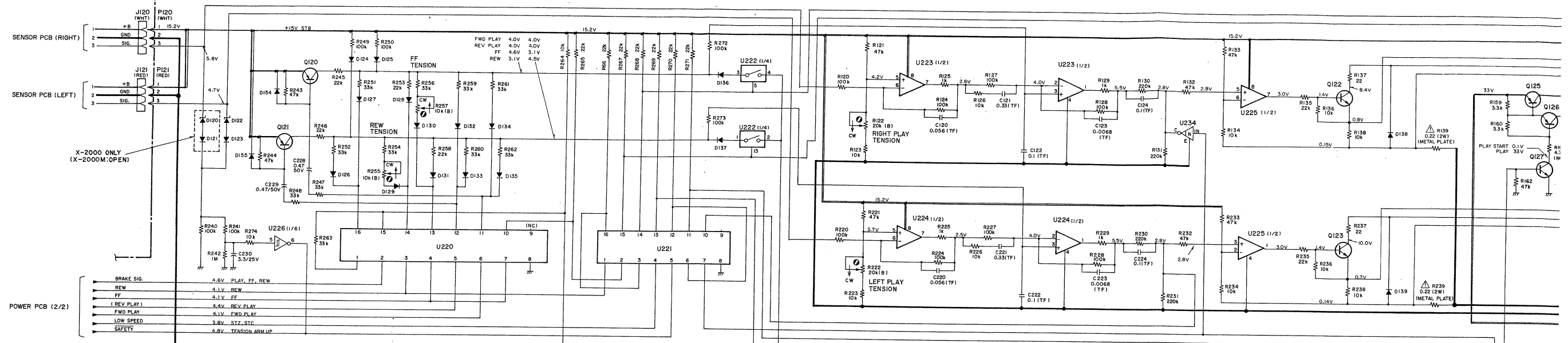

B

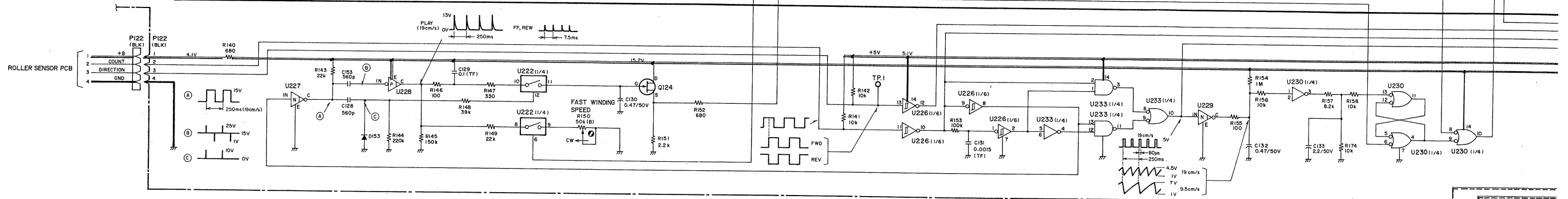

C

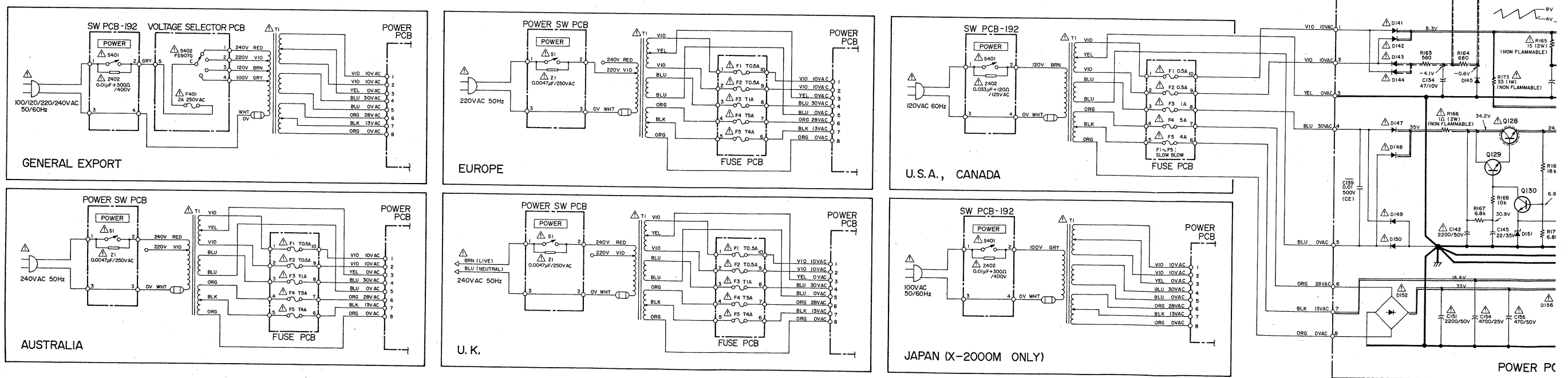

D

E

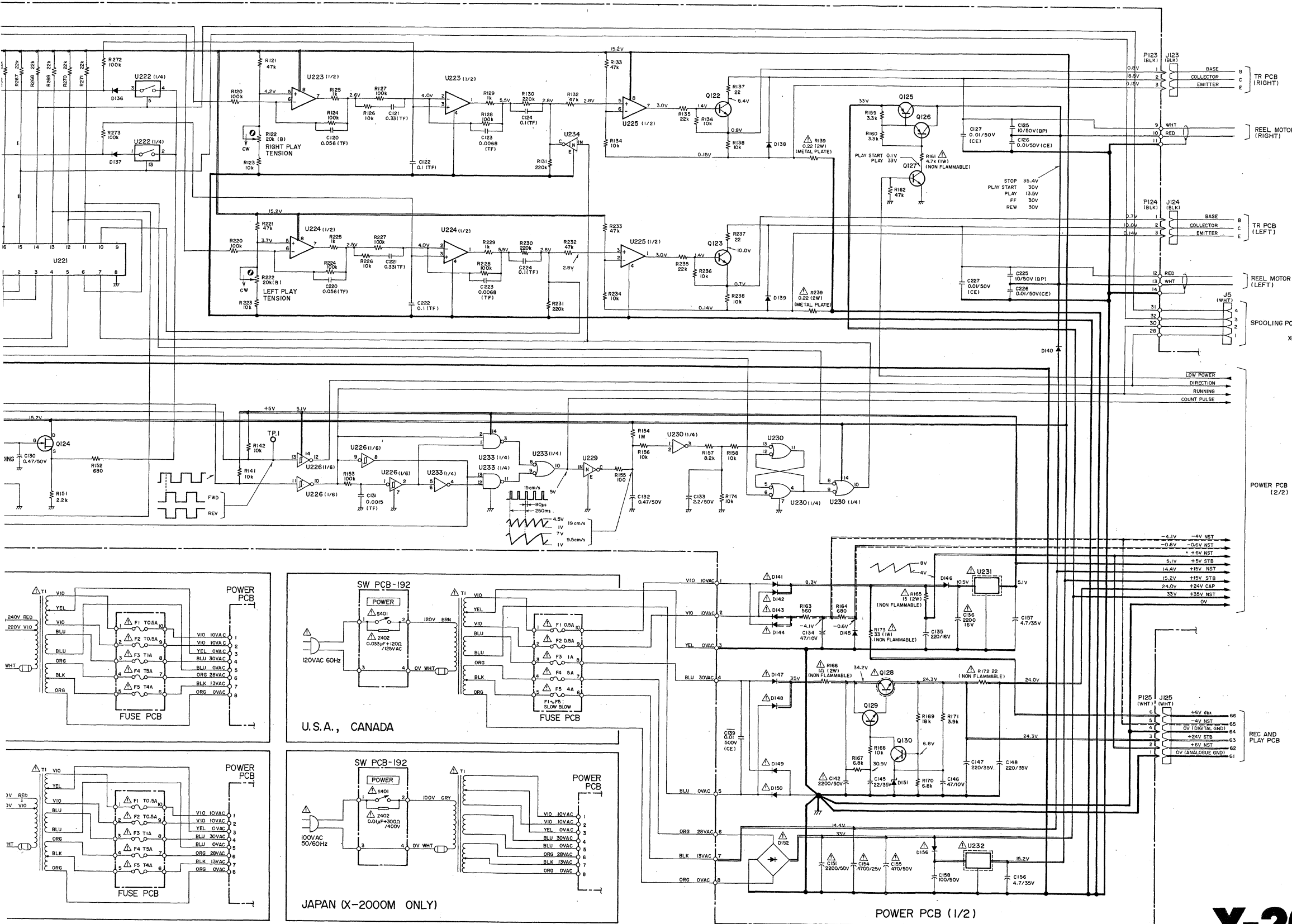

POWER PCB (1/2)

U220, U221	BA6251
U222	MCI4066B or HDI4066B
U223 ~ U225	LA6358
U226	MCI458BCP or HDI4584B
U227	2SC3400
U228	2SA1346
U229	2SC3400
U230	MCI4011BCP or HDI4011BP
U231	L78N05
U232	L78N15
U233	MCI4011BCP or HDI4011BP

Q120, Q121	2SA733P
Q122, Q123	2SC2320 (F)
Q124	2SK66 (A)
Q125	2SB507 (E)
Q126	2SA1015 (GR)
Q127	2SC945 (K)
Q128	2SD313E
Q129	2SC1318
Q130	2SC945 (K)

X-2000 ONLY

D120	RD9.1EB2
D121	ISSI33T
D122	RD9.1EB2
D123 ~ D137	ISSI33T
D138 ~ D144	DS1350
D145	ISSI33T
D146 ~ D150	DS1350
D151	RD6.2EB2
D152	M4C-5I
D153 ~ D155	DS1350
D156	DS1350

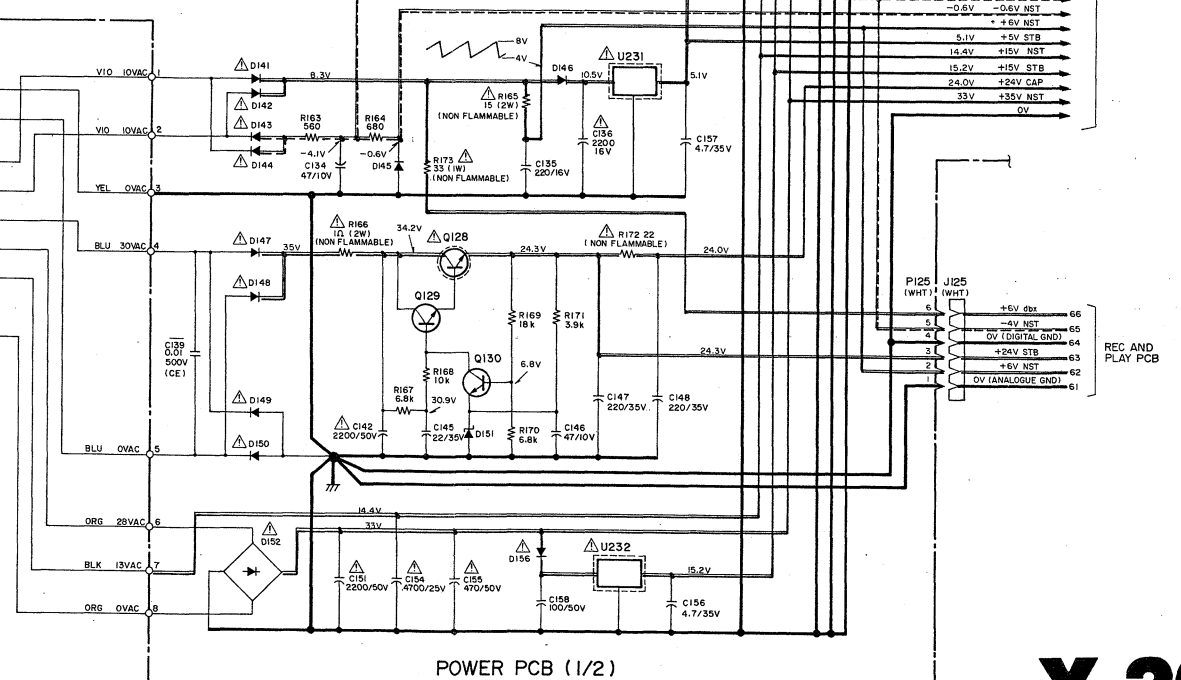
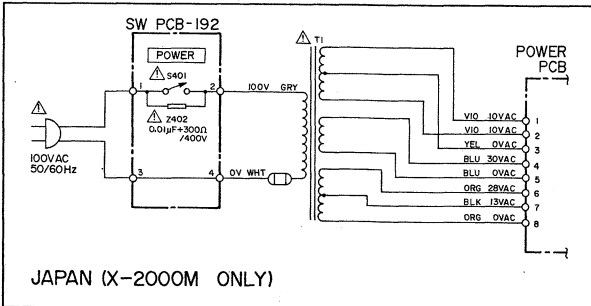
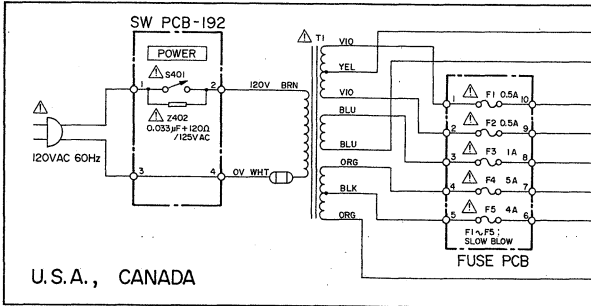
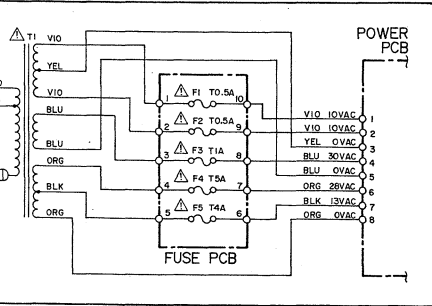
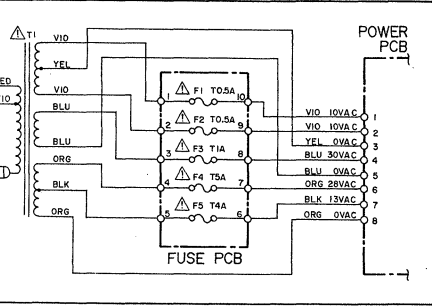
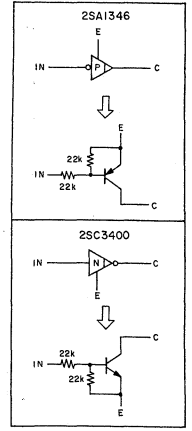

X-2000M/X-2000

Stereo Tape Deck

2nd Issue, November, 1984

TEAC SCHEMATIC DIAGRAM (POWER 2/2) X-2000M/X-2000

1 2 3 4 5 6 7 8

A
B
C
D
E

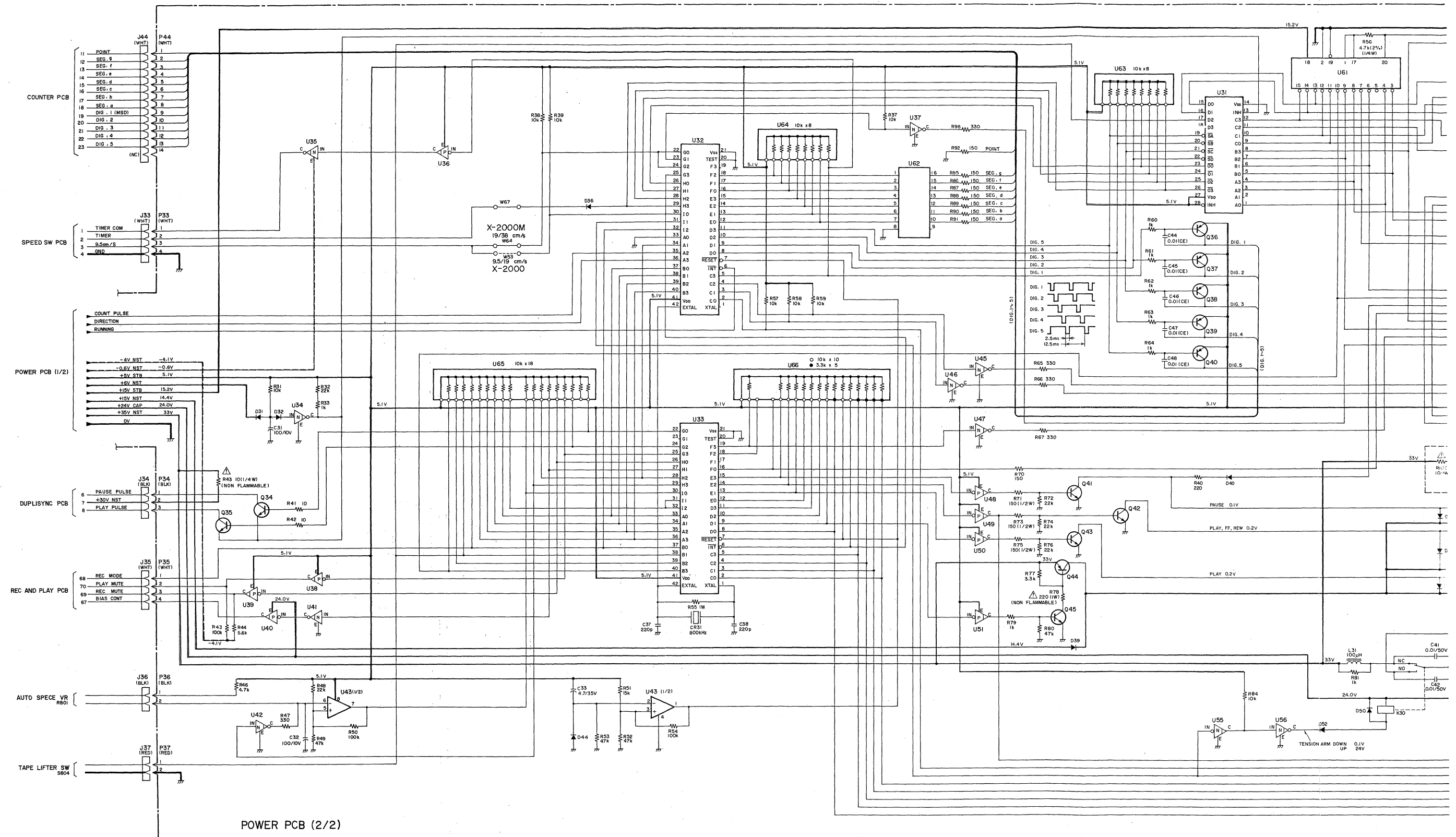

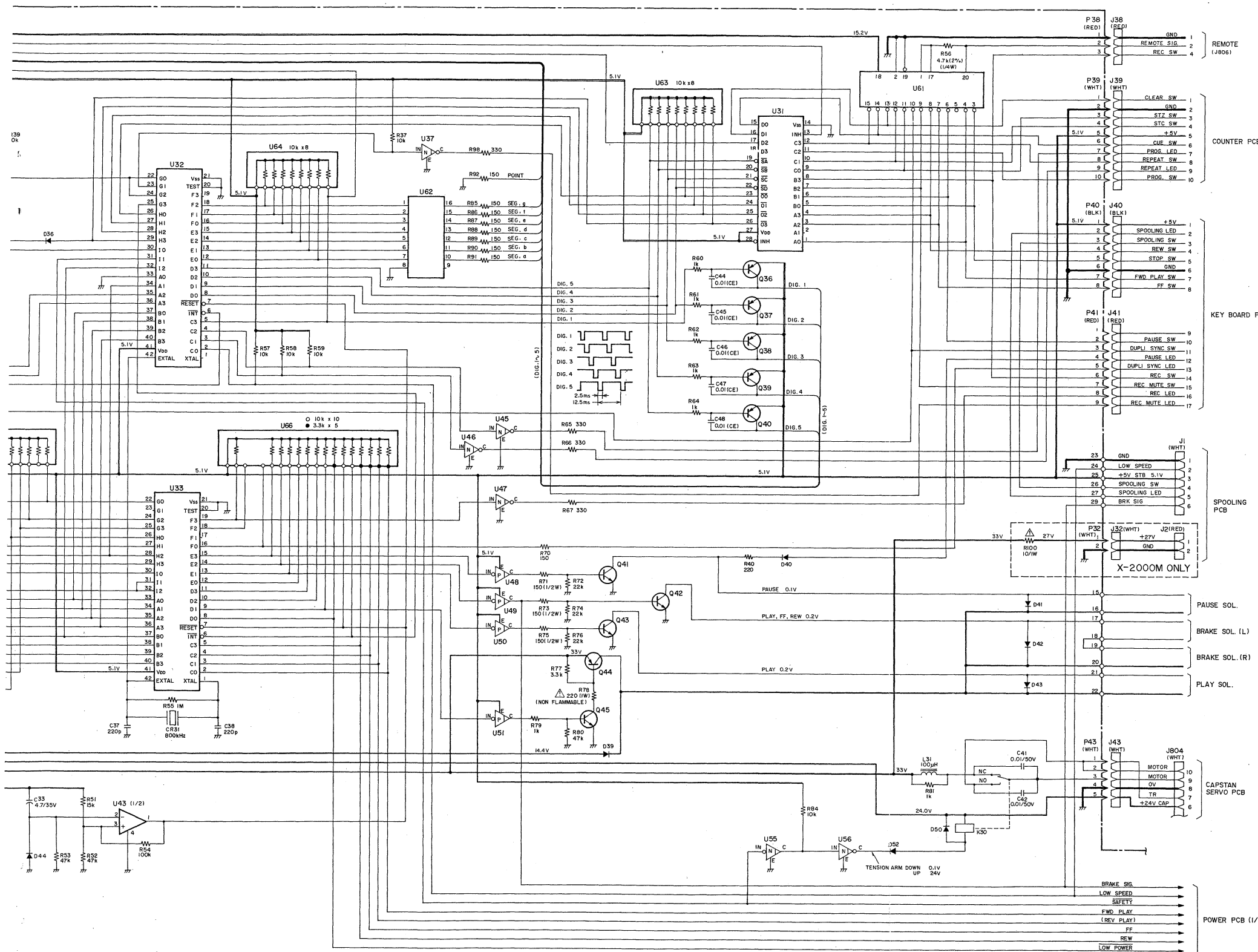

POWER PCB (I/2)

U31	LC7800
U32	LM6402H-325
U33	LM6405H-320
U34, U35	2SC3400
U36	2SA1346
U37	2SC3400
U38 ~ U40	2SA1346
U41, U42	2SC3400
U43	LA6358
U45 ~ U47	2SC3400
U48 ~ U51	2SA1346
U55, U56	2SC3400

U61	LB1475
U62	BA6251
U63 ~ U66	Resistor array

Q34, Q35	2SC945 (K)
Q36 ~ Q40	2SA733P-PB
Q41 ~ Q43	2SD794D
Q44	2SB507 (E)
Q45	2SC945 (K)

D31, D32	ISS133T
D36	ISS133T
D39	DSA26C
D40	ISS133T
D41 ~ D43	DS135D
D44	ISS133T

D50	DS135D
D52	ISS133T
D54	ISS133T

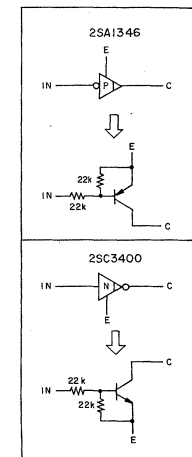

X-2000M/X-2000

Stereo Tape Deck

2nd Issue; November, 1984