

## INTRODUCTION

Thank you for your purchase of the HE18 Buzz Off. If you've got hum or buzz in your audio signal, the HE18 is the solution you need. Almost all AC hum is caused by ground loops. These ground loops act like radio antennae, picking up hum and noise. The HE18 removes many causes of noise by eliminating the ground potential.

## INSPECTION

1. Unpack and Inspect the HE18 package  
Your HE18 was carefully packed at the factory in a protective carton. Nonetheless, be sure to examine the unit and the carton for any signs of damage that may have occurred during shipping. If obvious physical damage is noticed, contact the carrier immediately to make a damage claim. We suggest saving the shipping carton and packing materials for safely transporting the unit in the future.

## WARRANTY

For information on the Rolls One Year Limited Warranty, and to register this product, visit our website at [www.rolls.com](http://www.rolls.com)

## DESCRIPTION

INPUT(S): 2 ea; 1/4" Tip-Ring-Sleeve jacks  
2 ea; RCA jacks

OUTPUT(S): 2 ea; 1/4" Tip-Ring-Sleeve jacks  
2 ea; RCA jacks

## OPERATION

To insert the HE18 in a system with a buzz or hum, disconnect the device you suspect is causing the noise. Connect that device's Output to either of the Inputs (1/4" or RCA), and connect the HE18 Output(s) to the next device in the signal chain.

For example; if you've got a buzz in your video system, connect the HE18 between the video unit and amplifier to isolate the signals.

**PLEASE NOTE: THE HE18 IS INTENDED TO RECEIVE LINE LEVEL (0db to +4 dB) SIGNALS. DO NOT CONNECT A MICROPHONE LEVEL SIGNAL OR A SPEAKER (POWERED) LEVEL SIGNAL TO THIS UNIT.**

**CONNECTING A SPEAKER LEVEL SIGNAL (ie. THE OUTPUT OF A POWER AMPLIFIER) WILL CAUSE PERMANENT DAMAGE TO THE HE18.**

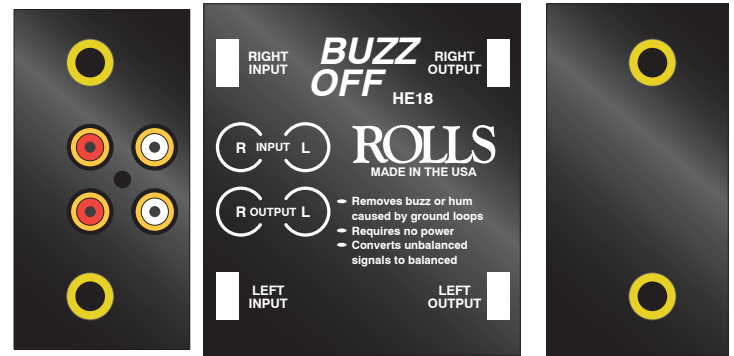

## DIAGRAM

Max Out:	Bal: +18 dB Unbal: +12 dB
Max In:	Bal: +22 dB Unbal: +22 dB
Input Impedance:	RCA: 10 k Ohm 1/4": 10 k Ohm balanced
Output Impedance:	RCA: 10 k Ohm 1/4": 10 k Ohm balanced
THD:	.05% @ 1 kHz
Weight:	1 lbs. (.45 Kg)
Size:	4.15" x 2.46" x 1.55"

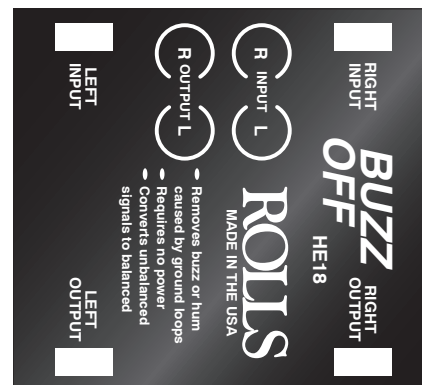

**ROLLS**  
**HE18**  
**BUZZ OFF**

## SCHEMATIC

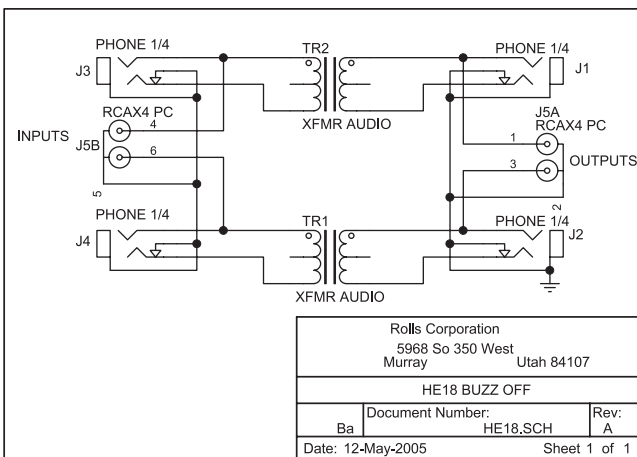

**HE18 Buzz Off**  
The HE18 helps remove hum and buzz from a balanced or unbalanced line. Perfect for musicians or audio professionals, the unit is safe and convenient to operate. Simply connect the offending line into the input, and connect the output to your next device.

- Helps eliminate ground hum and buzz
- Dual channel
- No power required - completely passive
- Converts balanced to unbalanced lines and vice versa